



Schemi per interventi di soccorso autovetture

Edizione 01 / 2014



Mercedes-Benz

Prefazione

Gentile Lettore,

garantire la massima sicurezza è tradizionalmente uno dei principali obiettivi perseguiti da Mercedes-Benz.

Di una dettagliata strategia di sicurezza fanno parte anche le informazioni mirate sui nostri veicoli e sui loro sistemi di sicurezza che mettiamo a disposizione delle squadre di soccorso.

Obiettivo primario delle squadre di soccorso è salvare vite umane. I soccorritori devono pertanto poter accedere il più rapidamente possibile ai feriti, senza esporre questi ultimi o se stessi a ulteriori pericoli.

Indispensabile è a tal proposito una solida formazione delle squadre di soccorso. Sono inoltre fondamentali conoscenze sulle possibilità di accesso specifiche di ogni veicolo e sui principi di funzionamento ed azione dei sistemi di sicurezza.

Oltre alla „Guida per i servizi di soccorso“, Mercedes-Benz con gli „Schemi per interventi di soccorso“ mette a disposizione, in forma compressa, informazioni per molte serie e molti modelli prodotti a partire dal 1971 (camper a partire dal 1995).

I proprietari di veicoli e le squadre di soccorso possono scaricare gli Schemi per interventi di soccorso gratuitamente in Internet.

Gli Schemi per interventi di soccorso dispongono di un layout a colori. Tale accorgimento facilita il rilevamento rapido dei contenuti essenziali. Consigliamo pertanto vivamente di optare per la stampa a colori.

i Avvertenza:

Negli Schemi per interventi di soccorso sono contrassegnati come rinforzi della carrozzeria quei settori la cui tranciatura per mezzo di attrezzature standard risulterà notevolmente più difficile per le squadre di soccorso.

Le indicazioni relative alla presenza di rinforzi della carrozzeria si limitano pertanto alle aree in corrispondenza delle quali potrebbe essere necessario effettuare tagli per il salvataggio di persone e la cui conoscenza da parte del coordinatore dei soccorsi risulta quindi opportuna.

Come protezione anticapottamento sono contrassegnati solo dispositivi mobili (roll-bar ribaltabili o estraibili).

© 2014 by Daimler AG

L'opera, comprese tutte le sue parti, è protetta dal copyright. Qualsiasi impiego o utilizzo commerciale richiede la previa autorizzazione scritta di Daimler AG, reparto GSP/OR, D-70546 Stuttgart.

Ciò vale in particolare per la riproduzione, diffusione, modifica, traduzione, registrazione su microfilm e la memorizzazione e/o elaborazione in sistemi elettronici, compresi le banche dati ed i servizi online

Come trovare lo Schema per interventi di soccorso giusto?

Tipi e modelli

Lo Schema per interventi di soccorso è valido sempre per una serie.

Le varianti di modello di una serie (ad es. motore a benzina o diesel) sono riconoscibili sullo Schema per interventi di soccorso tramite i corrispondenti numeri di posizione nella figura e le relative legende.

Sistemi di protezione dei passeggeri

Dalla denominazione del tipo o del modello di un veicolo non è possibile sapere quali e quanti airbag, generatori di gas, pretensionatori, ecc. sono presenti nel veicolo.

La rappresentazione dei sistemi di protezione dei passeggeri si orienta pertanto alla dotazione massima. Alle squadre di soccorso viene così fornita una panoramica che mostra dove possono essere montati sistemi di protezione dei passeggeri nel veicolo.

Determinazione del tipo di veicolo sulla base del n. di ident. veicolo (FIN)

Targhetta del tipo sul veicolo:

Consultare le istruzioni d'uso per conoscere la posizione in cui nel proprio veicolo è montata la targhetta del tipo.

Esempio n. di ident. veicolo (cfr. figura in basso)
WDD2120xx1Axxxxxx

Nel presente caso si tratta di un veicolo del tipo 212, lo 0 identifica il veicolo come berlina.

Inoltre è possibile identificare il proprio veicolo sulla base dell'anno di costruzione e delle raffigurazioni di veicolo sullo Schema per interventi di soccorso.

Lo Schema per interventi di soccorso giusto si trova quindi alla voce

Classe E berlina - Tipo 212



Targhetta del tipo, esempio Classe E berlina, tipo 212

- A Le prime 3 lettere o cifre rappresentano il codice internazionale del costruttore
- B Le cifre da 4 a 6 indicano il tipo di veicolo
- C La cifra 7 sta per la forma di carrozzeria

Forme di carrozzeria:

- 0 Berlina
- 1 Berlina lunga
- 2 Station-wagon (transporter)
- 3 Coupé
- 4 Cabriolet/roadster
- 9 Edizioni speciali (ad es. GLK)



Mercedes-Benz

190 berlina
tipo 201
1982 - 1993

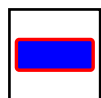
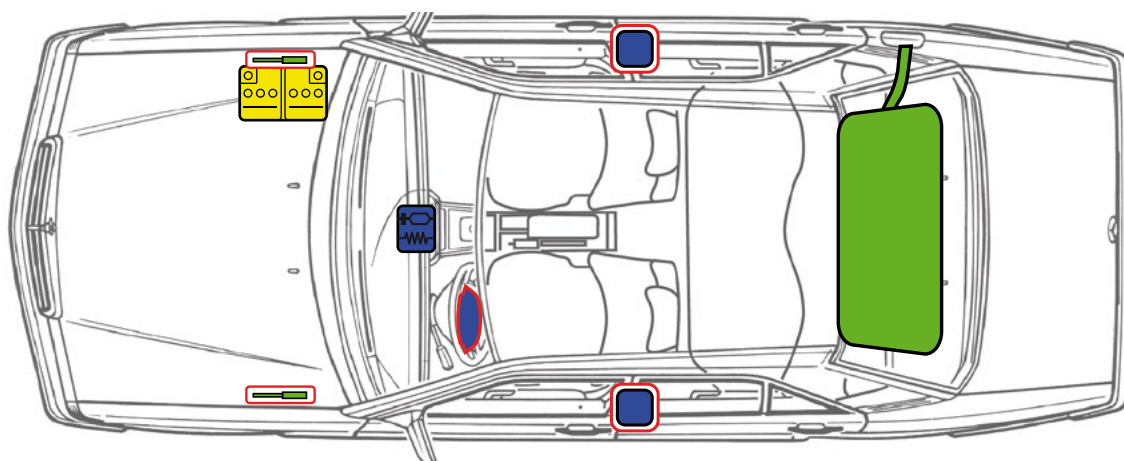
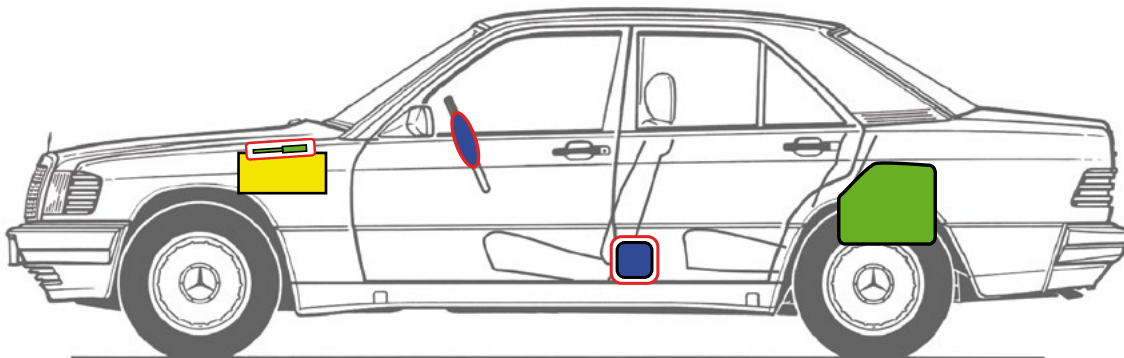

Airbag



Ammortizzatore
pneumatico



Centralina di comando
sistemi di ritenuta



Batteria

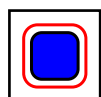

Pretensionatore



Serbatoio carburante



Mercedes-Benz

Classe A berlina
tipo 168
1997 - 2004

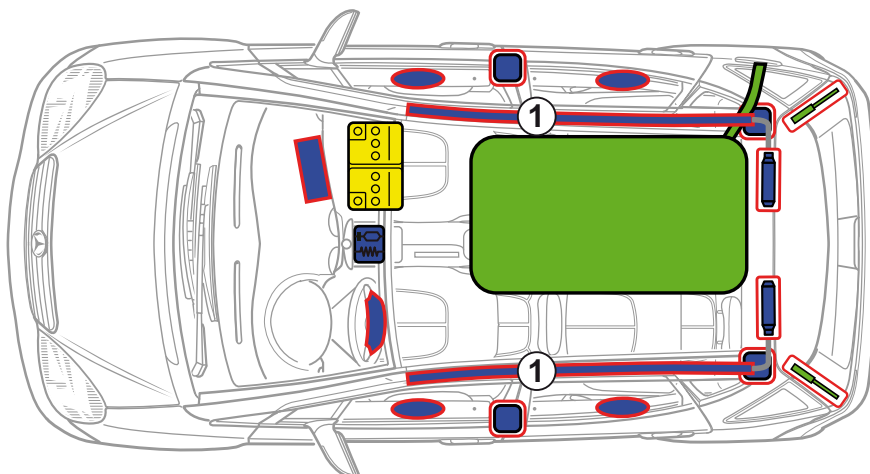
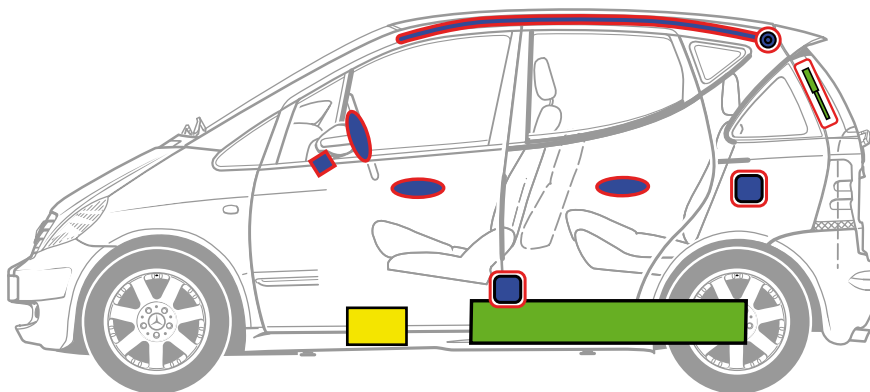

1 A partire da 2001

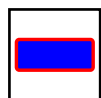

Airbag



Pretensionatore



Ammortizzatore
pneumatico



Batteria

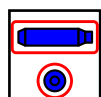

Generatore di gas



Centralina di comando
sistemi di ritenuta



Serbatoio carburante



Mercedes-Benz

Classe A berlina
tipo 169
2004 - 2012

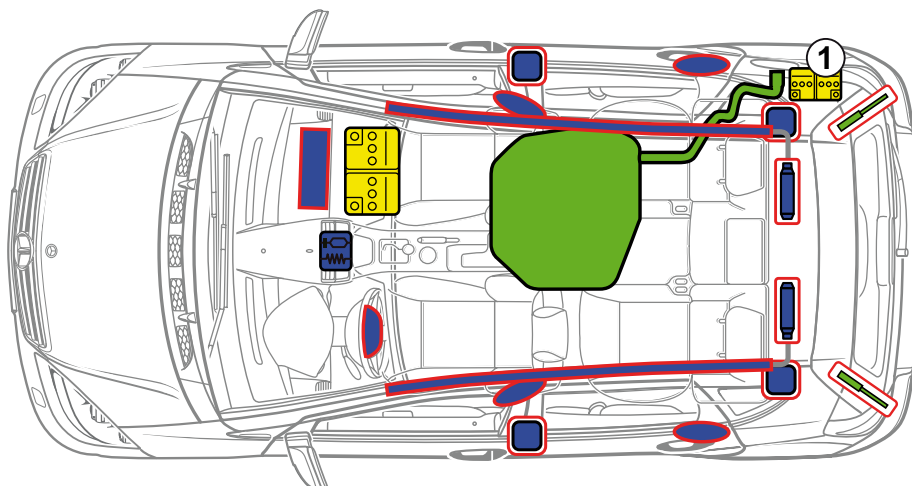
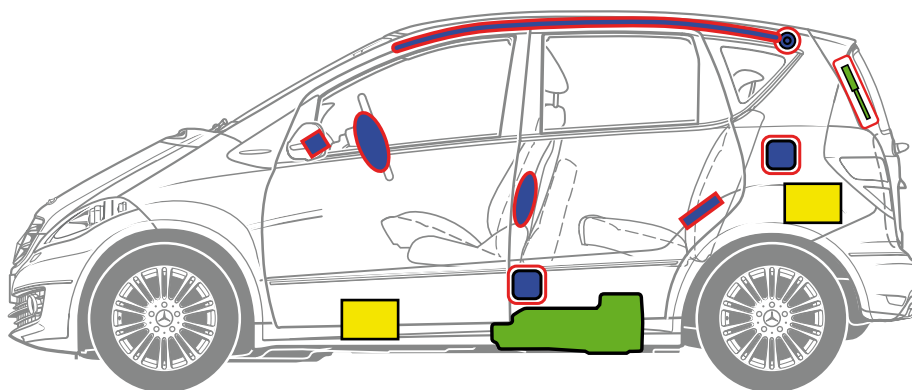

1 Batteria supplementare modelli BlueEFFICIENCY

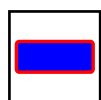

Airbag

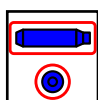

Generatore di gas

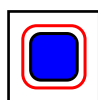

Pretensionatore

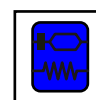

Centralina di comando sistemi di ritenuta

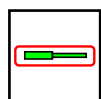

Ammortizzatore pneumatico



Serbatoio carburante



Batteria



Mercedes-Benz

Classe A E-CELL berlina tipo 169 a partire da 2010

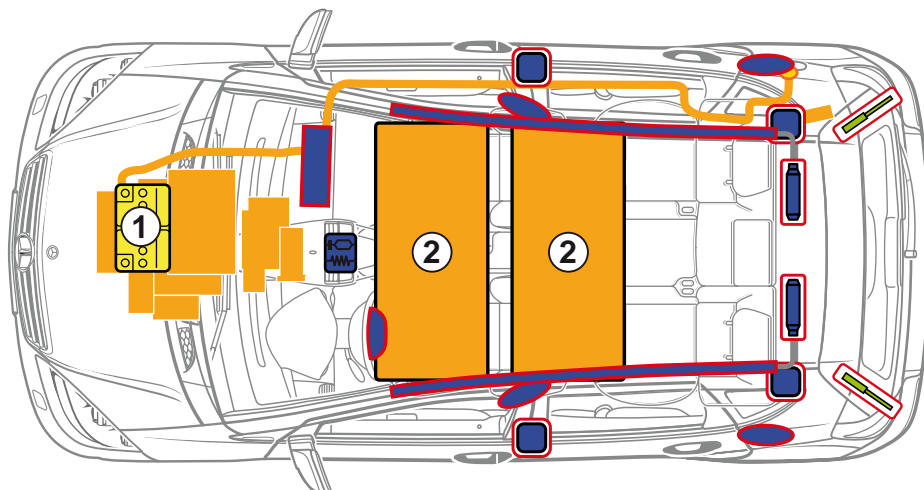
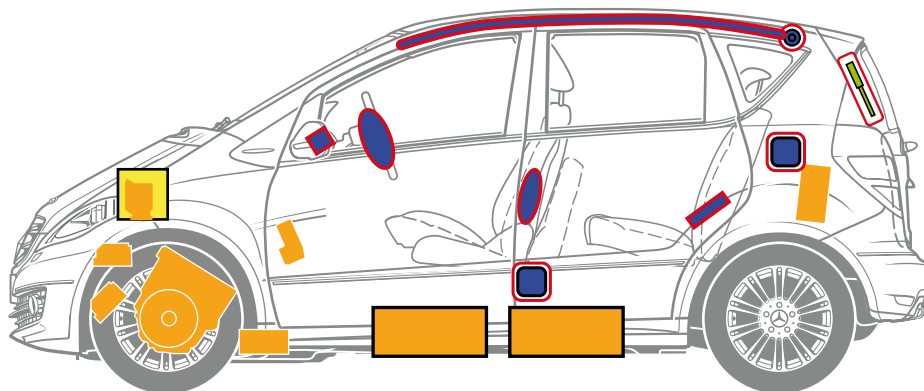

- 1 Batteria (12 V)
- 2 Batteria ad alto voltaggio



Airbag



Generatore di gas



Pretensionatore



Centralina di comando sistemi di ritenuta



Ammortizzatore pneumatico



Batteria 12 V



Batteria ad alto voltaggio



Componenti per l'alto voltaggio



Mercedes-Benz

Classe A E-CELL berlina
tipo 169
a partire da 2010



Identificazione veicolo



Presella di carica di alto voltaggio

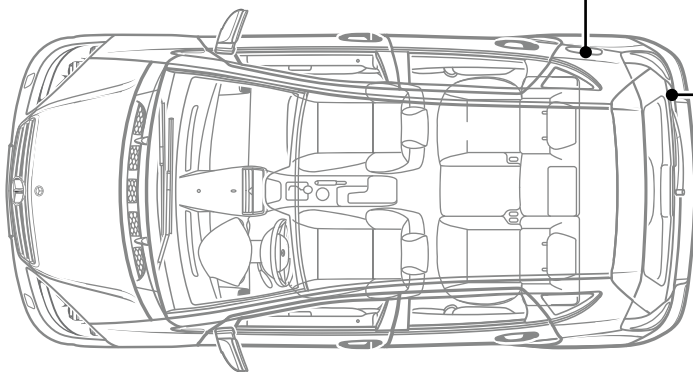

Portellone posteriore lato destro



Mercedes-Benz

Classe A berlina
tipo 176
a partire da 2013

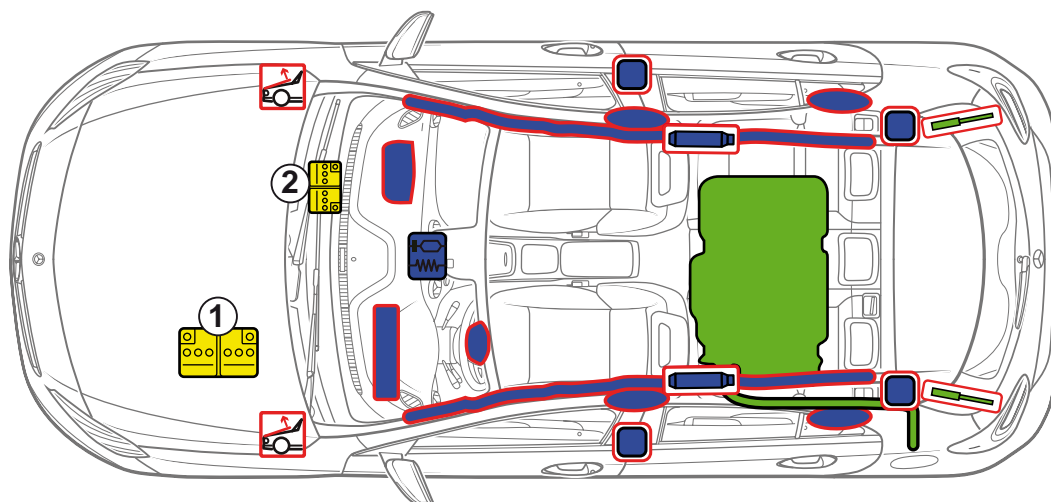
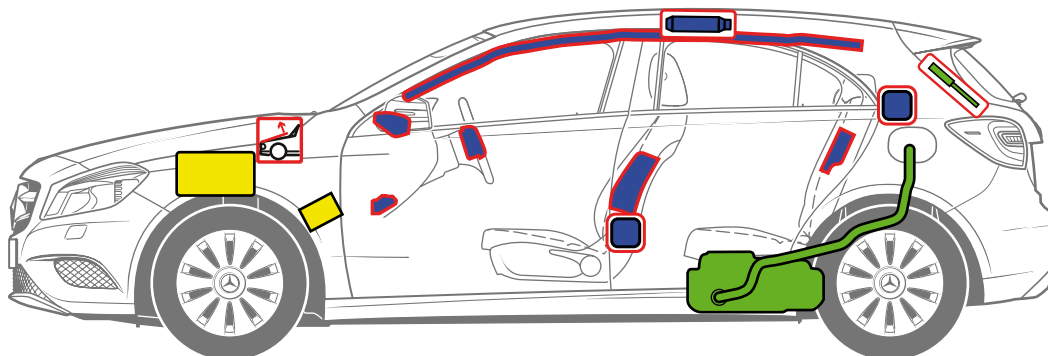

- 1 Batteria rete di bordo
- 2 Batteria supplementare ECO start/stop



Airbag



Generatore di gas



Pretensionatore



Centralina di comando sistemi di ritenuta



Ammortizzatore pneumatico



Serbatoio carburante



Protezione pedoni



Batteria



Mercedes-Benz

Classe C berlina
tipo 202
1993 - 2001

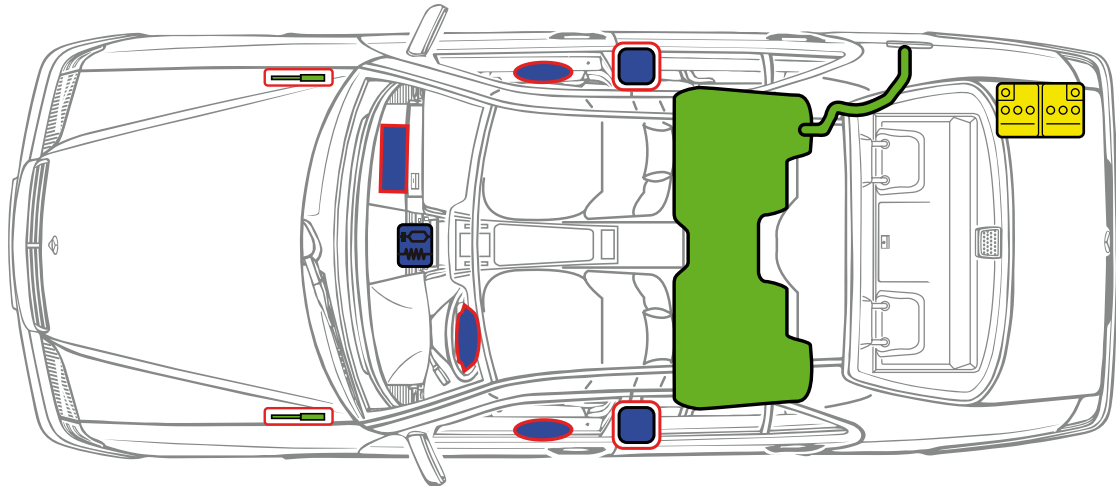
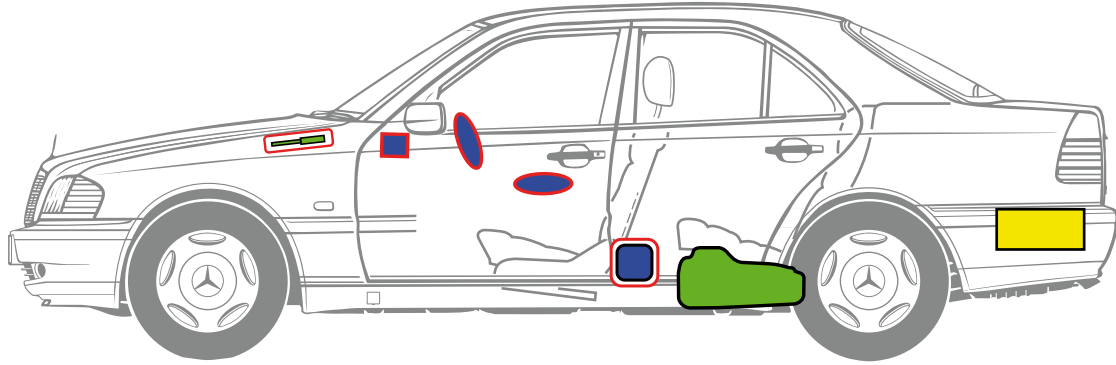

Airbag

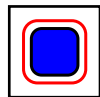

Pretensionatore



Centralina di comando
sistemi di ritenuta



Ammortizzatore
pneumatico



Serbatoio carburante

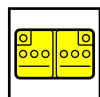

Batteria



Mercedes-Benz

Classe C berlina
tipo 203
2000 - 2007

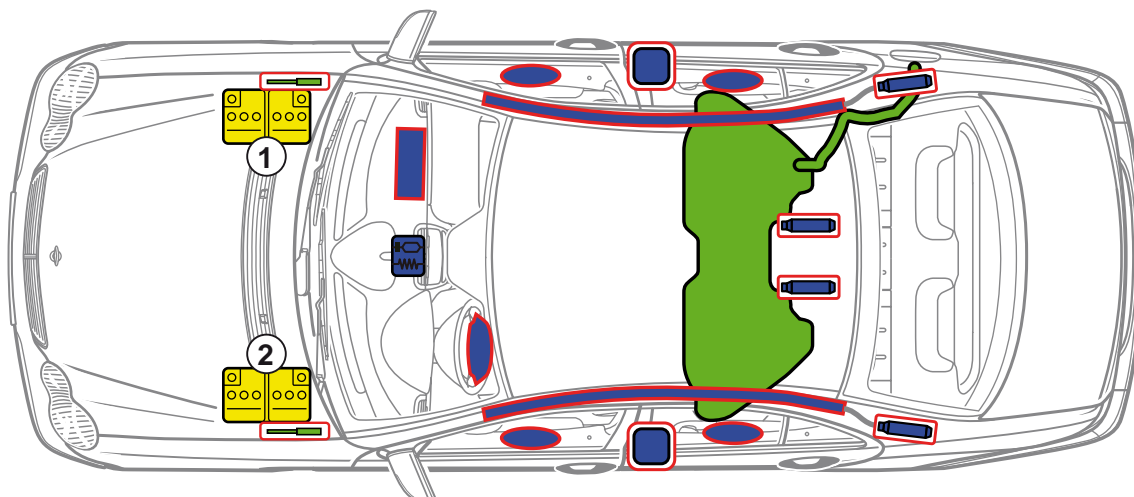
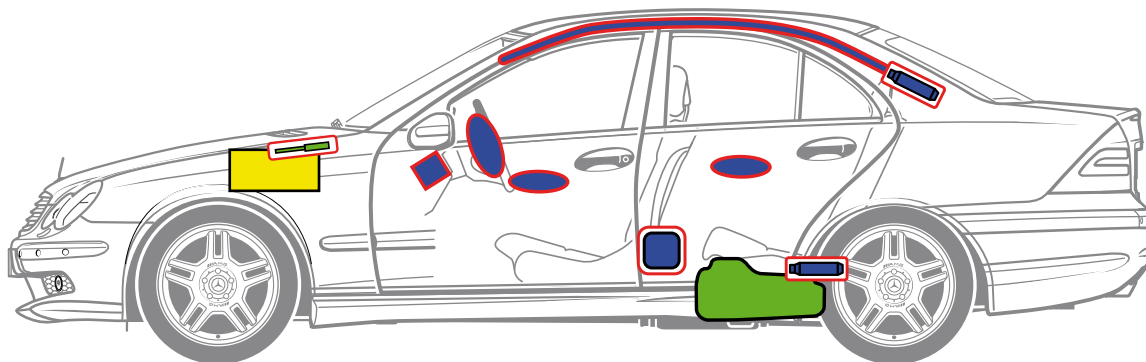
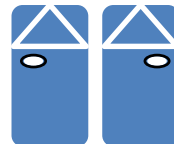

- 1 Veicolo con guida a sinistra
- 2 Veicolo con guida a destra



Airbag



Generatore di gas



Pretensionatore



Centralina di comando sistemi di ritenuta



Ammortizzatore pneumatico



Serbatoio carburante



Batteria



Mercedes-Benz

Classe C berlina
tipo 204
2007 - 2014

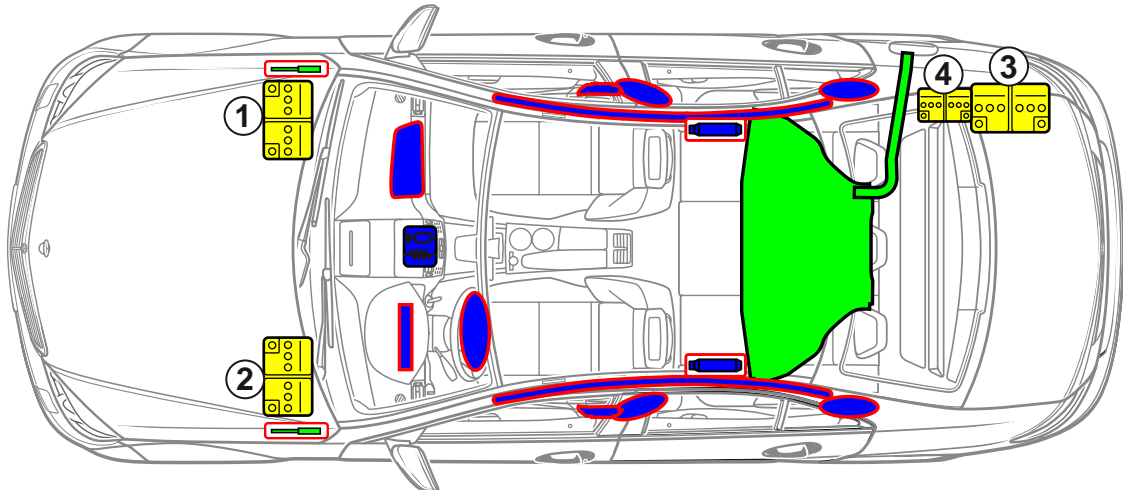
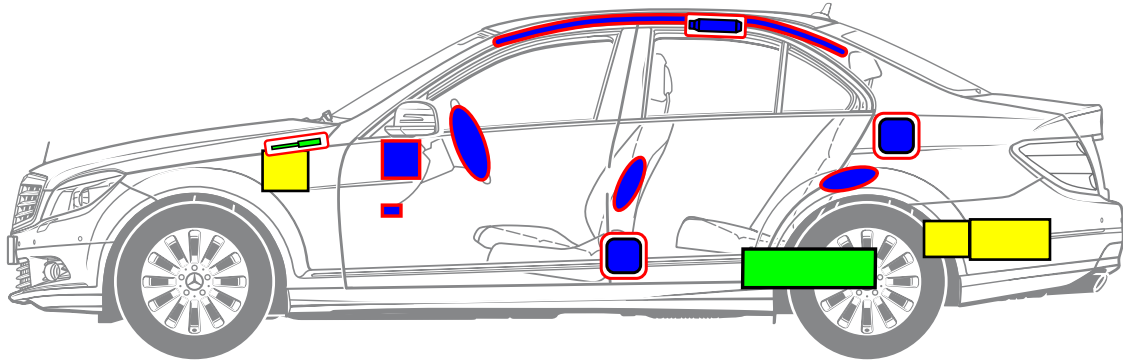
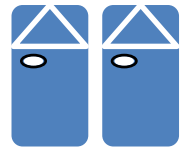

- 1 Batteria rete di bordo in caso di motore a benzina, a partire da 1.12.2009 in caso di motore diesel a 4 o 8 cilindri e AMG, veicolo con guida a sinistra
- 2 Batteria rete di bordo in caso di motore a benzina, a partire da 1.12.2009 in caso di motore diesel a 4 o 8 cilindri e AMG, veicolo con guida a destra
- 3 Batteria rete di bordo in caso di motore diesel a 6 cilindri, fino a 30.11.2009 in caso di motore diesel a 4 o 8 cilindri e AMG
- 4 Batteria supplementare ECO start/stop

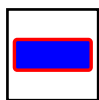

Airbag

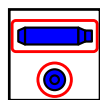

Generatore di gas

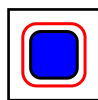

Pretensionatore

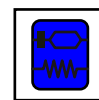

Centralina di comando sistemi di ritenuta



Ammortizzatore pneumatico

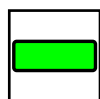

Serbatoio carburante



Batteria



Mercedes-Benz

Classe C berlina
tipo 205
a partire da 2014

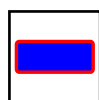
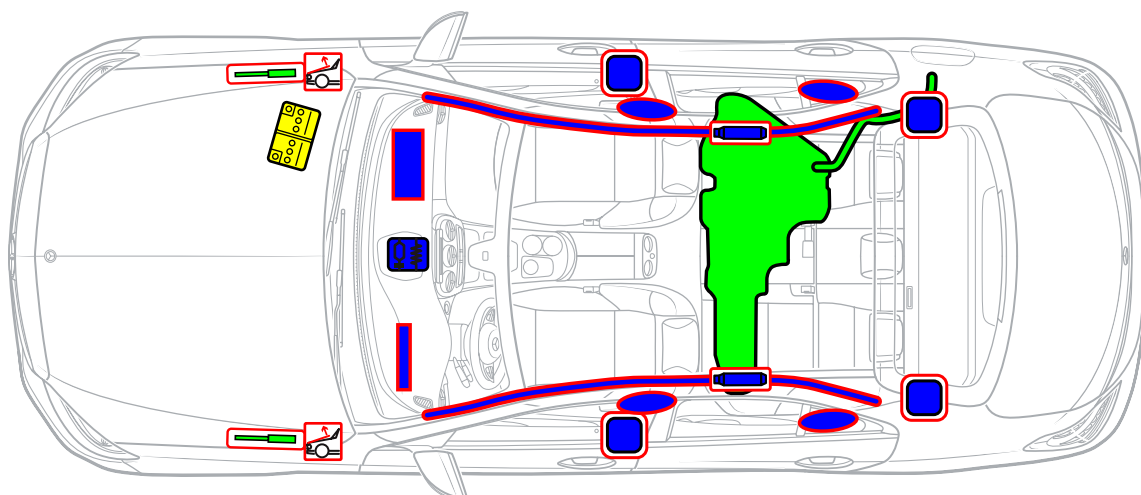
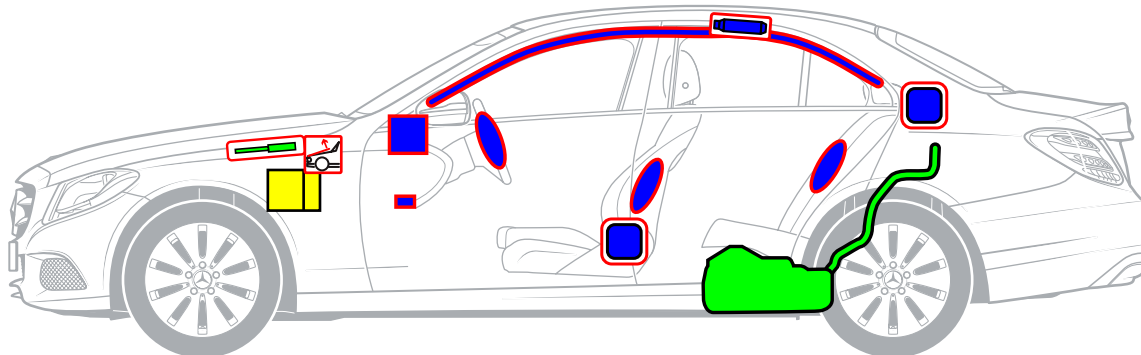

Airbag

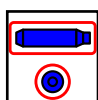

Generatore di gas

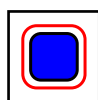

Pretensionatore

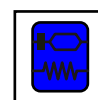

Centralina di comando
sistemi di ritenuta

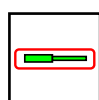

Ammortizzatore
pneumatico

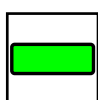

Serbatoio carburante



Protezione pedoni

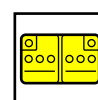

Batteria



Mercedes-Benz

Classe C HYBRID
Berlina tipo 205
a partire da 2014

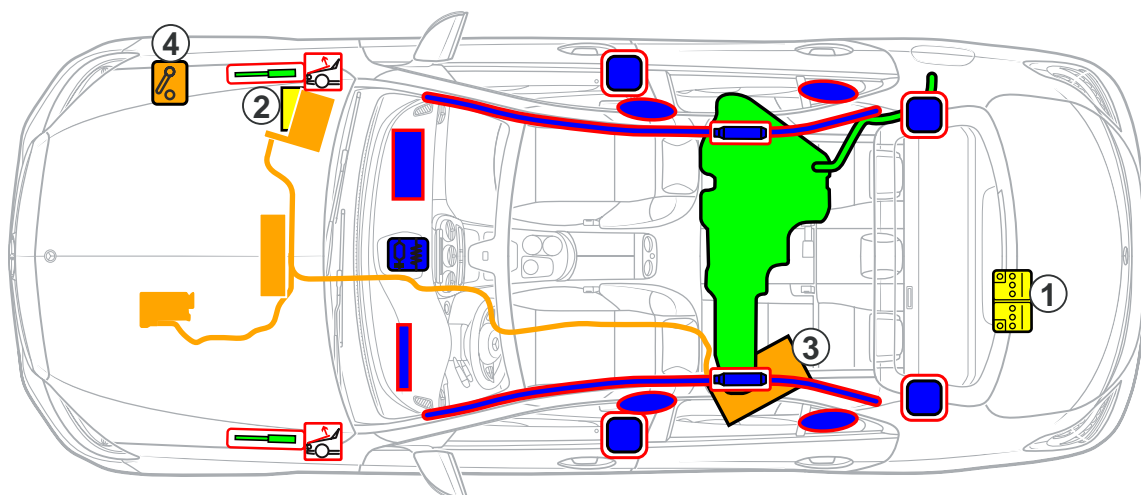
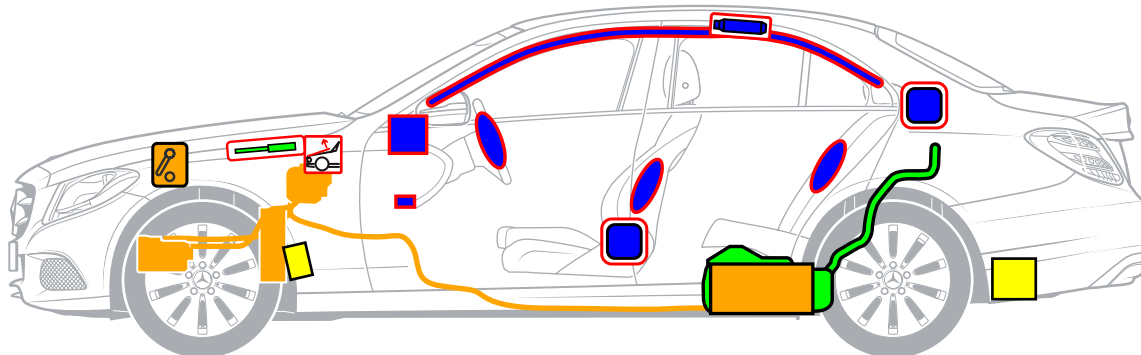

- 1 Batteria rete di bordo
- 2 Batteria supplementare
- 3 Batteria ad alto voltaggio
- 4 Dispositivo di disinserimento alto voltaggio

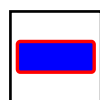

Airbag

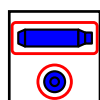

Generatore di gas

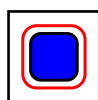

Pretensionatore

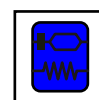

Centralina di comando sistemi di ritenuta

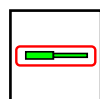

Ammortizzatore pneumatico



Protezione pedoni



Serbatoio carburante



Batteria 12 V



Batteria ad alto voltaggio



Componenti per l'alto voltaggio



Dispositivo di disinserimento alto voltaggio



Dispositivo di disinserimento alto voltaggio

Il dispositivo di disinserimento alto voltaggio si trova nel vano motore in direzione di marcia a destra, accanto al serbatoio di compensazione del liquido di raffreddamento.

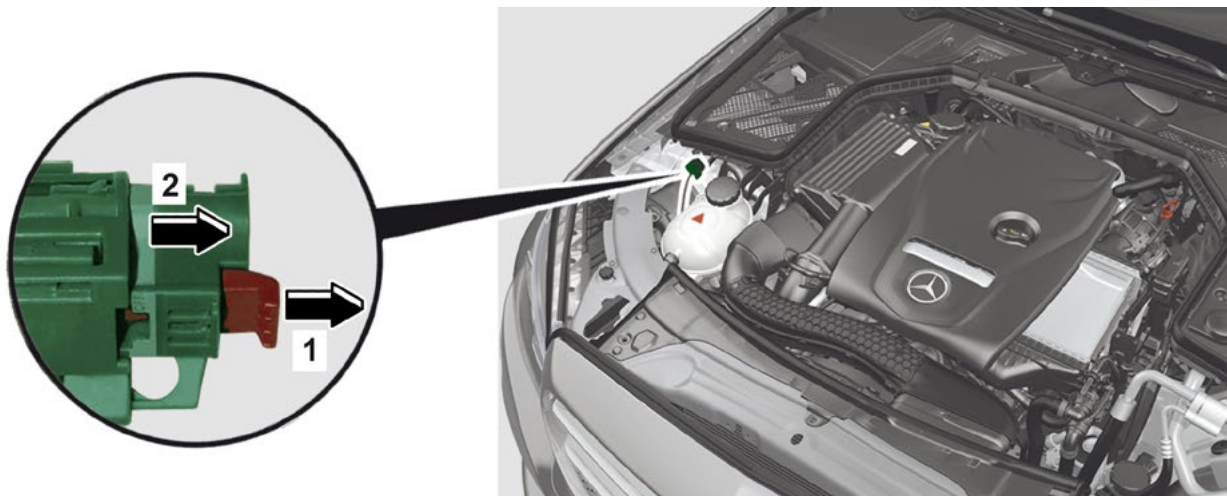

Dispositivo di disinserimento alto voltaggio nel vano motore

Azionare lo sbloccaggio (1) / Estrarre l'interruttore (2)

Identificazione veicolo



Parafango destro



Parafango sinistro

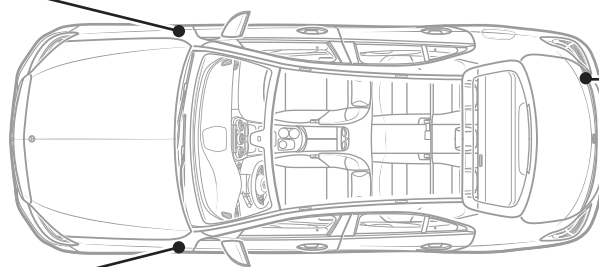

Cofano bagagli lato destro



Mercedes-Benz

Classe C HYBRID PLUS Berlina tipo 205 a partire da 2014

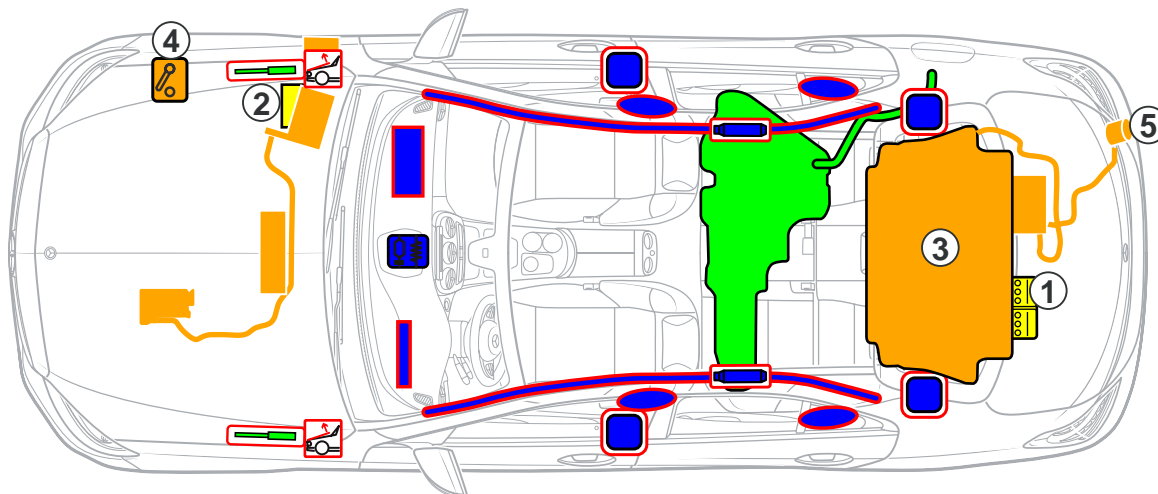
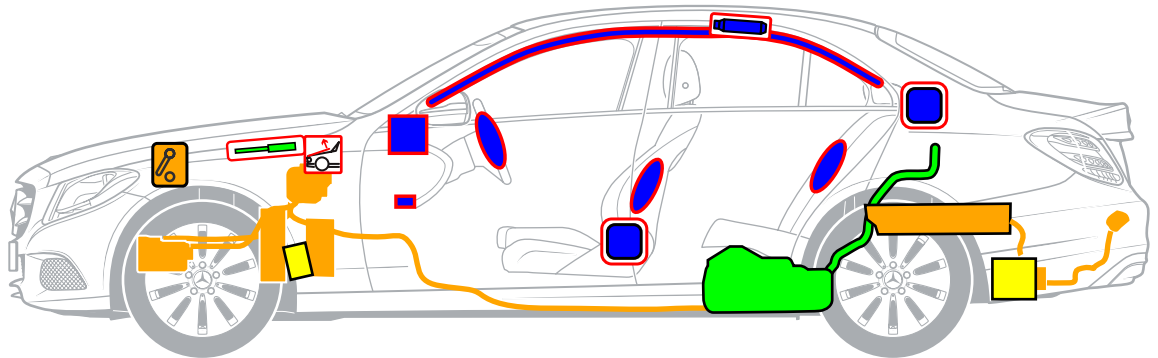

- 1 Batteria rete di bordo
- 2 Batteria supplementare
- 3 Batteria ad alto voltaggio
- 4 Dispositivo di disinserimento alto voltaggio
- 5 Presa di carica di alto voltaggio

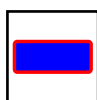

Airbag

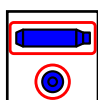

Generatore di gas

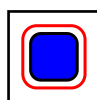

Pretensionatore

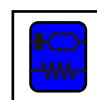

Centralina di comando sistemi di ritenuta



Ammortizzatore pneumatico



Protezione pedoni

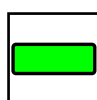

Serbatoio carburante

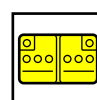

Batteria 12 V

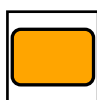

Batteria ad alto voltaggio



Componenti per l'alto voltaggio



Dispositivo di disinserimento alto voltaggio



Dispositivo di disinserimento alto voltaggio

Il dispositivo di disinserimento alto voltaggio si trova nel vano motore in direzione di marcia a destra, accanto al serbatoio di compensazione del liquido di raffreddamento.

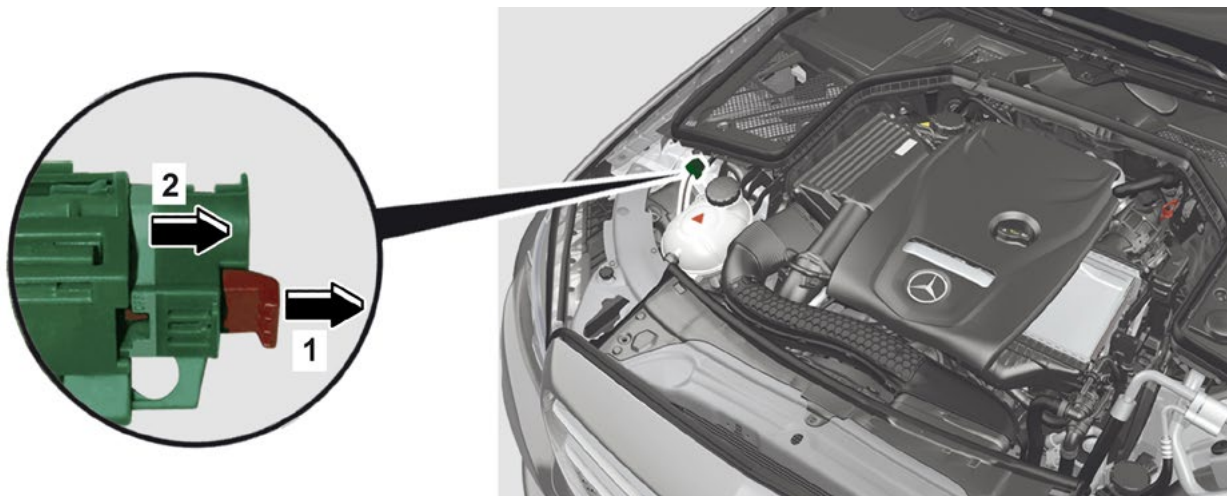

Dispositivo di disinserimento alto voltaggio nel vano motore

Azionare lo sbloccaggio (1) / Estrarre l'interruttore (2)

Identificazione veicolo

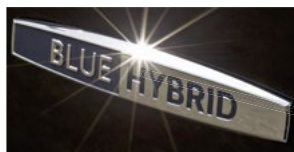

Parafango destro



Parafango sinistro

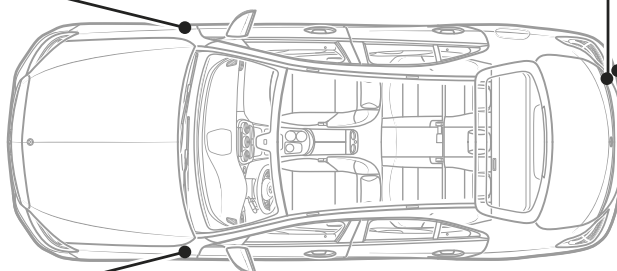

Cofano bagagli lato destro



Presa di carica di alto voltaggio



Mercedes-Benz

Classe E berlina
tipo 123
1975 - 1986

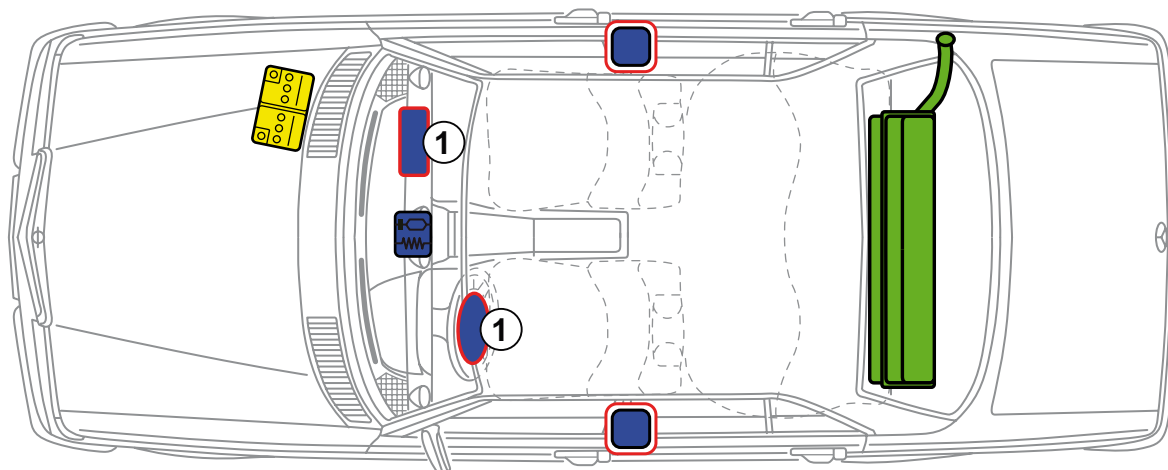
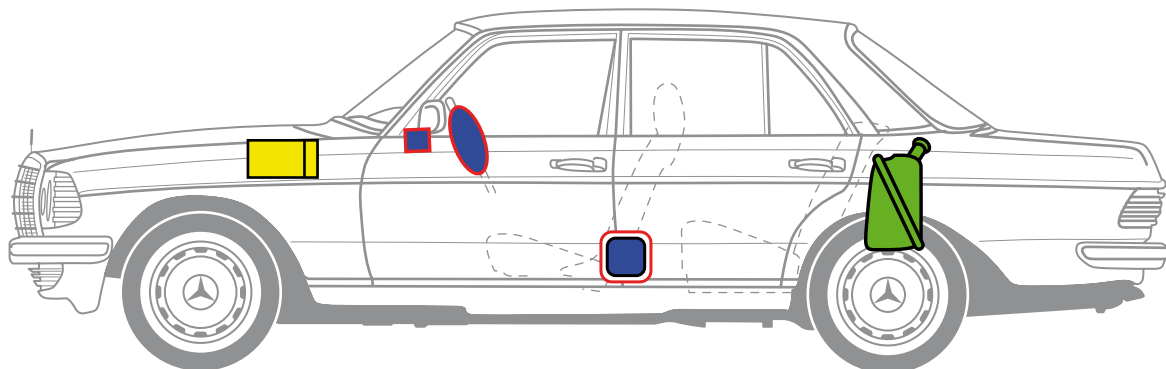

1 A partire da 1980



Airbag

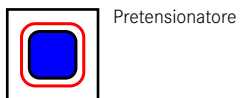

Pretensionatore

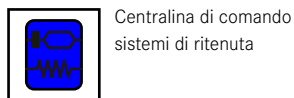

Centralina di comando
sistemi di ritenuta



Serbatoio carburante

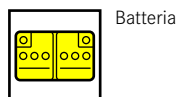

Batteria



Mercedes-Benz

Classe E berlina
tipo 124
1984 - 1995

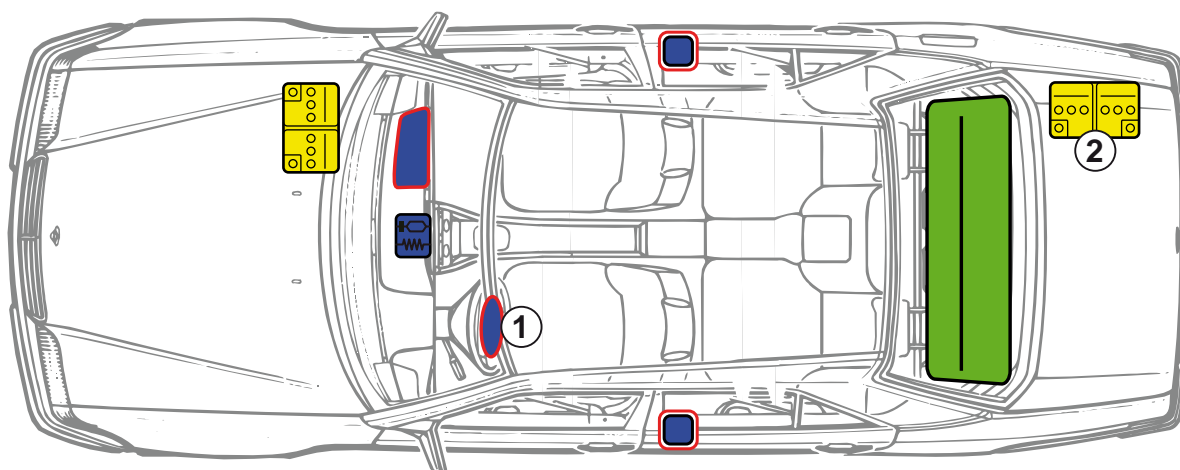
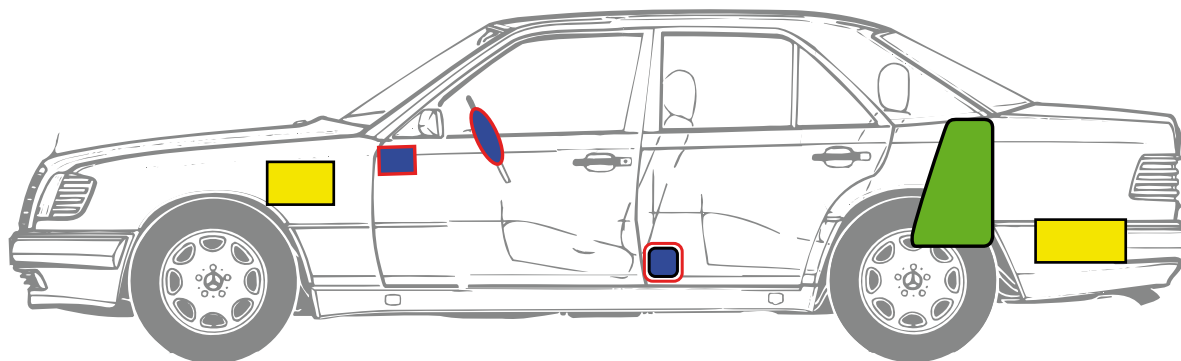

- 1 A partire da 1992 di serie
- 2 Batteria nel bagagliaio in caso di motore a 8 cilindri



Airbag

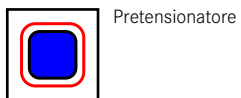

Pretensionatore

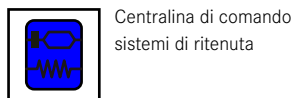

Centralina di comando
sistemi di ritenuta

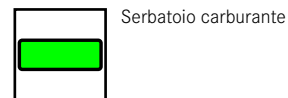

Serbatoio carburante

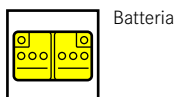

Batteria



Mercedes-Benz

Classe E berlina
tipo 210
1995 - 2002

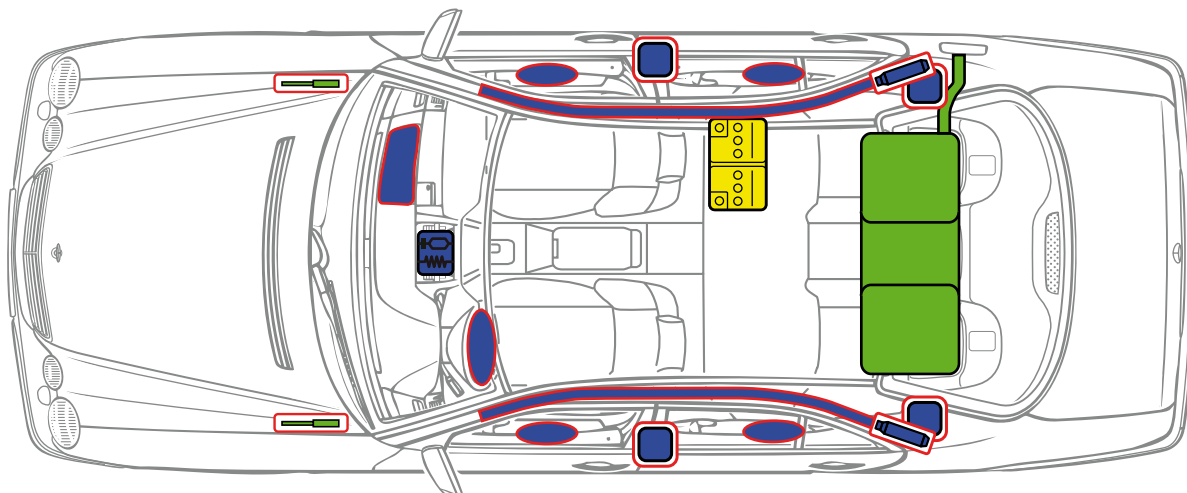
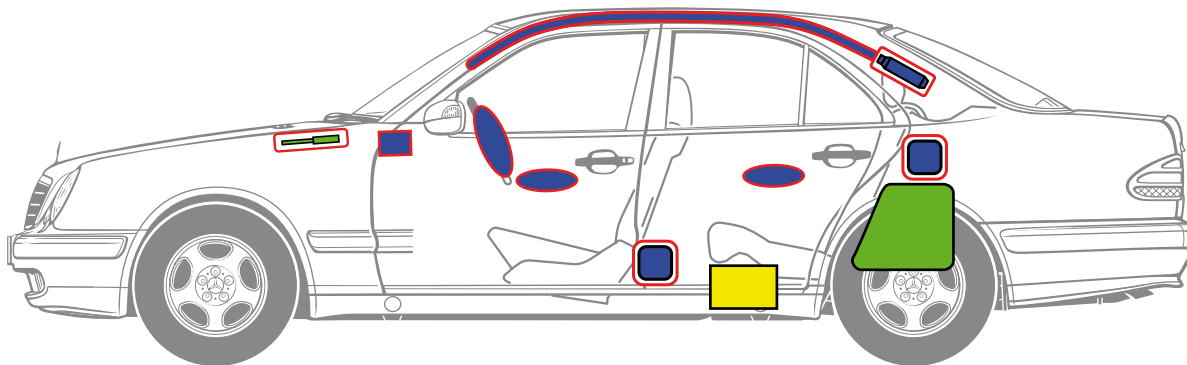

Airbag



Generatore di gas



Pretensionatore



Centralina di comando
sistemi di ritenuta



Ammortizzatore
pneumatico



Serbatoio carburante



Batteria



Mercedes-Benz

Classe E berlina
tipo 211
2002 - 2009

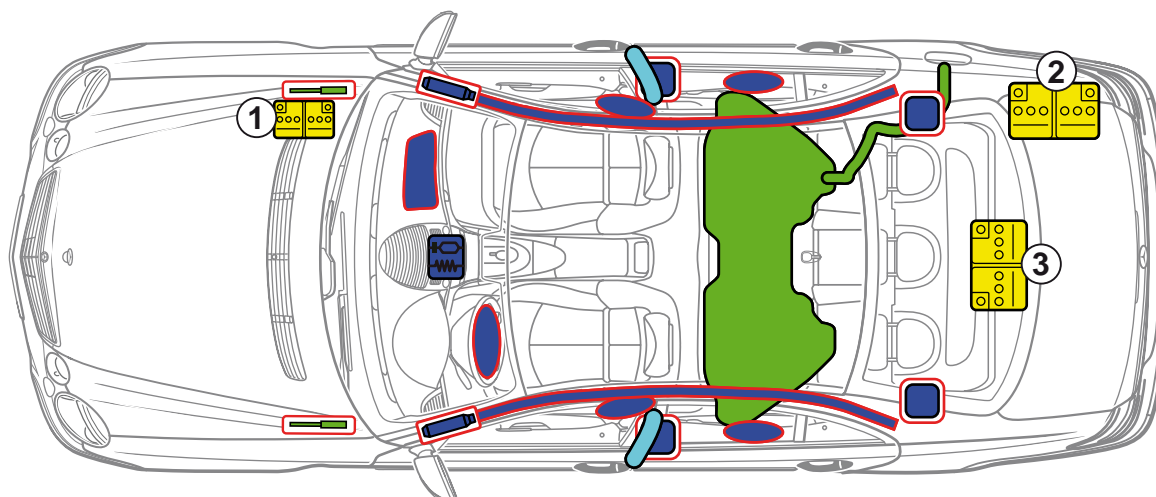
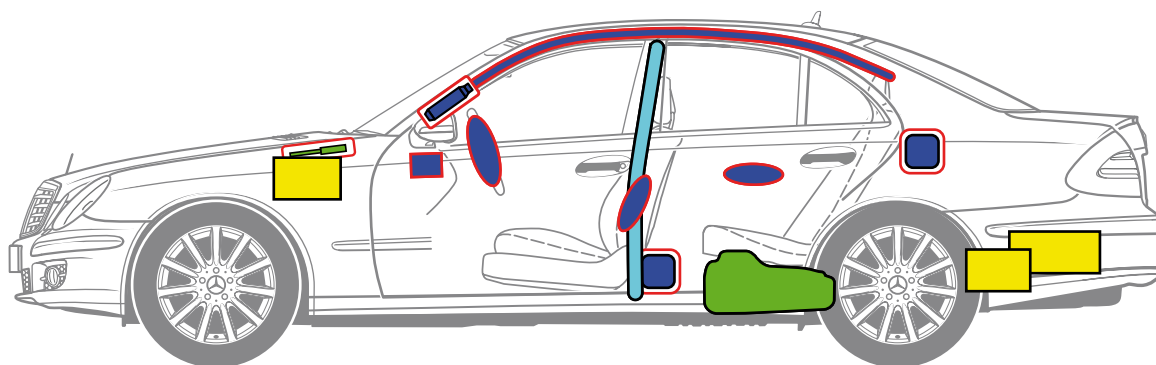

- 1 Batteria supplementare vano motore (fino a 31.05.2006)
- 2 Batteria principale bagagliaio (in caso di equipaggiamento con ruota di scorta)
- 3 Batteria principale bagagliaio (in caso di equipaggiamento senza ruota di scorta)



Airbag



Generatore di gas



Pretensionatore



Centralina di comando sistemi di ritenuta



Ammortizzatore pneumatico



Rinforzo carrozzeria



Serbatoio carburante



Batteria



Mercedes-Benz

Classe E NGT berlina
tipo 211
2004 - 2009

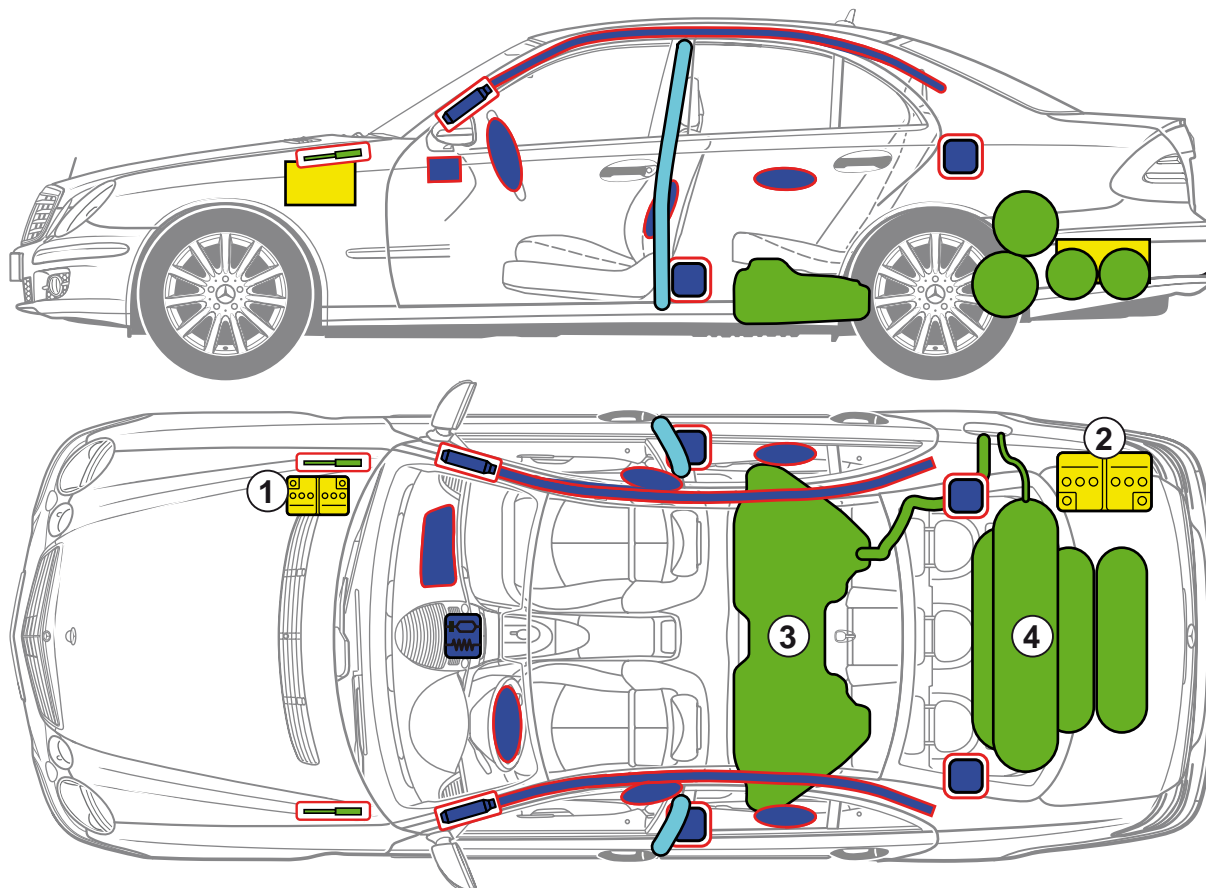

- 1 Batteria supplementare vano motore
- 2 Batteria principale bagagliaio
- 3 Serbatoio carburante
- 4 Serbatoio gas



Airbag

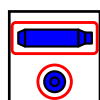

Generatore di gas

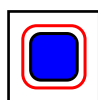

Pretensionatore

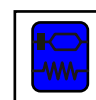

Centralina di comando sistemi di ritenuta

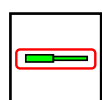

Ammortizzatore pneumatico

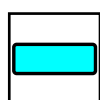

Rinforzo carrozzeria

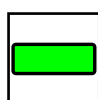

Serbatoio carburante

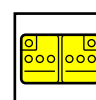

Batteria



Mercedes-Benz

Classe E NGT berlina
tipo 211
2004 - 2009



Identificazione veicolo

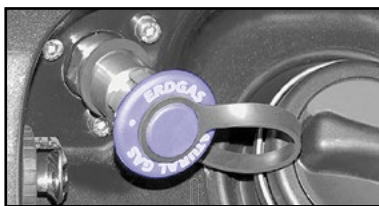

Bocchettone di rifornimento metano

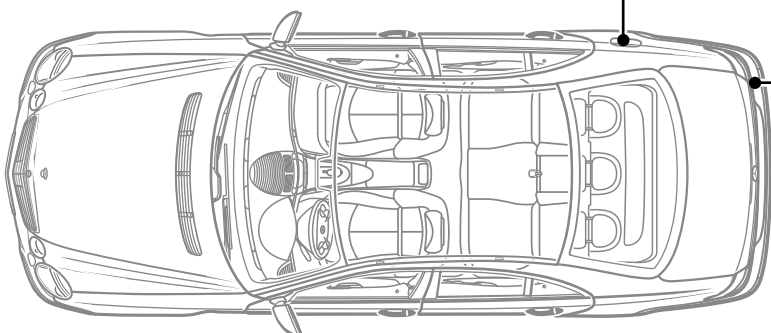

Cofano bagagli lato destro



Mercedes-Benz

Classe E berlina
tipo 212
2009 - 2012

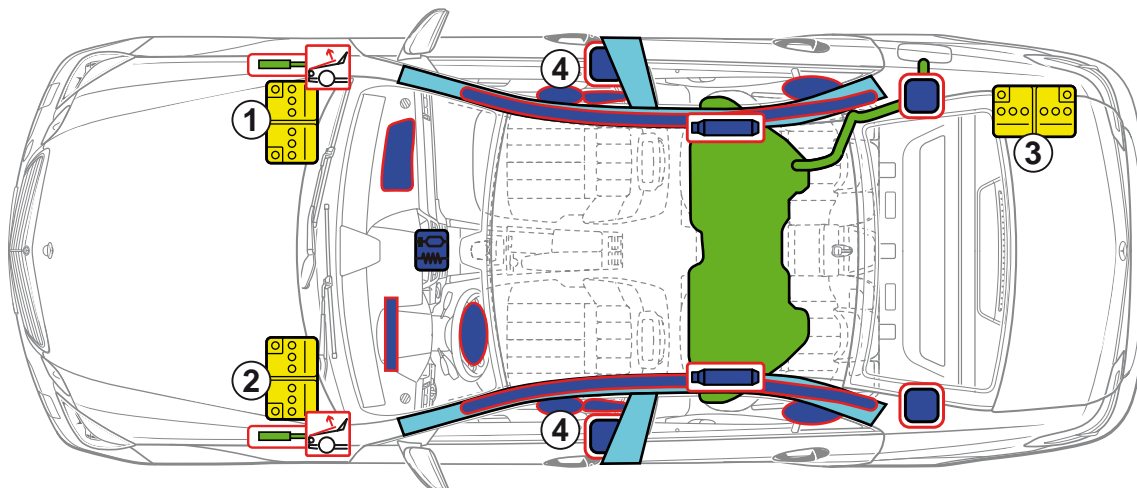
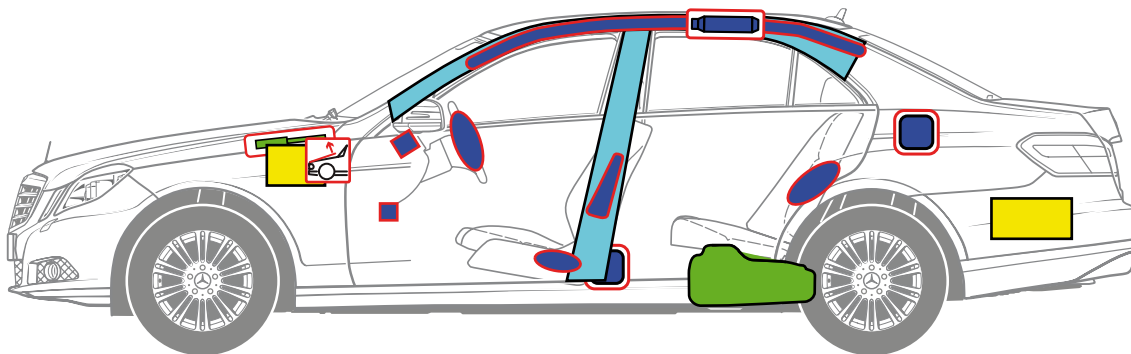
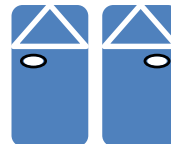

- 1 Veicolo con guida a sinistra, in caso di motore a 4 o 6 cilindri, motore a 8 cilindri a partire dall'anno di produzione 2011
- 2 Veicolo con guida a destra, in caso di motore a 4 o 6 cilindri, motore a 8 cilindri a partire dall'anno di produzione 2011
- 3 In caso di motore a 8 cilindri (fino all'anno di produzione 2011)
- 4 Airbag per il bacino (a partire da 06.2009)



Airbag



Generatore di gas



Pretensionatore



Centralina di comando sistemi di ritenuta



Ammortizzatore pneumatico



Rinforzo carrozzeria



Protezione pedoni



Serbatoio carburante



Batteria



Mercedes-Benz

Classe E berlina anno di produzione 2013
tipo 212
a partire da 2013

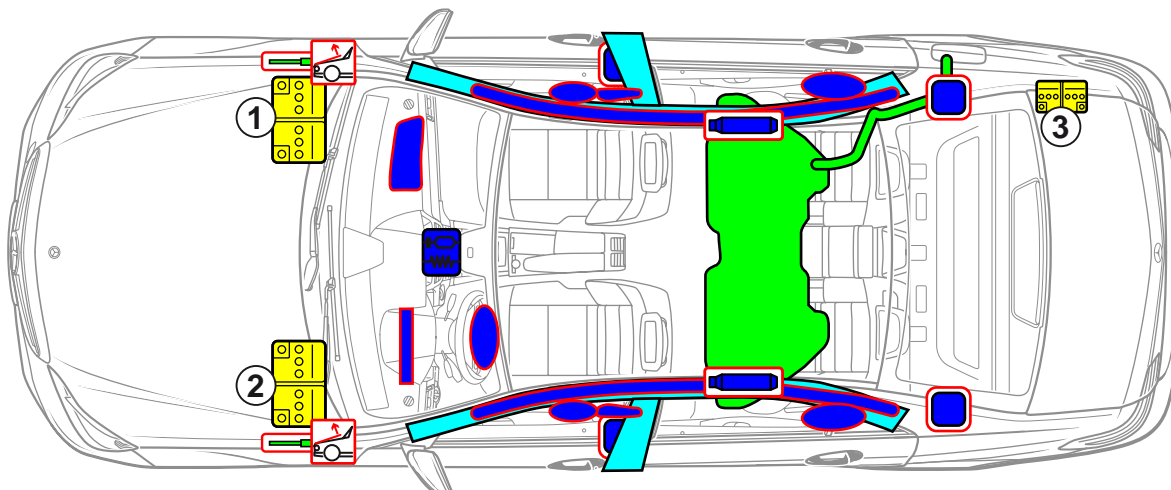
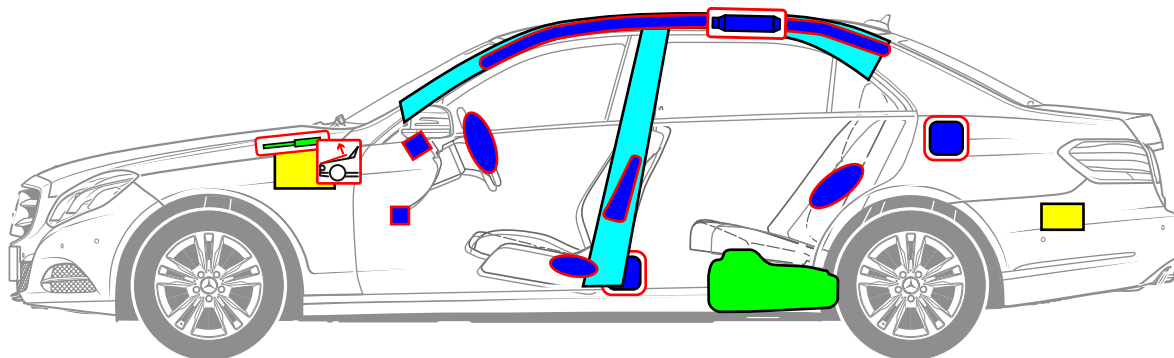
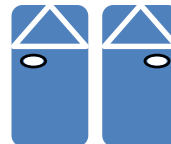

- 1 Veicolo con guida a sinistra
- 2 Veicolo con guida a destra
- 3 Batteria supplementare (opzionale)

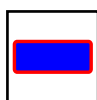

Airbag

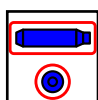

Generatore di gas

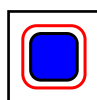

Pretensionatore

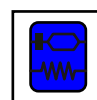

Centralina di comando sistemi di ritenuta



Ammortizzatore pneumatico



Rinforzo carrozzeria



Protezione pedoni



Serbatoio carburante

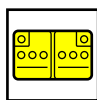

Batteria



Mercedes-Benz

Classe E NGT berlina
tipo 212
a partire da 2010

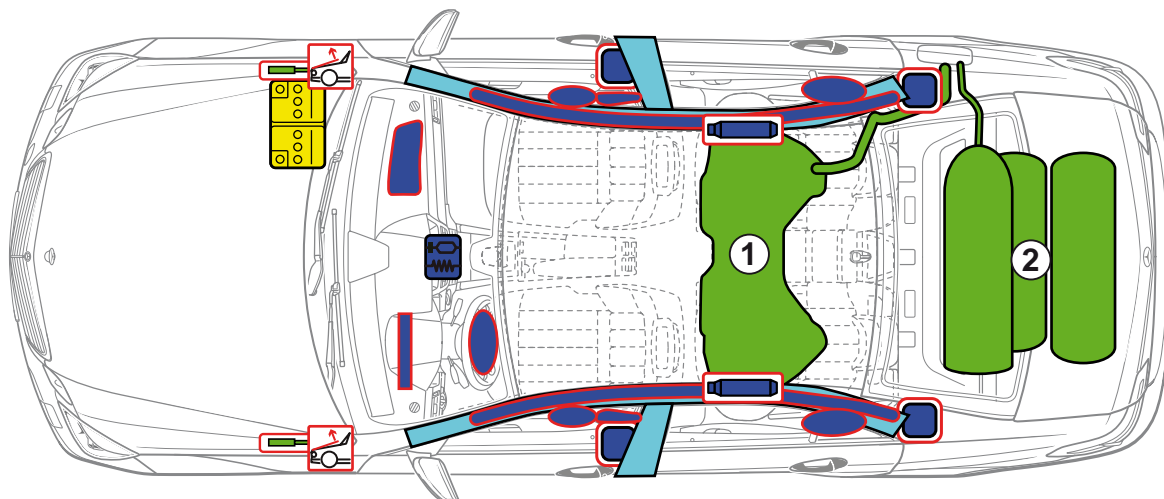
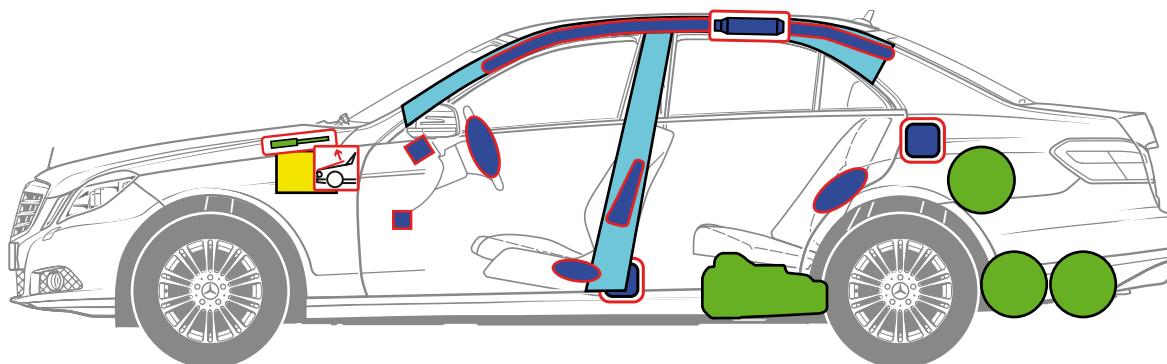

- 1 Serbatoio carburante
- 2 Serbatoio gas

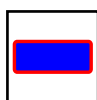

Airbag

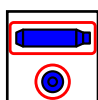

Generatore di gas

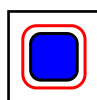

Pretensionatore

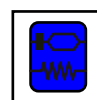

Centralina di comando sistemi di ritenuta



Ammortizzatore pneumatico



Rinforzo carrozzeria



Protezione pedoni



Serbatoio carburante

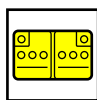

Batteria



Mercedes-Benz

Classe E NGT berlina
tipo 212
a partire da 2010



Identificazione veicolo



Bocchettone di rifornimento metano

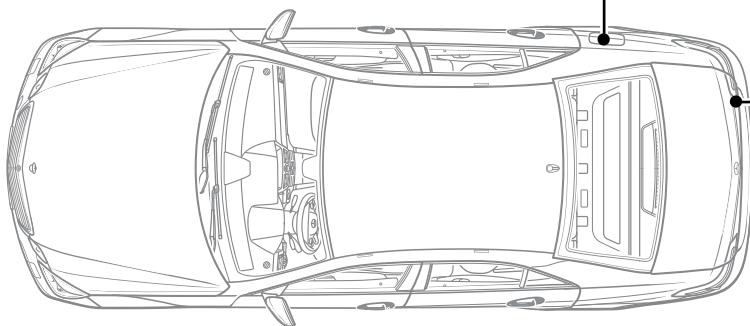

Cofano bagagli lato destro



Mercedes-Benz

Classe E HYBRID berlina tipo 212 a partire da 2012

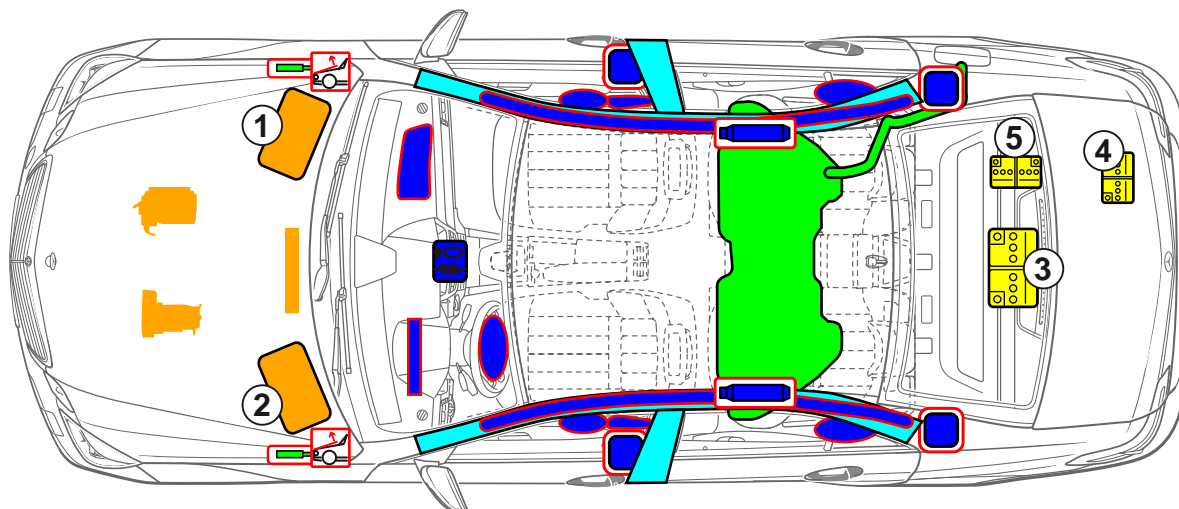
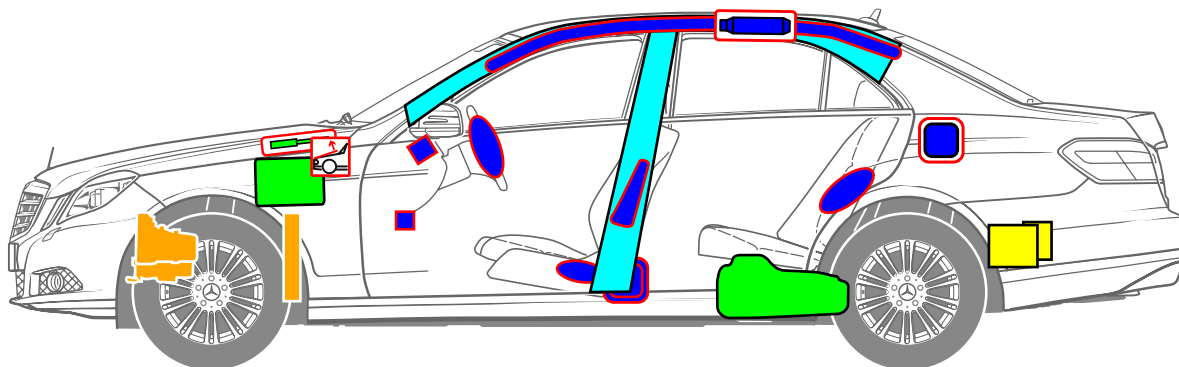
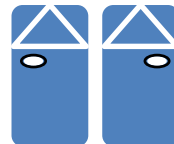

- 1 Batteria ad alto voltaggio, veicolo con guida a sinistra
- 2 Batteria ad alto voltaggio, veicolo con guida a destra
- 3 Batteria principale 12 V
- 4 Batteria supplementare, veicolo con guida a sinistra (opzionale)
- 5 Batteria supplementare, veicolo con guida a destra (opzionale)



Airbag



Generatore di gas



Pretensionatore



Centralina di comando sistemi di ritenuta



Ammortizzatore pneumatico



Rinforzo carrozzeria



Protezione pedoni



Serbatoio carburante



Batteria 12 V



Batteria ad alto voltaggio



Componenti per l'alto voltaggio



Mercedes-Benz

Classe E HYBRID berlina
tipo 212
a partire da 2012

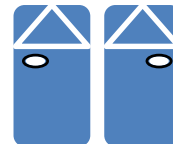

Identificazione veicolo



Parafango destro



Parafango sinistro

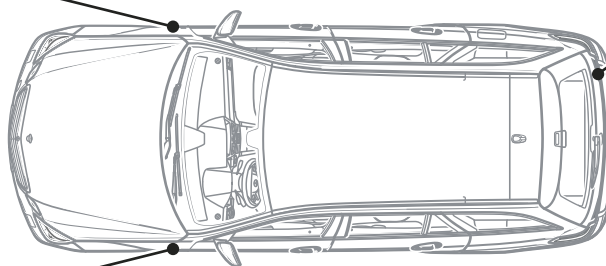

Cofano bagagli lato destro





Mercedes-Benz

Classe S berlina
tipo 116
1972 - 1980

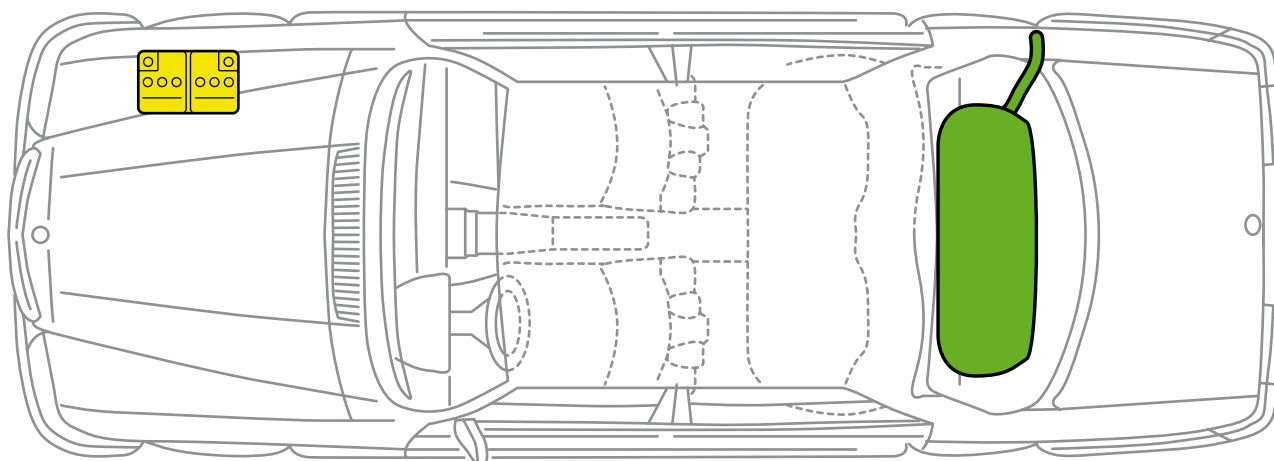
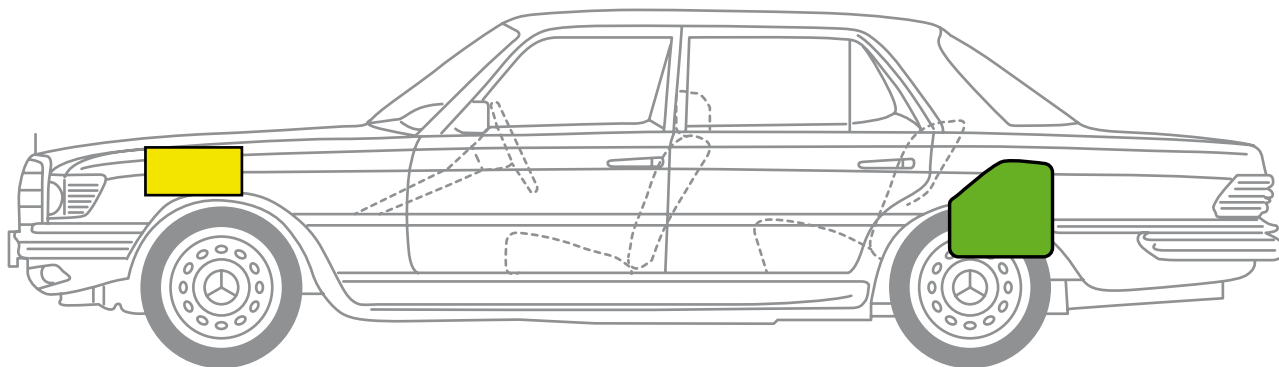

Serbatoio carburante



Batteria



Mercedes-Benz

Classe S berlina
tipo 126
1979 -1991

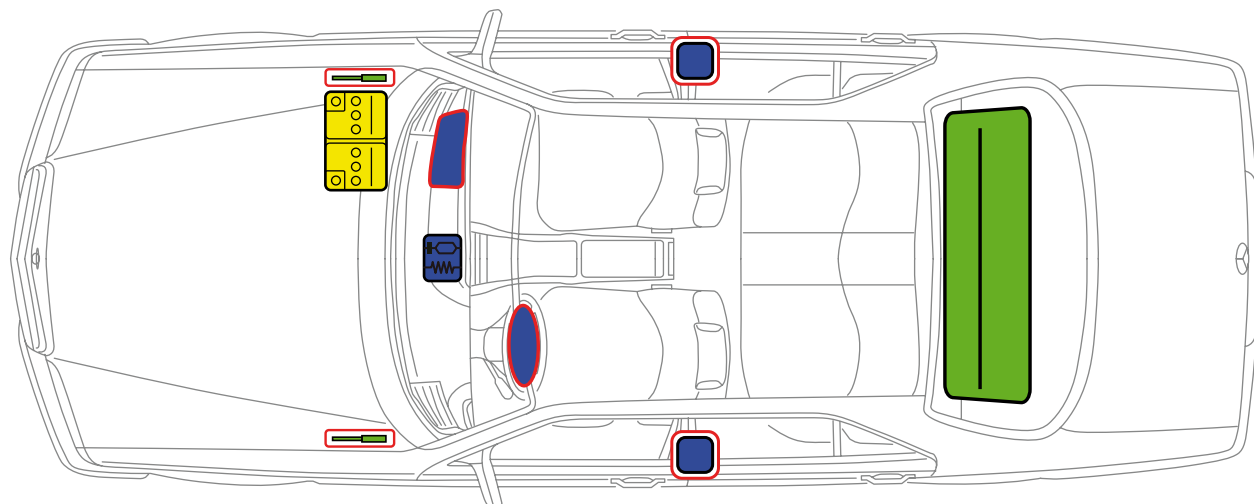
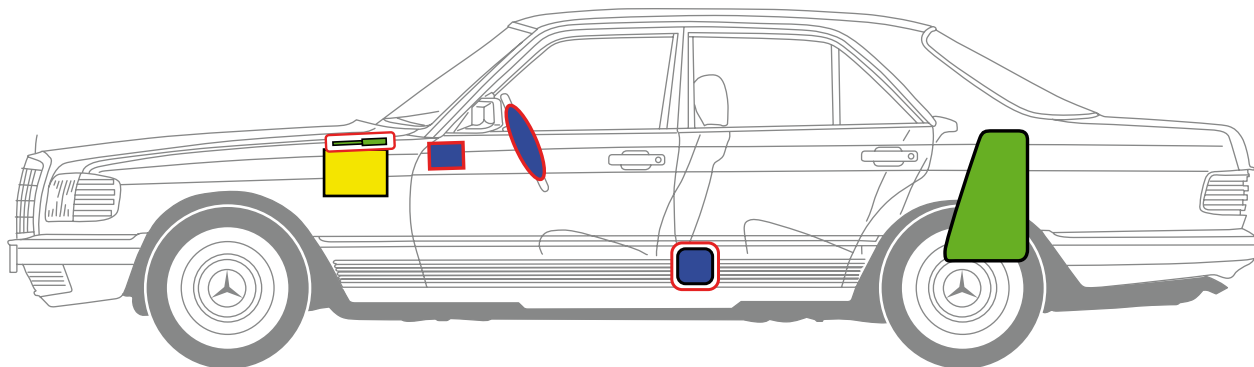

Airbag



Pretensionatore



Centralina di comando
sistemi di ritenuta



Ammortizzatore
pneumatico



Serbatoio carburante



Batteria



Mercedes-Benz

Classe S berlina
tipo 140
1991 - 1998

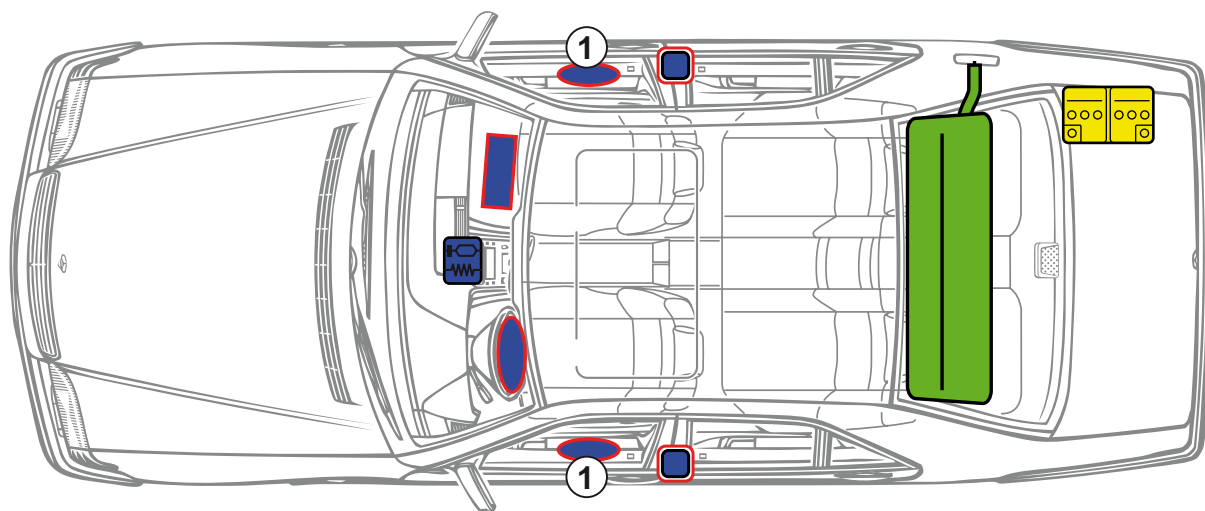
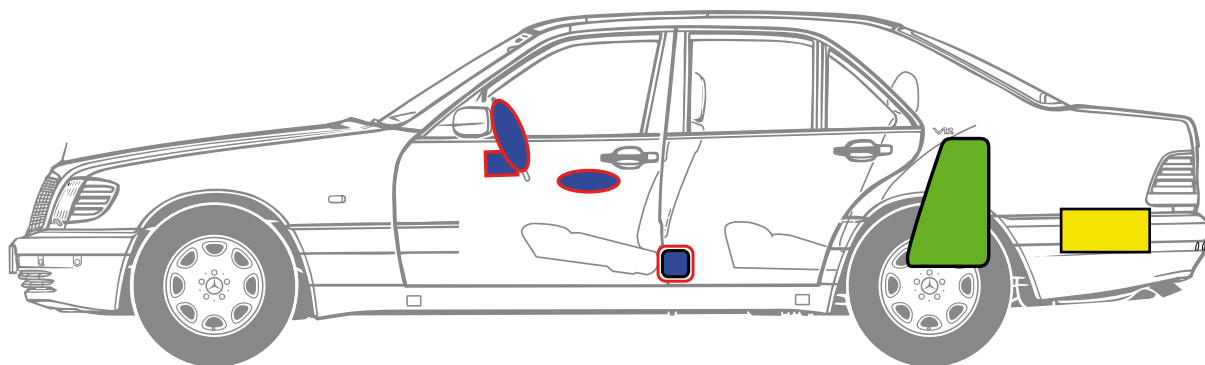

1 Equipaggiamento speciale



Airbag

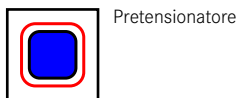

Pretensionatore

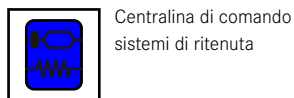

Centralina di comando
sistemi di ritenuta

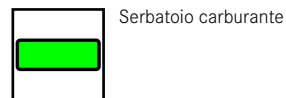

Serbatoio carburante

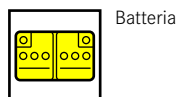

Batteria



Mercedes-Benz

Classe S Pullman berlina
tipo 140
1996 - 2000

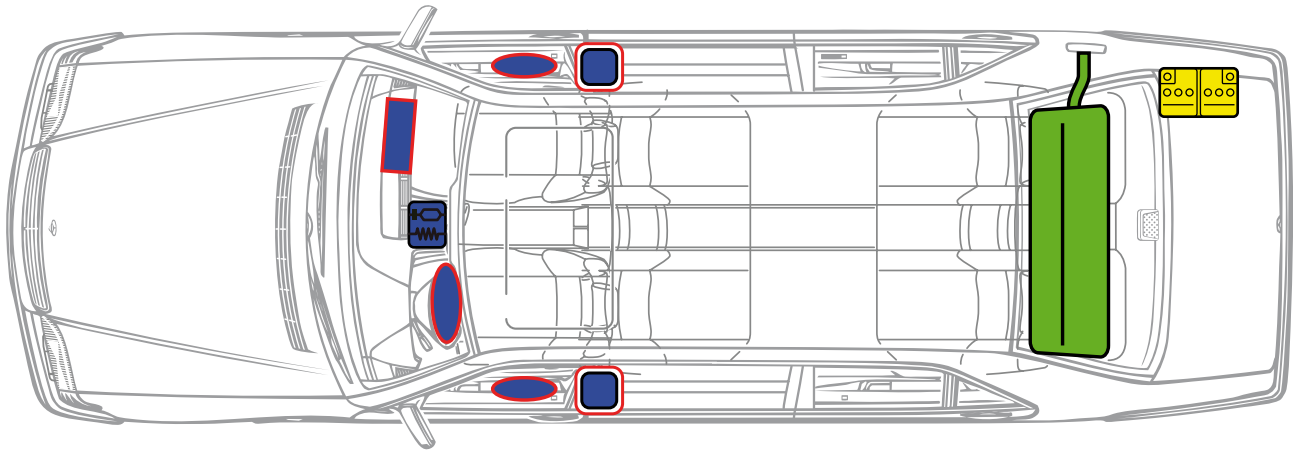
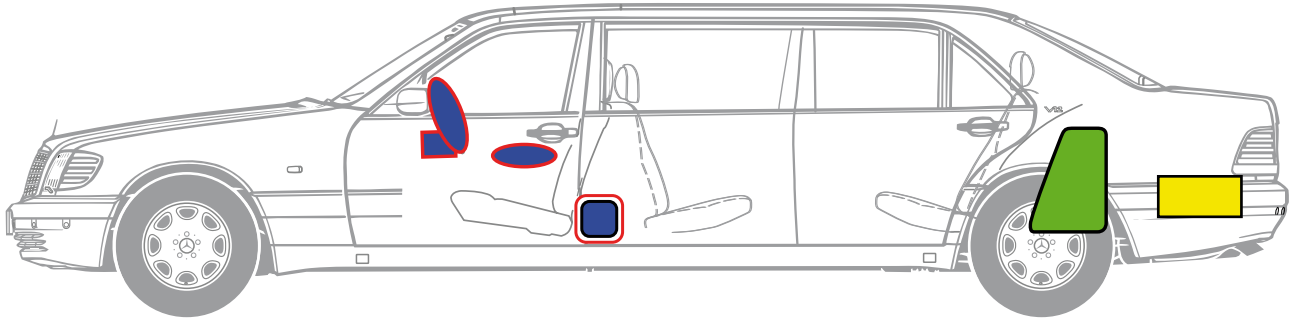

Airbag

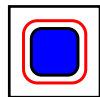

Pretensionatore



Centralina di comando
sistemi di ritenuta



Serbatoio carburante



Batteria



Mercedes-Benz

Classe S berlina
tipo 220
1998 - 2005

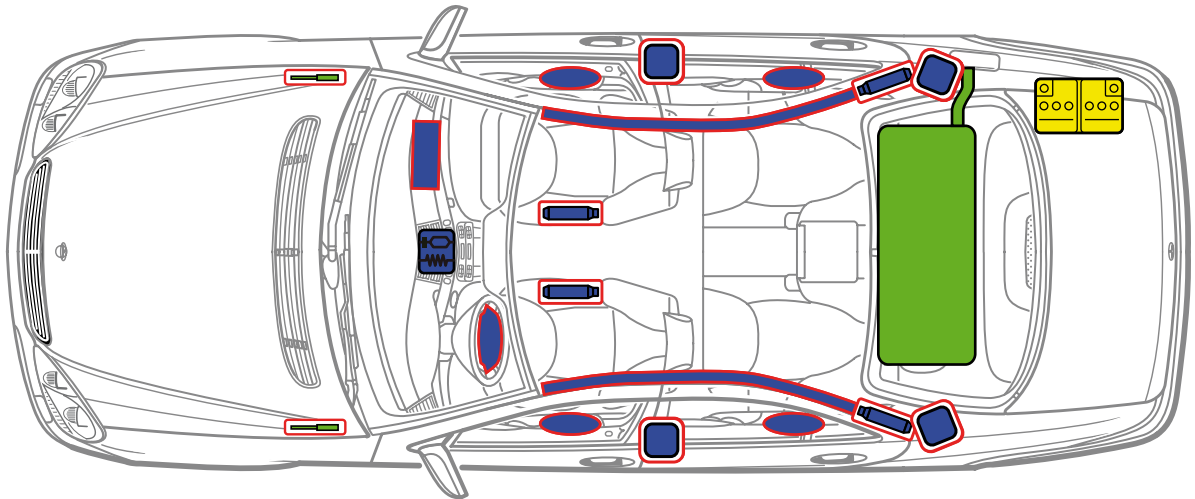
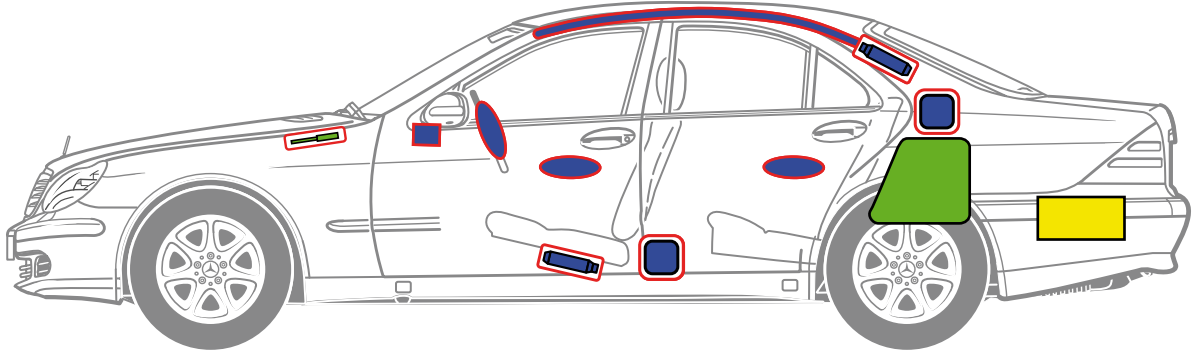

Airbag

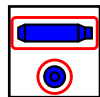

Generatore di gas



Pretensionatore



Centralina di comando
sistemi di ritenuta



Ammortizzatore
pneumatico

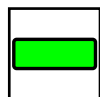

Serbatoio carburante



Batteria



Mercedes-Benz

Classe S Pullman berlina
tipo 220
2000 - 2005

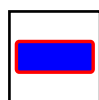
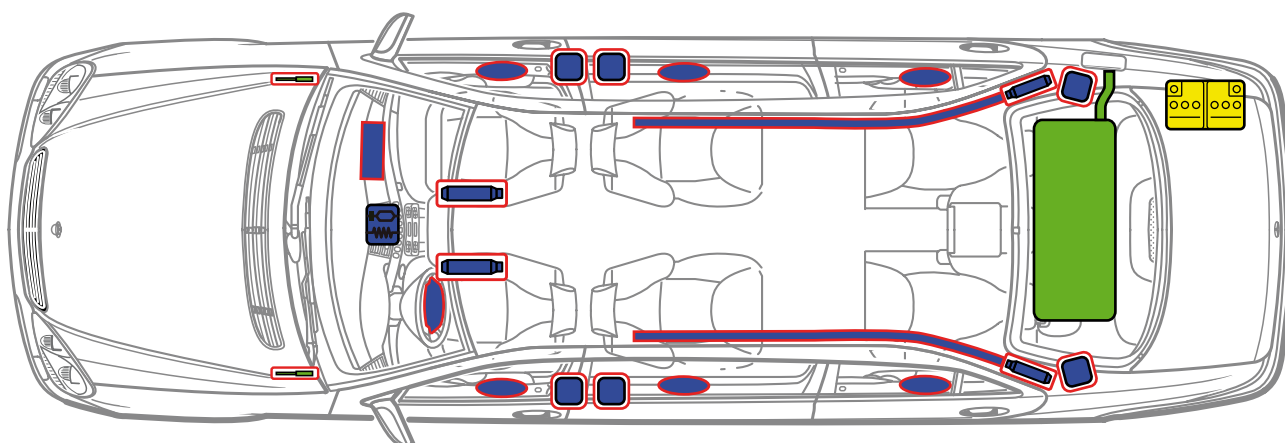
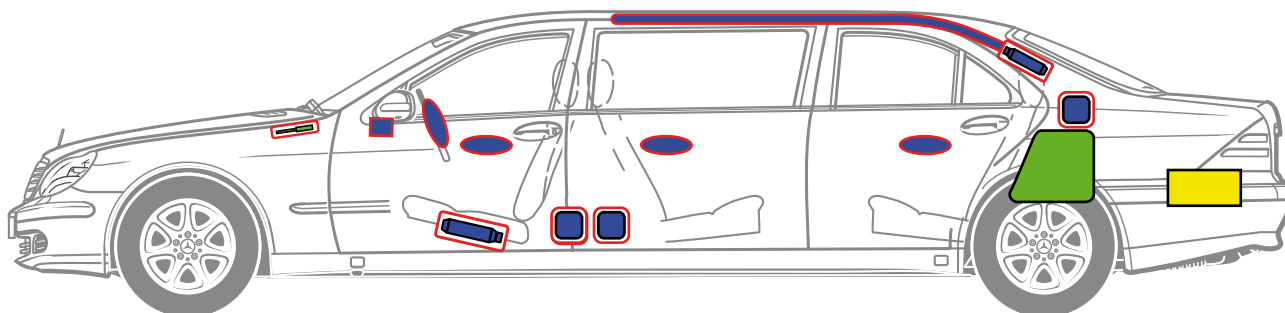

Airbag

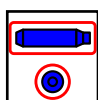

Generatore di gas

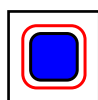

Pretensionatore

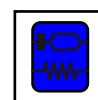

Centralina di comando
sistemi di ritenuta



Ammortizzatore
pneumatico



Serbatoio carburante



Batteria



Mercedes-Benz

Classe S berlina
tipo 221
2005 - 2013

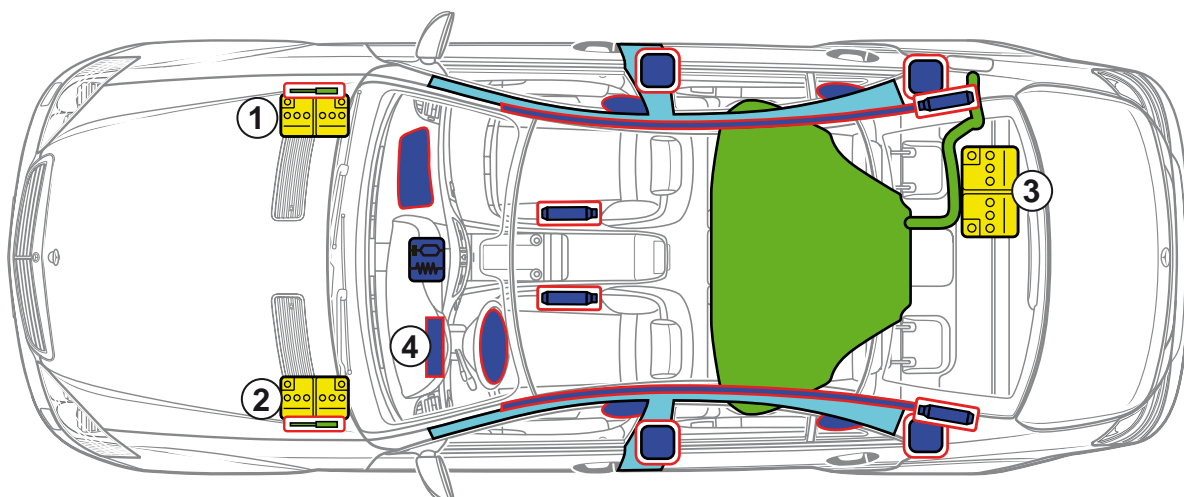
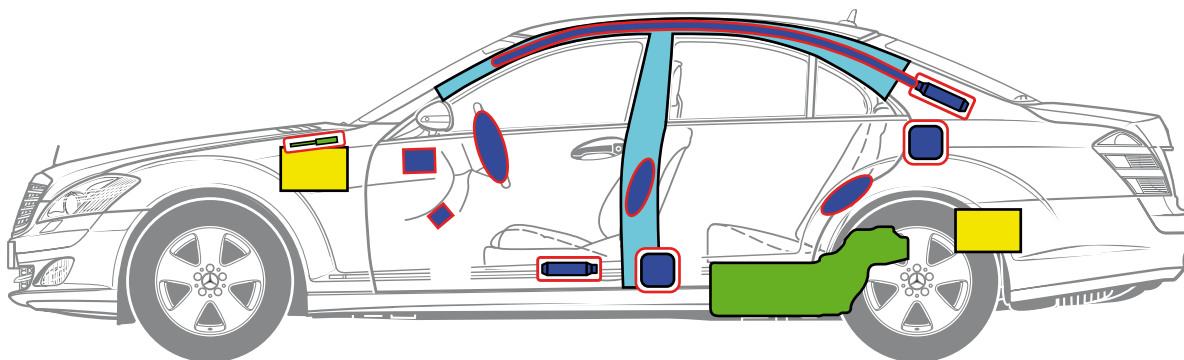
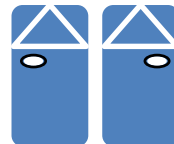

- 1 Batteria vano motore, veicolo con guida a sinistra
- 2 Batteria vano motore, veicolo con guida a destra
- 3 Batteria bagagliaio (fino a 08.2008)
- 4 Airbag per le ginocchia conducente (a partire da 09.2008)



Airbag



Generatore di gas



Pretensionatore



Centralina di comando sistemi di ritenuta



Ammortizzatore pneumatico



Rinforzo carrozzeria



Serbatoio carburante



Batteria



Mercedes-Benz

Classe S HYBRID berlina
tipo 221
2009 - 2013

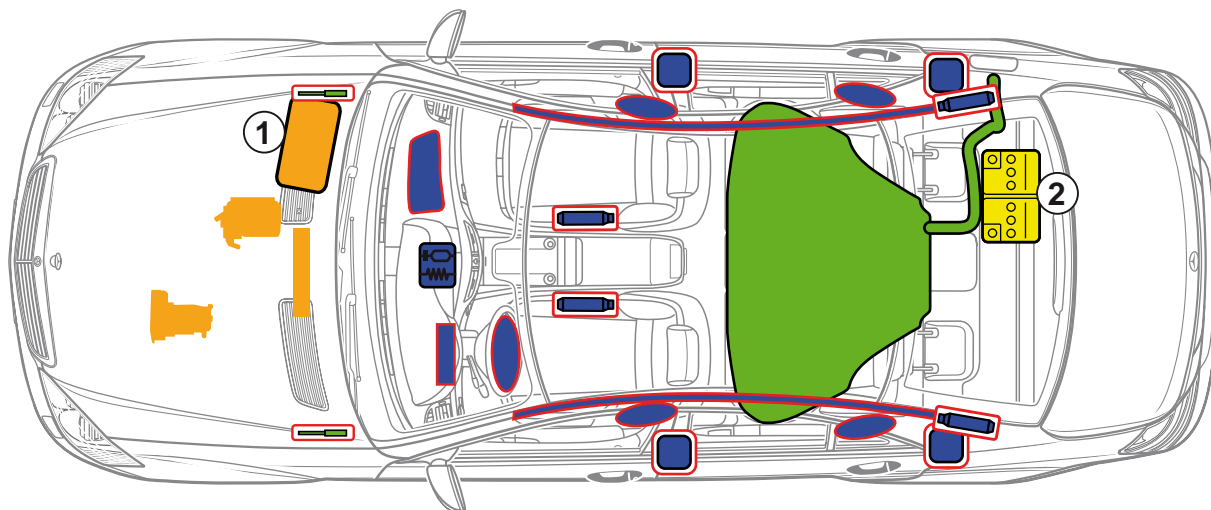
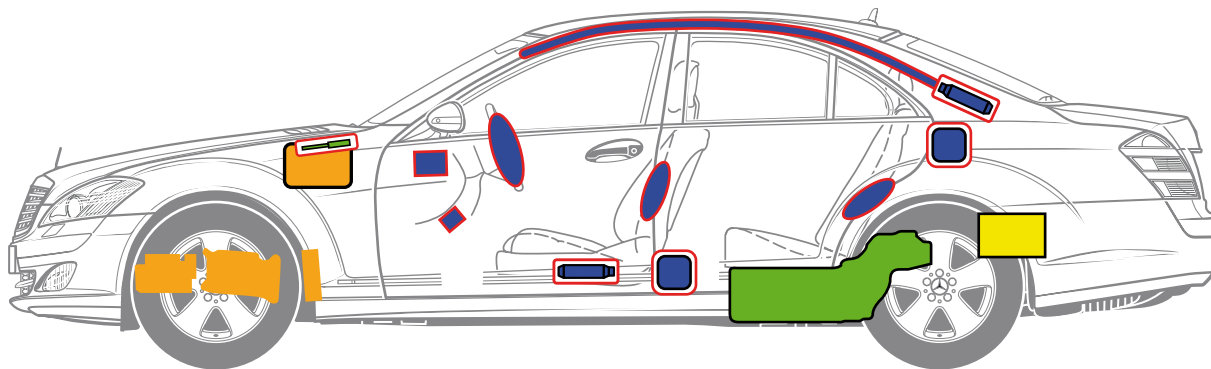

- 1 Batteria ad alto voltaggio
- 2 Batteria rete di bordo 12 V

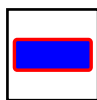

Airbag

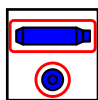

Generatore di gas

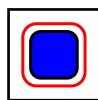

Pretensionatore

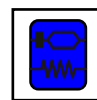

Centralina di comando sistemi di ritenuta



Ammortizzatore pneumatico



Serbatoio carburante



Batteria 12 V



Batteria ad alto voltaggio



Componenti per l'alto voltaggio



Identificazione veicolo



Parafango destro

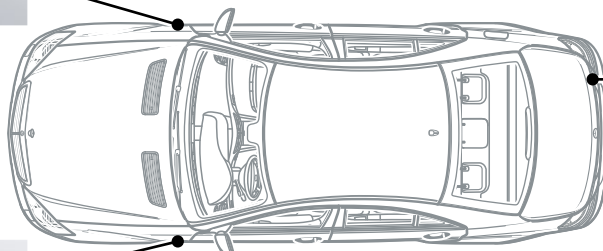

Cofano bagagli lato destro



Parafango sinistro



Mercedes-Benz

Classe S berlina
tipo 222
a partire da 2013

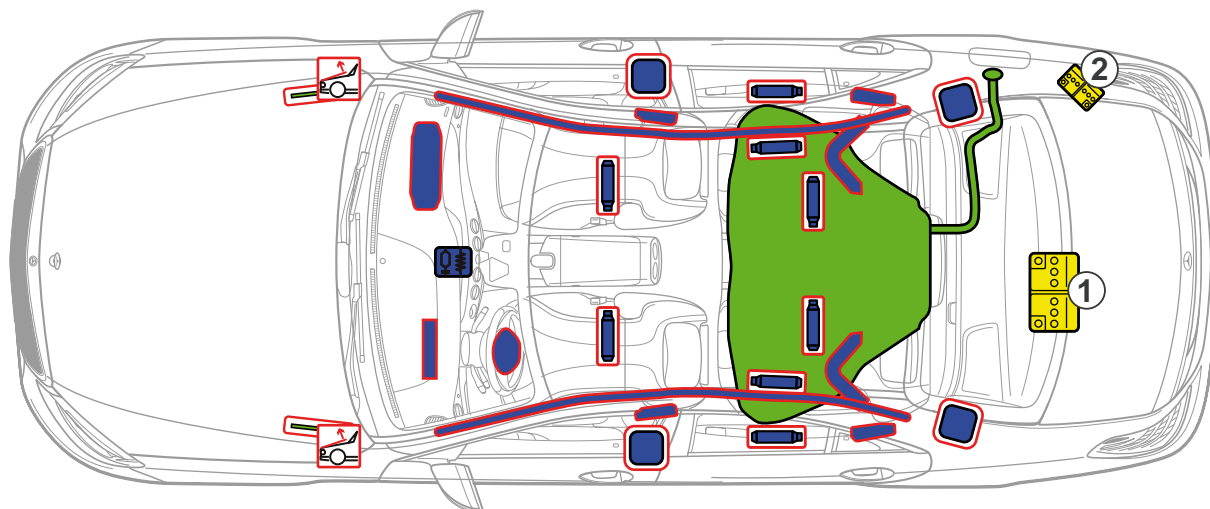
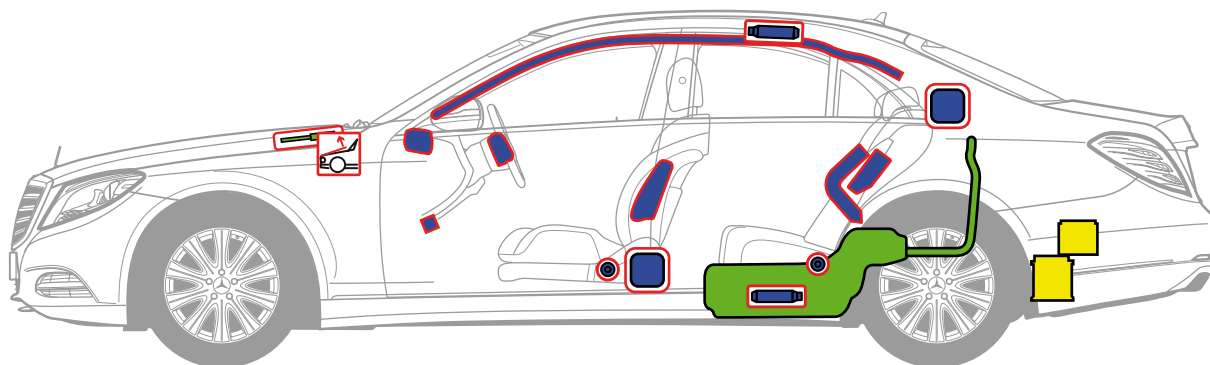

- 1 Batteria principale
- 2 Batteria supplementare



Airbag



Generatore di gas



Pretensionatore



Gurtbag



Centralina di comando sistemi di ritenuta



Ammortizzatore pneumatico



Protezione pedoni



Seratoio carburante



Batteria



Mercedes-Benz

Classe S HYBRID berlina
tipo 222
a partire da 2013

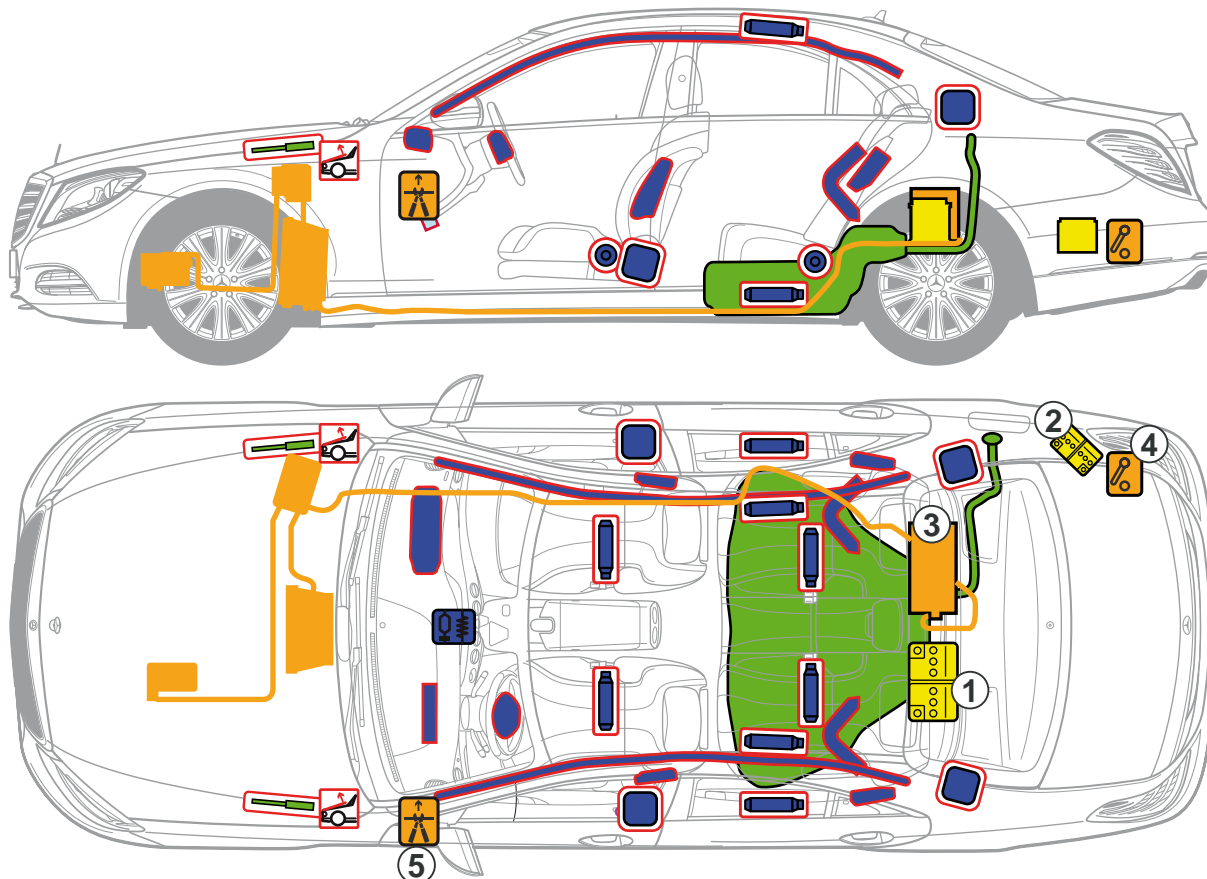

- 1 Batteria principale (12 V)
- 2 Batteria supplementare (12 V)
- 3 Batteria ad alto voltaggio
- 4 Dispositivo di disinserimento alto voltaggio
- 5 Dispositivo alternativo di disinserimento alto voltaggio

ⓘ Avvertenza
 Il dispositivo alternativo di disinserimento alto voltaggio va utilizzato solo se non è possibile accedere al dispositivo di disinserimento alto voltaggio nel bagagliaio.

	Airbag		Generatore di gas		Pretensionatore		Gurtbag
	Centralina di comando sistemi di ritenuta		Ammortizzatore pneumatico		Protezione pedoni		Serbatoio carburante
	Batteria 12 V		Batteria ad alto voltaggio		Componenti per l'alto voltaggio		Dispositivo di disinserimento alto voltaggio
	Dispositivo alternativo di disinserimento alto voltaggio						



Dispositivo di disinserimento alto voltaggio

Sotto la copertura della cavità del bagagliaio nella parte posteriore destra si trova il dispositivo di disinserimento alto voltaggio.

Il rivestimento della cavità viene tirato fuori dal bagagliaio tramite la linguetta di trazione al di sotto del bordo di carico al centro del veicolo. La linguetta di trazione è contrassegnata tramite il simbolo  .

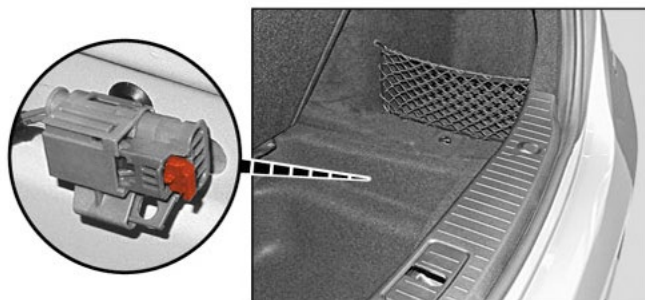

Dispositivo di disinserimento alto voltaggio nel bagagliaio

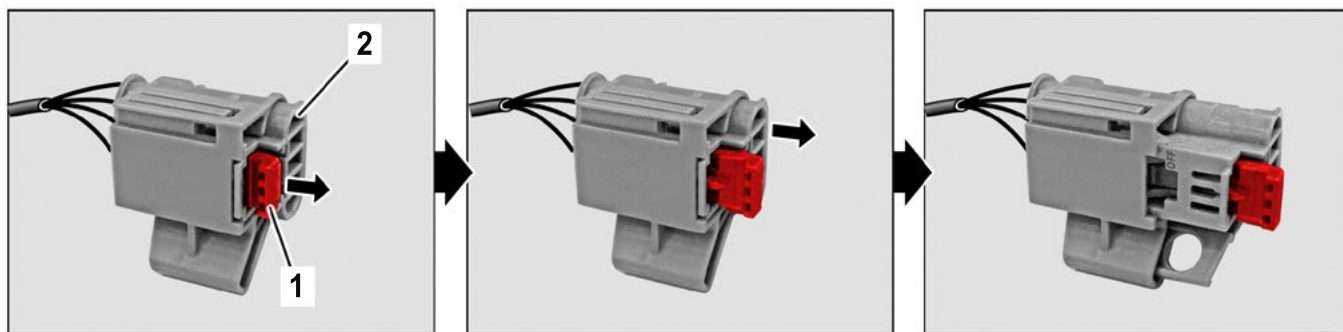

Tirare lo sbloccaggio (1) / Estrarre l'interruttore (2)

Dispositivo alternativo di disinserimento alto voltaggio

Sotto la copertura della scatola dei fusibili a sinistra sulla plancia si trova il dispositivo alternativo di disinserimento alto voltaggio. Esso è contrassegnato con una targhetta indicativa.

ⓘ Avvertenza
Il dispositivo alternativo di disinserimento alto voltaggio va utilizzato solo se non è possibile accedere al dispositivo di disinserimento alto voltaggio nel bagagliaio.



Targhetta indicativa dispositivo alternativo di disinserimento alto voltaggio

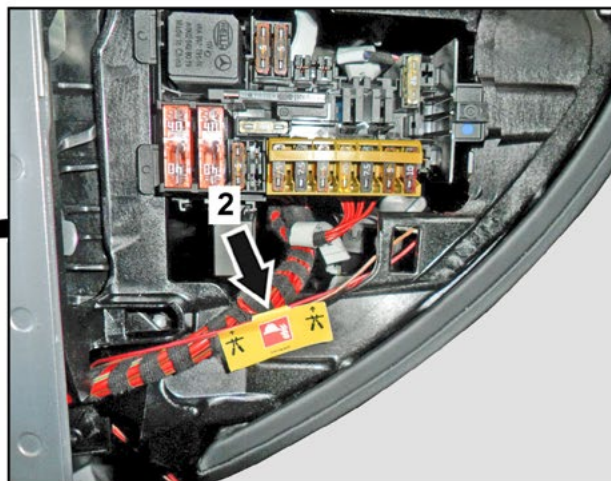
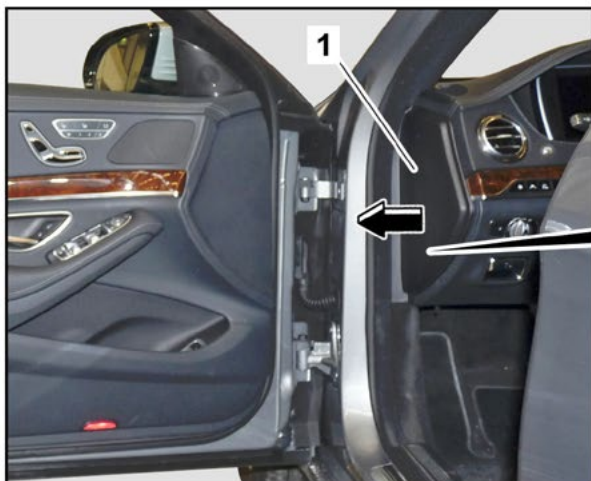

Rimuovere la copertura (1) della scatola dei fusibili / Tagliare il cavo nel punto evidenziato (2)



Mercedes-Benz

Classe S HYBRID berlina
tipo 222
a partire da 2013



Identificazione veicolo



Parafango destro

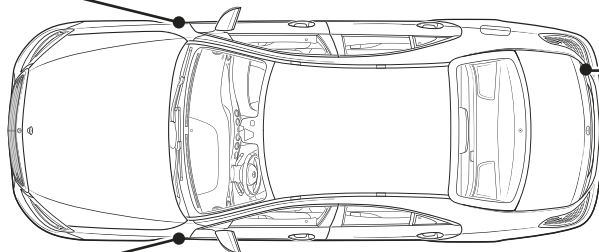

Cofano bagagli lato destro



Parafango sinistro







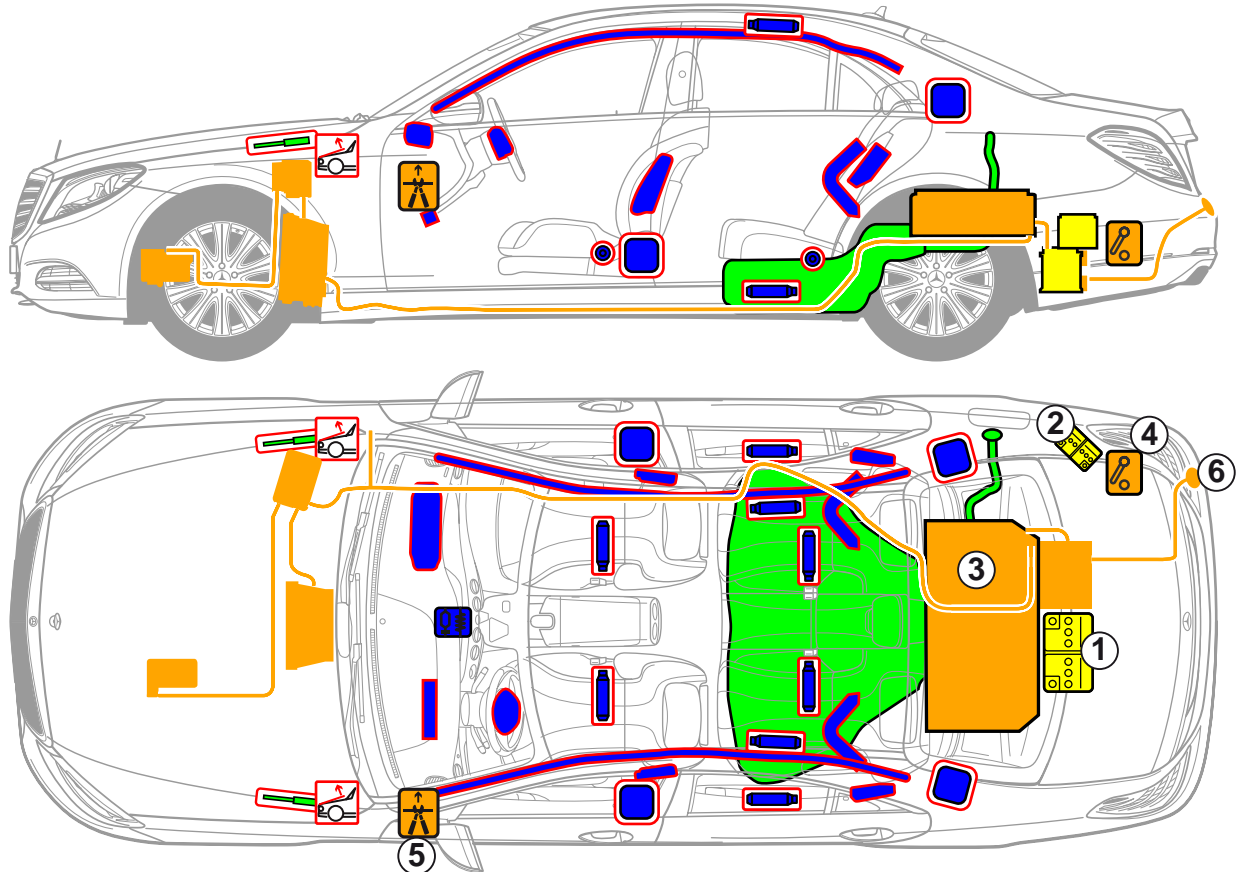







Mercedes-Benz

Classe S HYBRID PLUS (Plug-In-Hybrid) berlina tipo 222 a partire da 2013



- 1 Batteria principale (12 V)
- 2 Batteria supplementare (12 V)
- 3 Batteria ad alto voltaggio
- 4 Dispositivo di disinserimento alto voltaggio
- 5 Dispositivo alternativo di disinserimento alto voltaggio
- 6 Presa di carica di alto voltaggio

ⓘ Avvertenza
 Il dispositivo alternativo di disinserimento alto voltaggio va utilizzato solo se non è possibile accedere al dispositivo di disinserimento alto voltaggio nel bagagliaio.

 Airbag	 Generatore di gas	 Pretensionatore	 Gurtbag
 Centralina di comando sistemi di ritenuta	 Ammortizzatore pneumatico	 Protezione pedoni	 Serbatoio carburante
 Batteria 12 V	 Batteria ad alto voltaggio	 Componenti per l'alto voltaggio	 Dispositivo di disinserimento alto voltaggio
 Dispositivo alternativo di disinserimento alto voltaggio			



Dispositivo di disinserimento alto voltaggio

Sotto la copertura della cavità del bagagliaio nella parte posteriore destra si trova il dispositivo di disinserimento alto voltaggio.

Il rivestimento della cavità viene tirato fuori dal bagagliaio tramite la linguetta di trazione al di sotto del bordo di carico al centro del veicolo. La linguetta di trazione è contrassegnata tramite il simbolo .

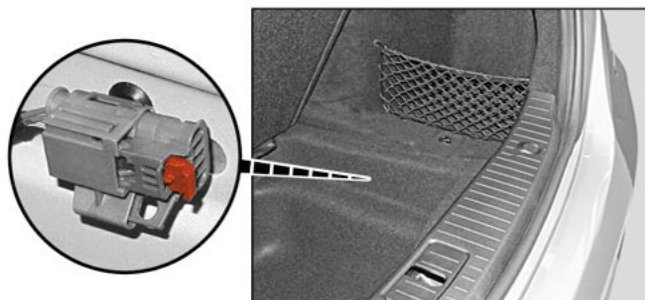

Dispositivo di disinserimento alto voltaggio nel bagagliaio

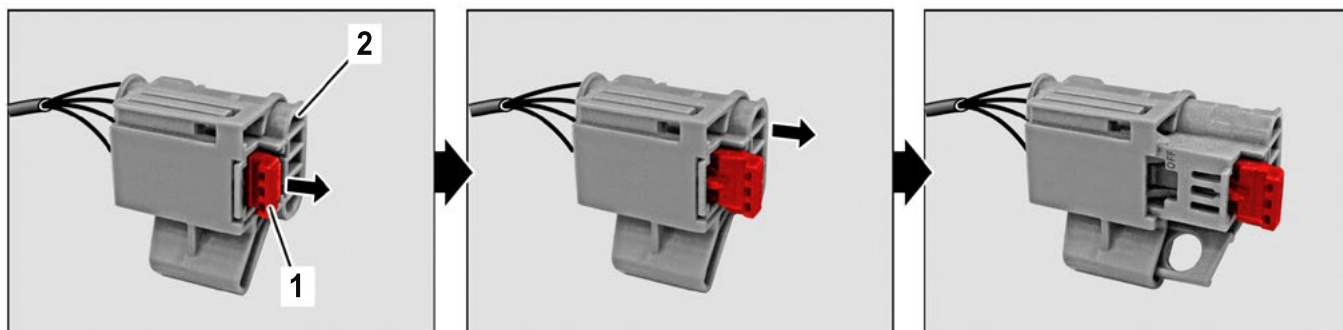

Tirare lo sbloccaggio (1) / Estrarre l'interruttore (2)

Dispositivo alternativo di disinserimento alto voltaggio

Sotto la copertura della scatola dei fusibili a sinistra sulla plancia si trova il dispositivo alternativo di disinserimento alto voltaggio. Esso è contrassegnato con una targhetta indicativa.



Targhetta indicativa dispositivo alternativo di disinserimento alto voltaggio

Avvertenza

Il dispositivo alternativo di disinserimento alto voltaggio va utilizzato solo se non è possibile accedere al dispositivo di disinserimento alto voltaggio nel bagagliaio.

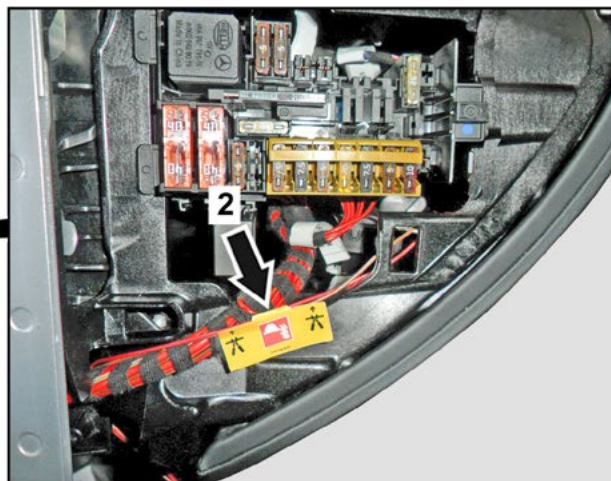
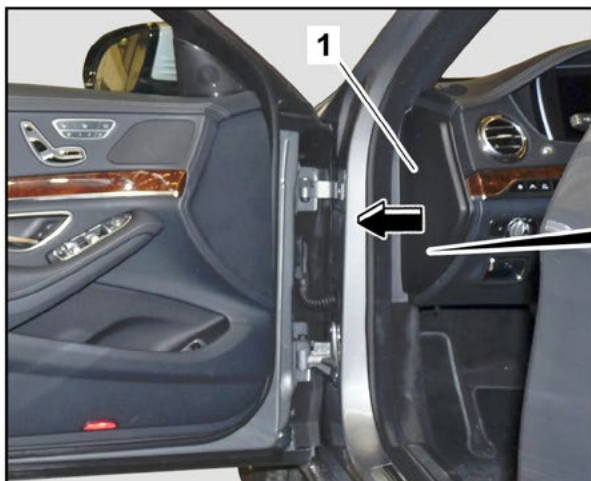

Rimuovere la copertura (1) della scatola dei fusibili / Tagliare il cavo nel punto evidenziato (2)



Mercedes-Benz

Classe S HYBRID PLUS (Plug-In-Hybrid) berlina
tipo 222
a partire da 2013



Identificazione veicolo



Parafango destro



Parafango sinistro

Cofano bagagli lato destro



Presa di carica di alto voltaggio

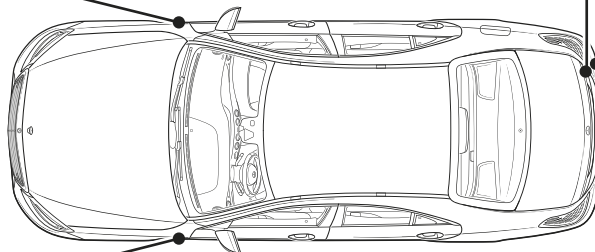



Mercedes-Benz

Classe C station-wagon
tipo 202
1996 - 2001

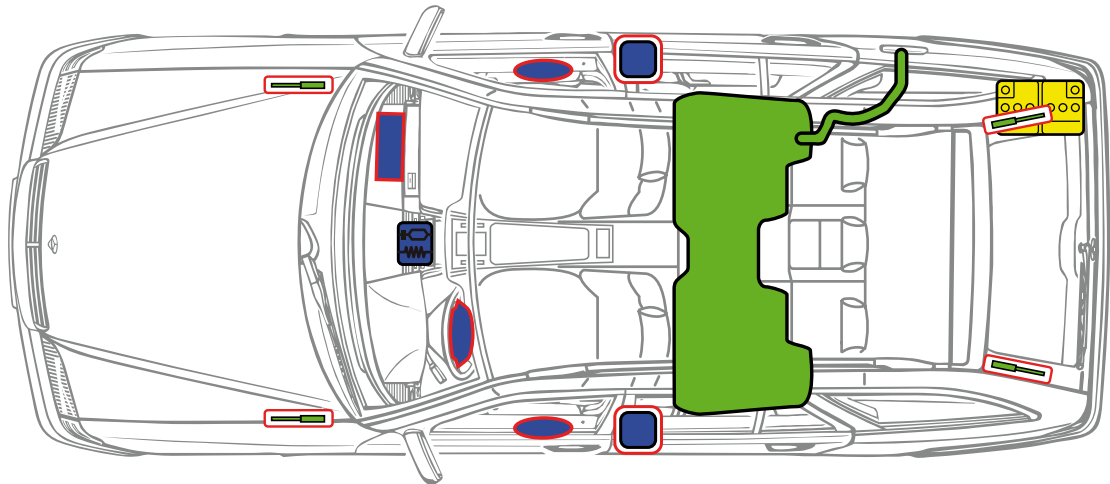
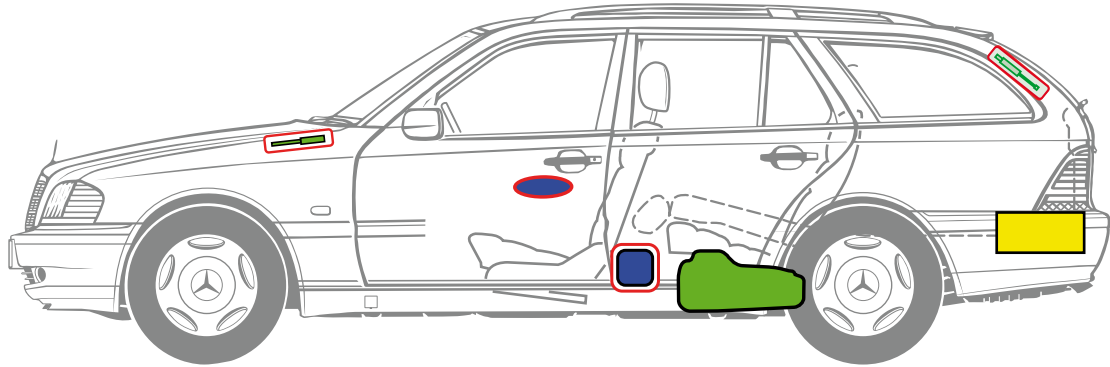

Airbag

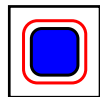

Pretensionatore



Centralina di comando
sistemi di ritenuta



Ammortizzatore
pneumatico



Serbatoio carburante

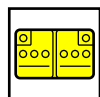

Batteria



Mercedes-Benz

Classe C station-wagon
tipo 203
2001 - 2007

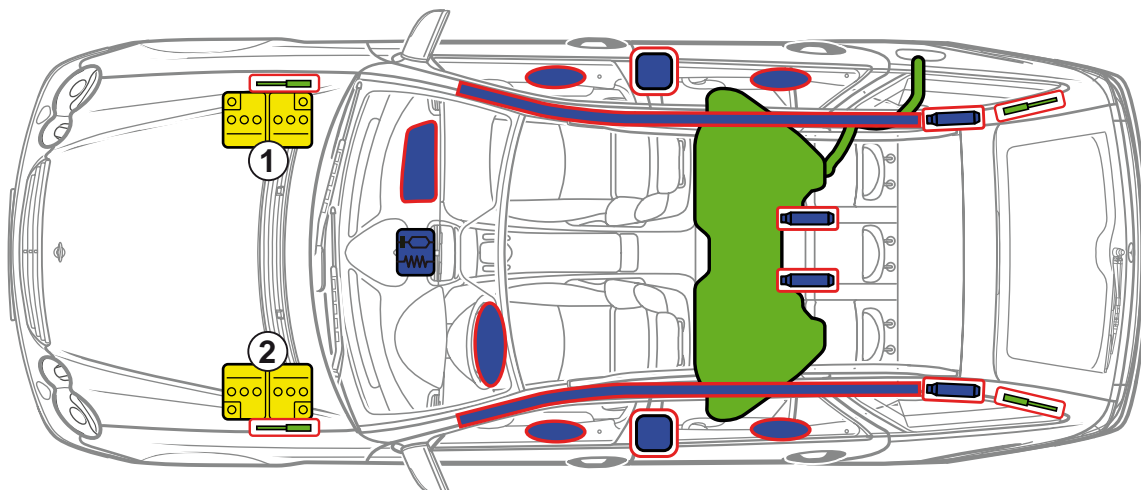
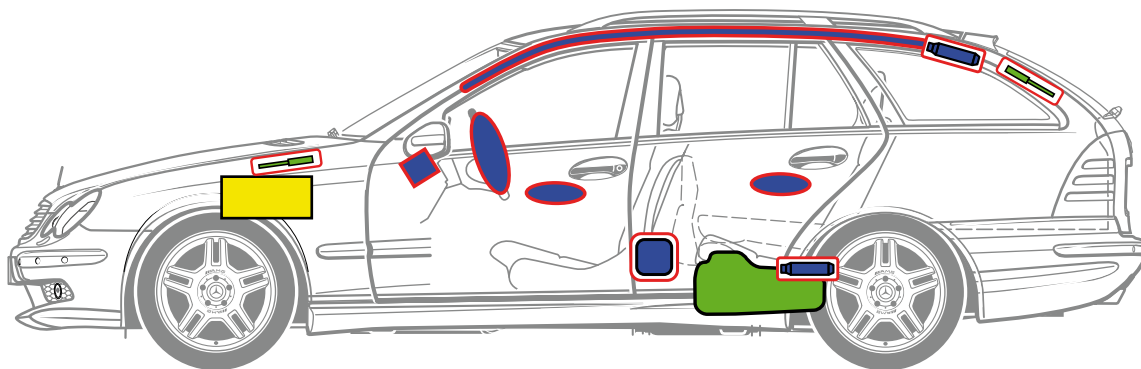
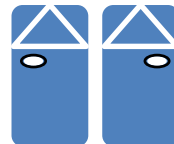

- 1 Veicolo con guida a sinistra
- 2 Veicolo con guida a destra

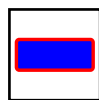

Airbag

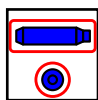

Generatore di gas

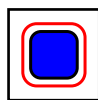

Pretensionatore

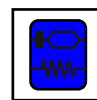

Centralina di comando sistemi di ritenuta



Ammortizzatore pneumatico



Serbatoio carburante



Batteria



Mercedes-Benz

Classe C station-wagon tipo 204 a partire da 2007

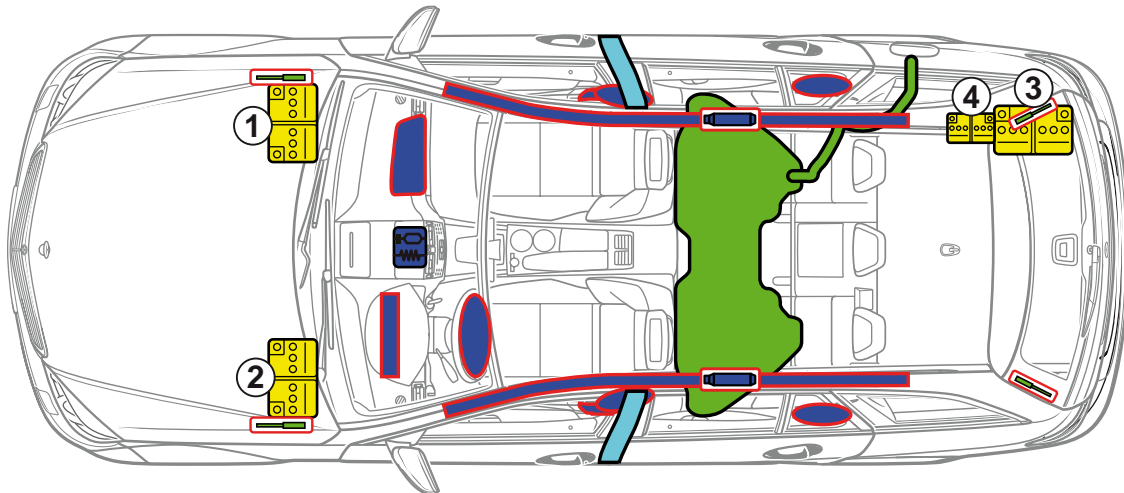
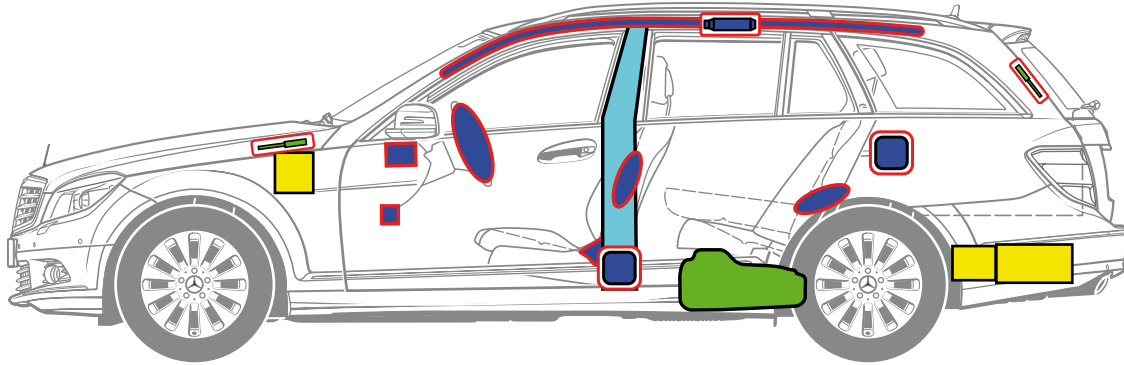
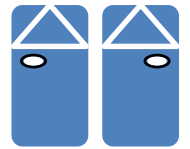

- 1 Batteria rete di bordo in caso di motore a benzina, a partire da 1.12.2009 in caso di motore diesel a 4 o 8 cilindri e AMG, veicolo con guida a sinistra
- 2 Batteria rete di bordo in caso di motore a benzina, a partire da 1.12.2009 in caso di motore diesel a 4 o 8 cilindri e AMG, veicolo con guida a destra
- 3 Batteria rete di bordo in caso di motore diesel a 6 cilindri, fino a 30.11.2009 in caso di motore diesel a 4 o 8 cilindri e AMG
- 4 Batteria supplementare ECO start/stop

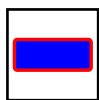

Airbag

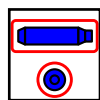

Generatore di gas

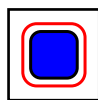

Pretensionatore

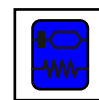

Centralina di comando sistemi di ritenuta



Ammortizzatore pneumatico

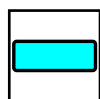

Rinforzo carrozzeria



Serbatoio carburante



Batteria



Mercedes-Benz

Classe E station-wagon tipo 123 1977 - 1986

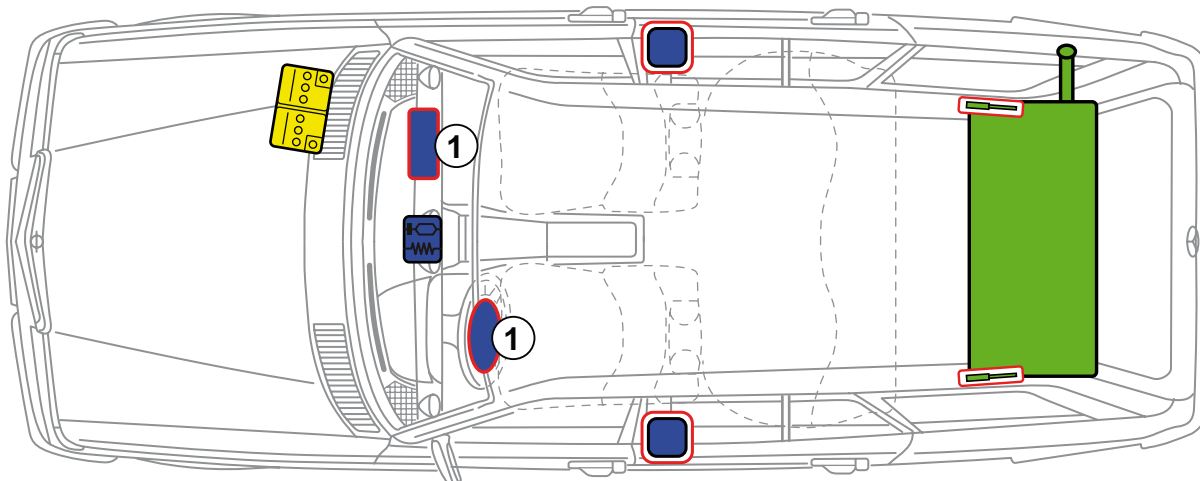
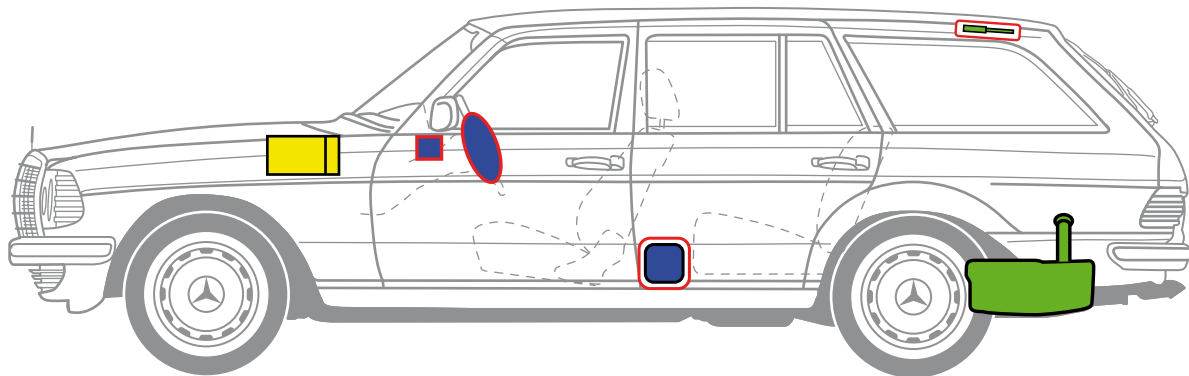

1 A partire da 1980



Airbag

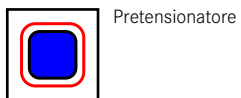

Pretensionatore

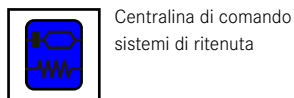

Centralina di comando sistemi di ritenuta

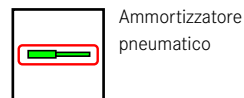

Ammortizzatore pneumatico



Serbatoio carburante

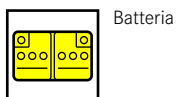

Batteria



Mercedes-Benz

Classe E station-wagon
tipo 124
1984 - 1996

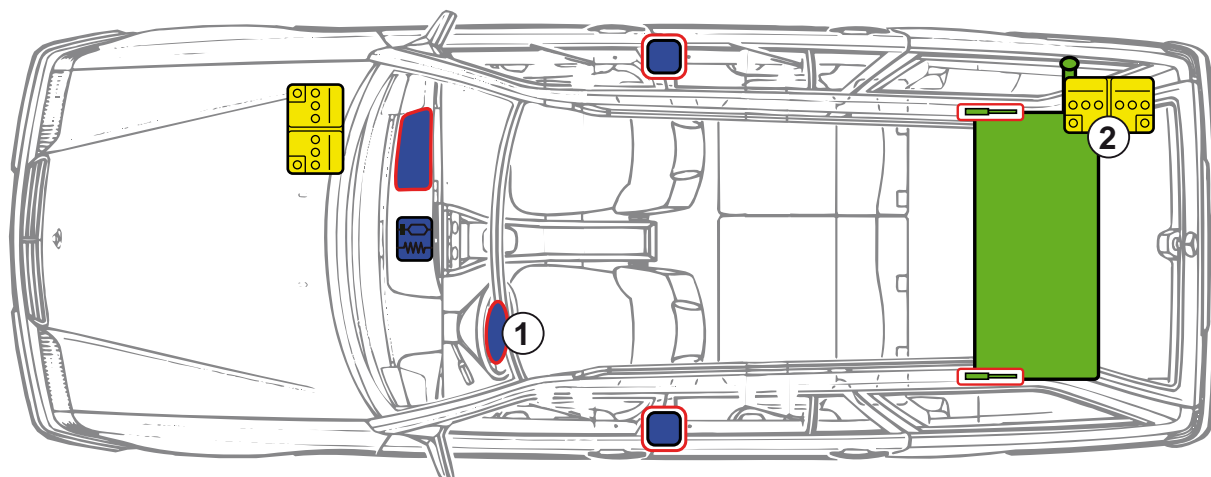
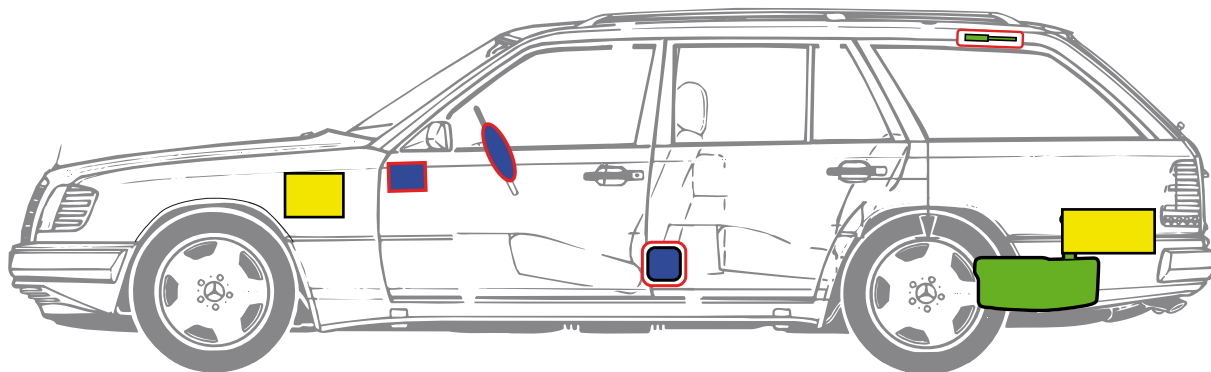

- 1 A partire da 1992 di serie
- 2 Batteria nel bagagliaio in caso di motore a 8 cilindri



Airbag

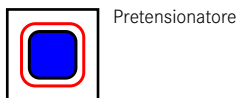

Pretensionatore

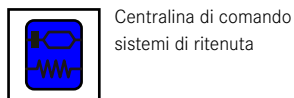

Centralina di comando sistemi di ritenuta

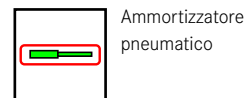

Ammortizzatore pneumatico



Serbatoio carburante

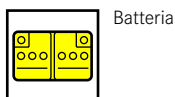

Batteria



Mercedes-Benz

Classe E station-wagon
tipo 210
1996 - 2003

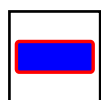
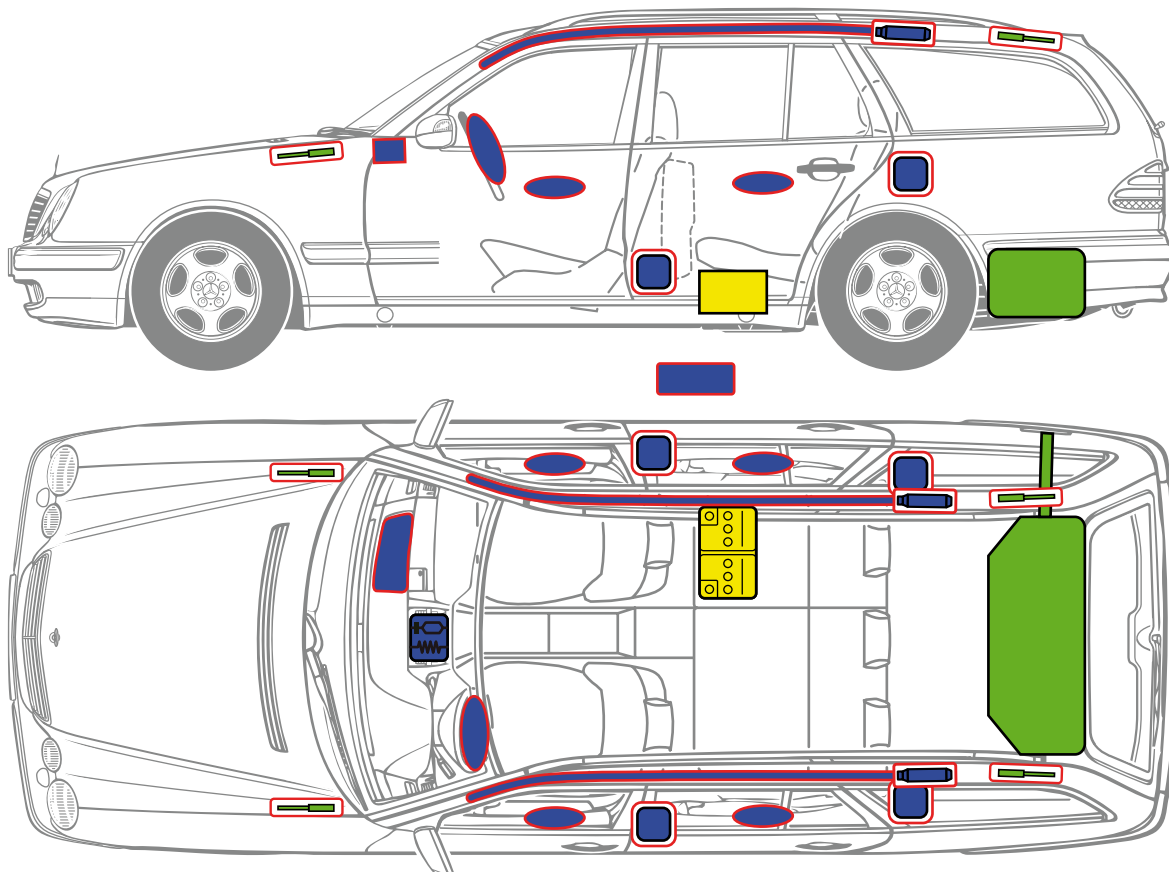

Airbag

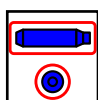

Generatore di gas

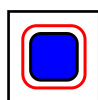

Pretensionatore

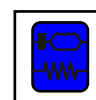

Centralina di comando
sistemi di ritenuta

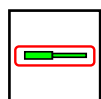

Ammortizzatore
pneumatico



Serbatoio carburante



Batteria



Mercedes-Benz

Classe E station-wagon
tipo 211
2003 - 2009

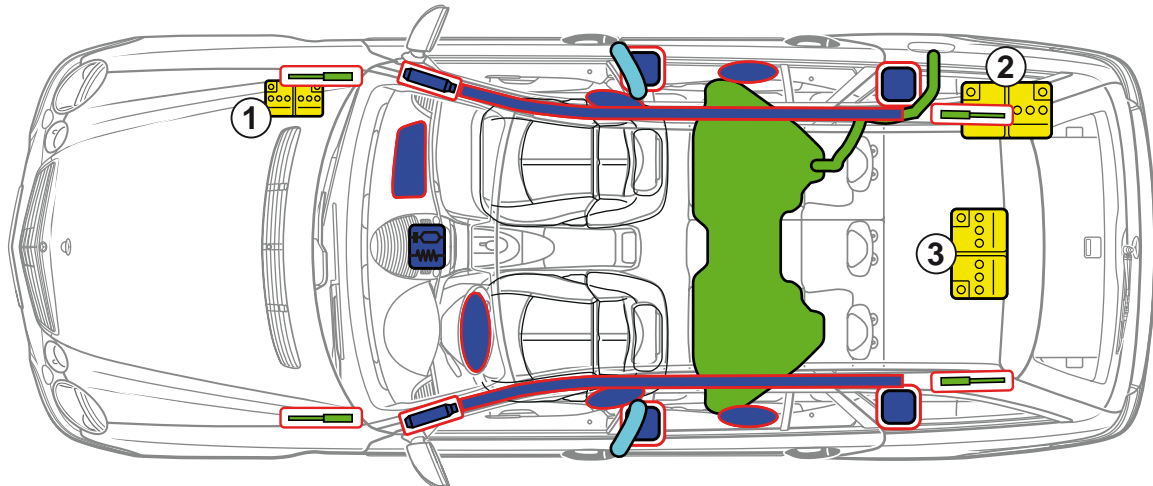
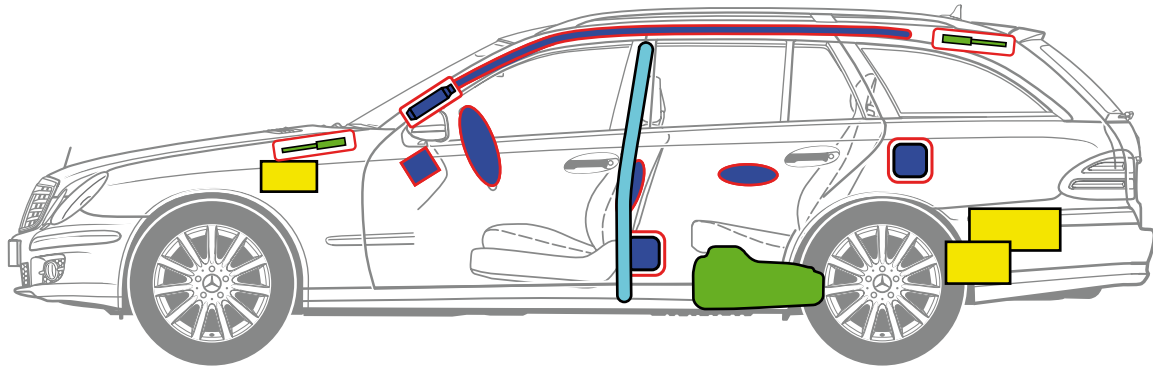

- 1 Batteria supplementare vano motore (fino a 31.05.2006)
- 2 Batteria principale bagagliaio (in caso di equipaggiamento con ruota di scorta)
- 3 Batteria principale bagagliaio (in caso di equipaggiamento senza ruota di scorta)

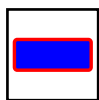

Airbag

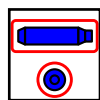

Generatore di gas

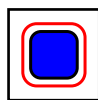

Pretensionatore

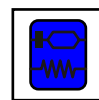

Centralina di comando sistemi di ritenuta



Ammortizzatore pneumatico

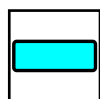

Rinforzo carrozzeria



Serbatoio carburante



Batteria



Mercedes-Benz

Classe E station-wagon
tipo 212
2009 - 2012

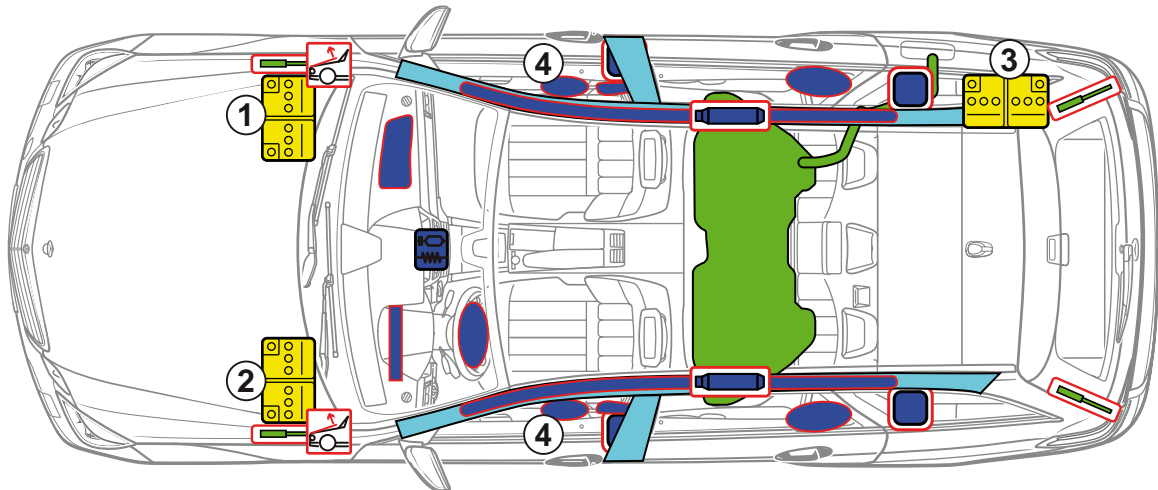
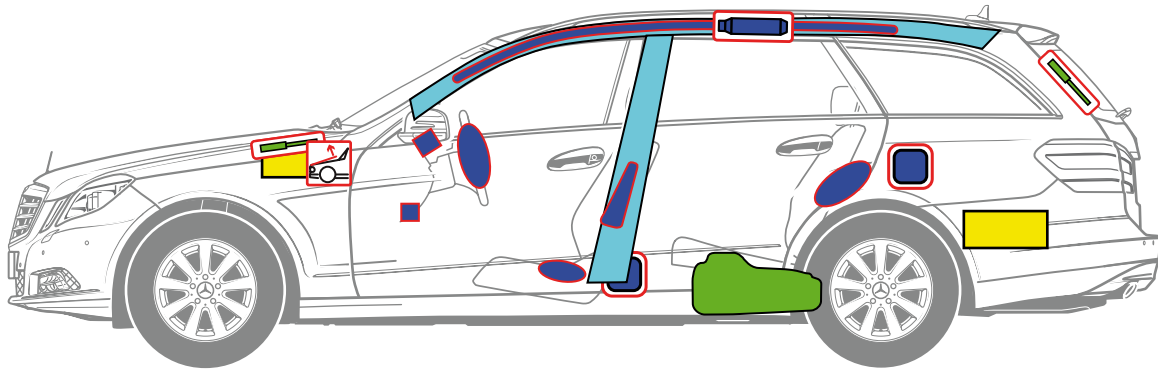
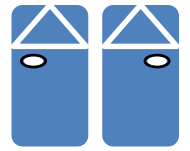

- 1 Veicolo con guida a sinistra, in caso di motore a 4 o 6 cilindri, motore a 8 cilindri a partire dall'anno di produzione 2011
- 2 Veicolo con guida a destra, in caso di motore a 4 o 6 cilindri, motore a 8 cilindri a partire dall'anno di produzione 2011
- 3 In caso di motore a 8 cilindri (fino all'anno di produzione 2011)
- 4 Airbag per il bacino (a partire da 06.2009)

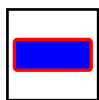

Airbag

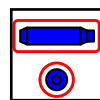

Generatore di gas

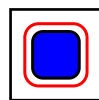

Pretensionatore

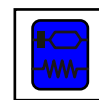

Centralina di comando sistemi di ritenuta



Protezione pedoni

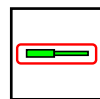

Ammortizzatore pneumatico



Rinforzo carrozzeria



Serbatoio carburante

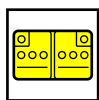

Batteria



Mercedes-Benz

Classe E HYBRID station-wagon tipo 212 a partire da 2012

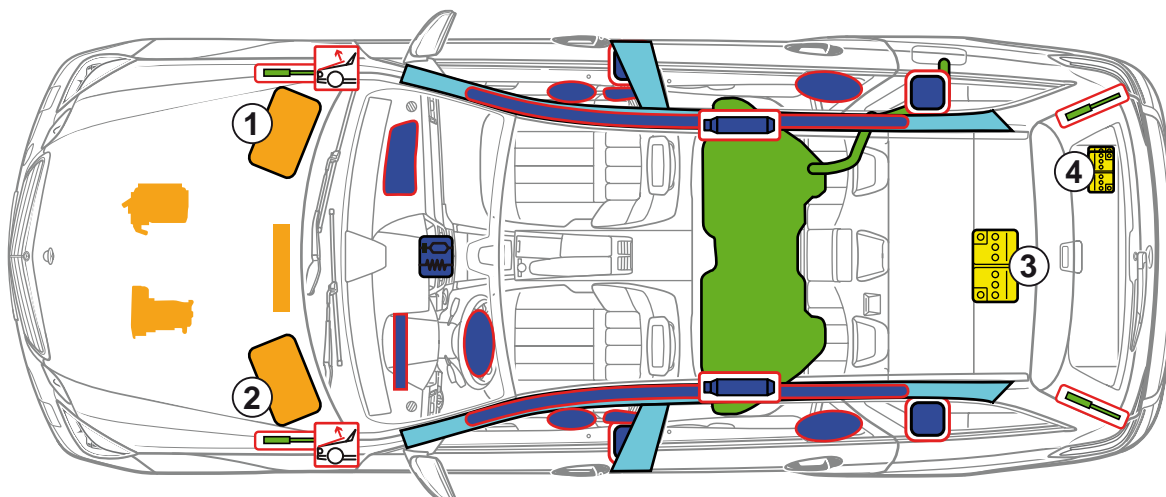
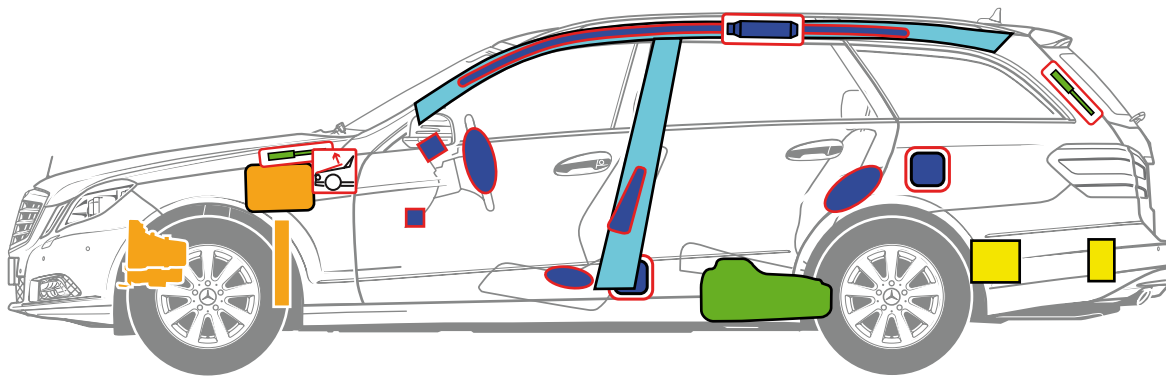
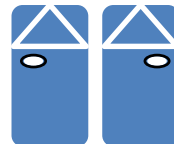

- 1 Batteria ad alto voltaggio, veicolo con guida a sinistra
- 2 Batteria ad alto voltaggio, veicolo con guida a destra
- 3 Batteria rete di bordo
- 4 Batteria supplementare (opzionale)

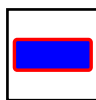

Airbag

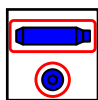

Generatore di gas

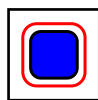

Pretensionatore

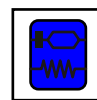

Centralina di comando sistemi di ritenuta



Protezione pedoni



Ammortizzatore pneumatico



Rinforzo carrozzeria



Serbatoio carburante

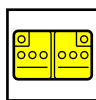

Batteria 12 V

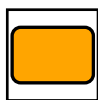

Batteria ad alto voltaggio



Componenti per l'alto voltaggio



Mercedes-Benz

Classe E HYBRID station-wagon
tipo 212
a partire da 2012



Identificazione veicolo



Parafango destro



Parafango sinistro

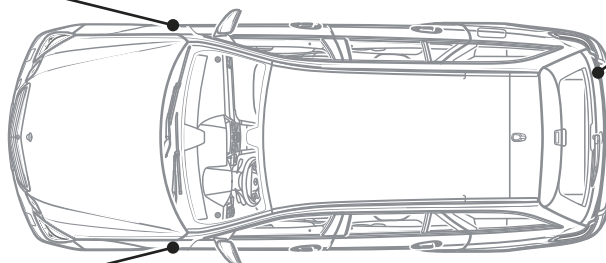

Portellone posteriore lato destro





Mercedes-Benz

Classe E station-wagon anno di produzione 2014
tipo 212
a partire da 2013

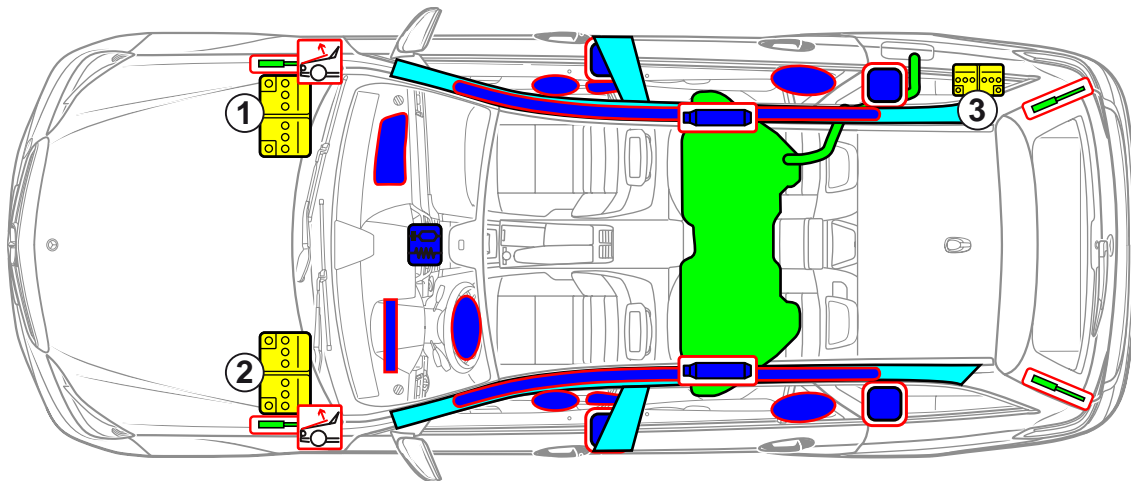
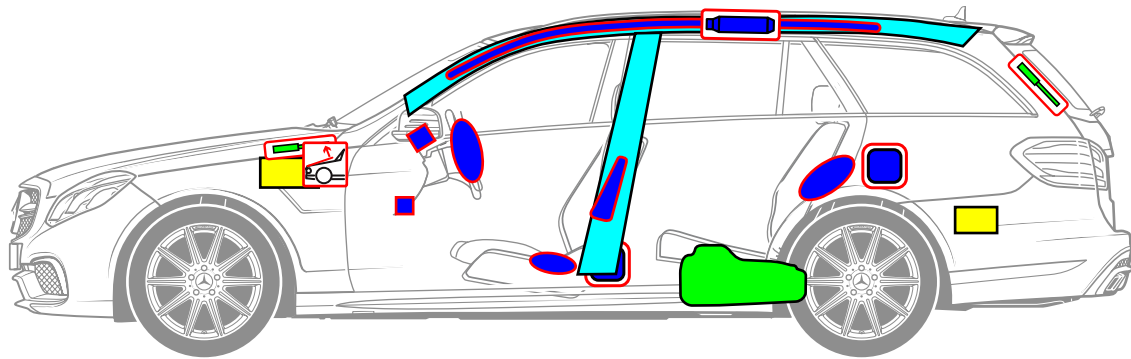
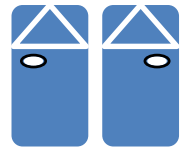

- 1 Veicolo con guida a sinistra
- 2 Veicolo con guida a destra
- 3 Batteria supplementare (opzionale)

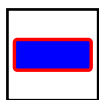

Airbag

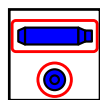

Generatore di gas

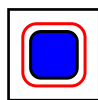

Pretensionatore

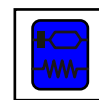

Centralina di comando sistemi di ritenuta



Protezione pedoni

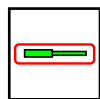

Ammortizzatore pneumatico



Rinforzo carrozzeria



Serbatoio carburante

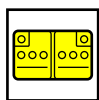

Batteria



Mercedes-Benz

Classe B Tourer
tipo 245
2005 - 2011

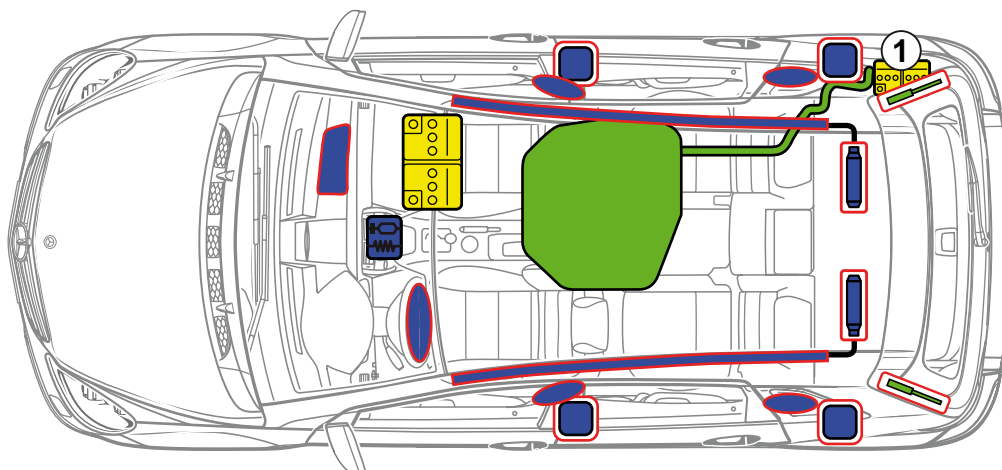
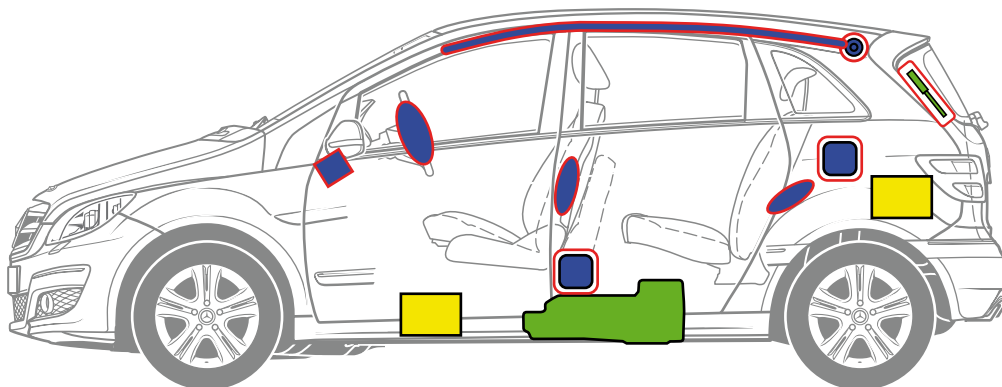

1 Batteria supplementare modelli BlueEFFICIENCY



Airbag



Generatore di gas



Pretensionatore



Centralina di comando sistemi di ritenuta

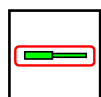

Ammortizzatore pneumatico



Serbatoio carburante



Batteria



Mercedes-Benz

Classe B F-CELL Tourer
tipo 245
a partire da 2010

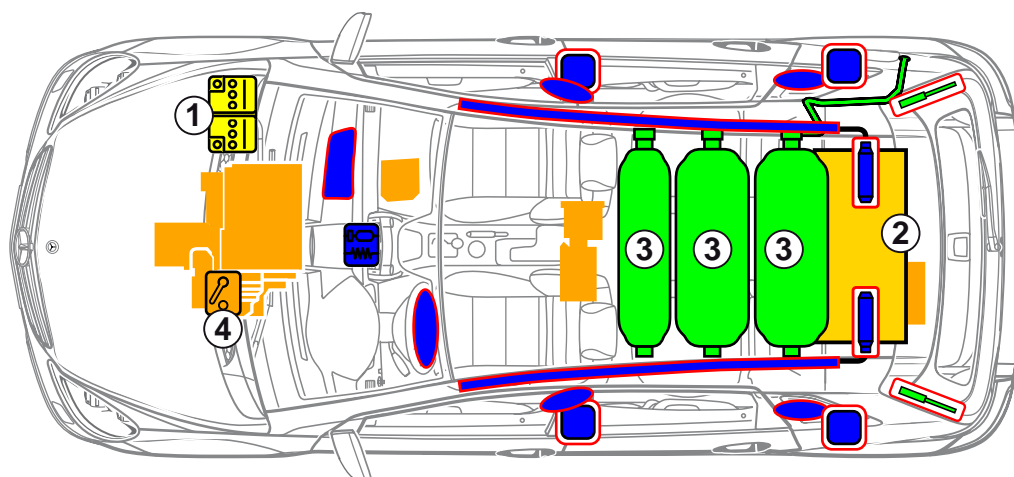
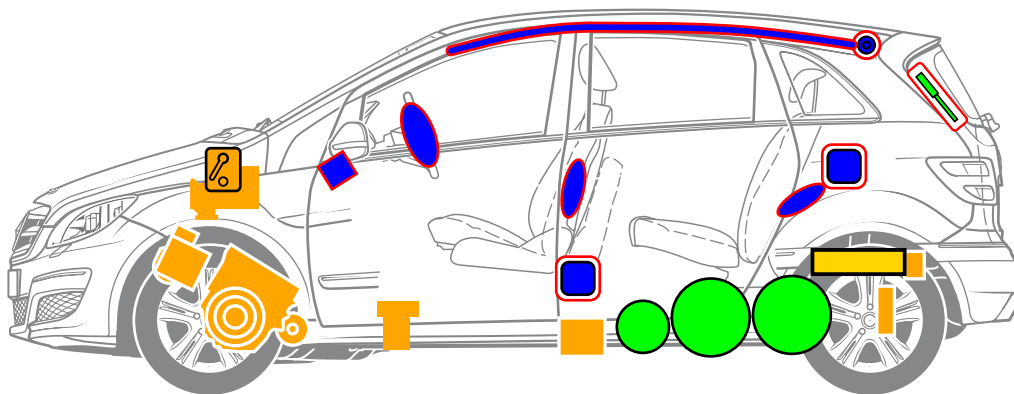

- 1 Batteria (12 V)
- 2 Batteria ad alto voltaggio
- 3 Serbatoio di idrogeno
- 4 Dispositivo di disinserimento alto voltaggio

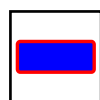

Airbag

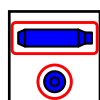

Generatore di gas

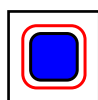

Pretensionatore

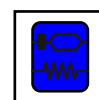

Centralina di comando sistemi di ritenuta



Ammortizzatore pneumatico

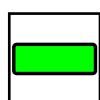

Serbatoio carburante

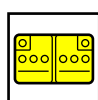

Batteria 12 V



Batteria ad alto voltaggio



Componenti per l'alto voltaggio



Dispositivo di disinserimento alto voltaggio



Sistema ad alto voltaggio

Tutti i componenti ad alto voltaggio sono contrassegnati tramite un corrispondente adesivo di avvertimento.
I cavi per alto voltaggio sono di colore arancione



Adesivo di avvertimento alto voltaggio

Sistema di idrogeno

I componenti del sistema di idrogeno sono muniti di un corrispondente adesivo di avvertimento, anche le due tubazioni di idrogeno tra la cella a combustibile e il modulo anodico.



Adesivo di avvertimento idrogeno

Dispositivo di disinserimento alto voltaggio

Il dispositivo di disinserimento alto voltaggio si trova in alto sul compressore del fluido refrigerante (3) nel vano motore in direzione di marcia a sinistra.

Tirare in alto l'anello di sicurezza (1) / Staccare il connettore a spina (2)

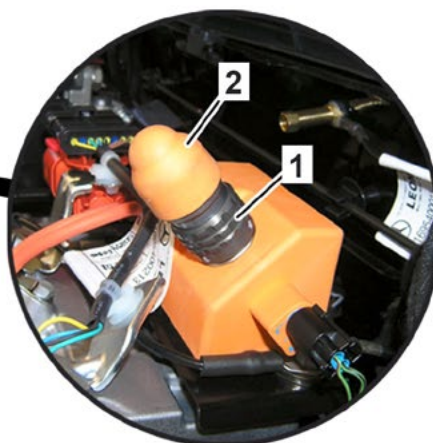



Mercedes-Benz

Classe B F-CELL Tourer
tipo 245
a partire da 2010



Identificazione veicolo



Bocchettone di rifornimento idrogeno (H₂)

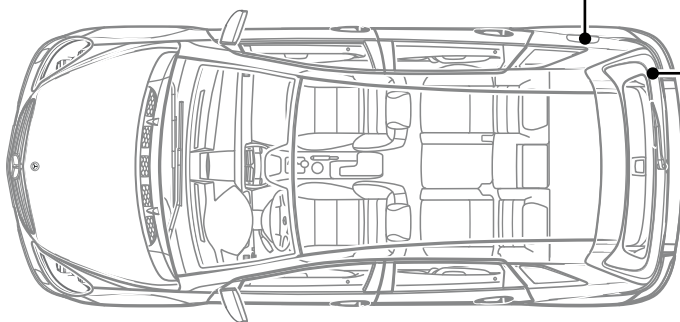

Portellone posteriore lato destro



Mercedes-Benz

Classe B NGT Tourer
tipo 245
2005 - 2012

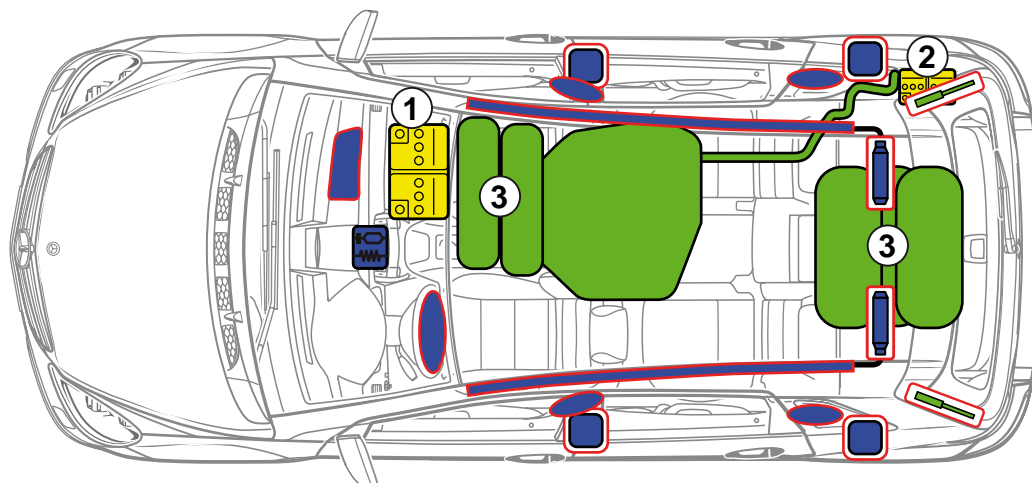
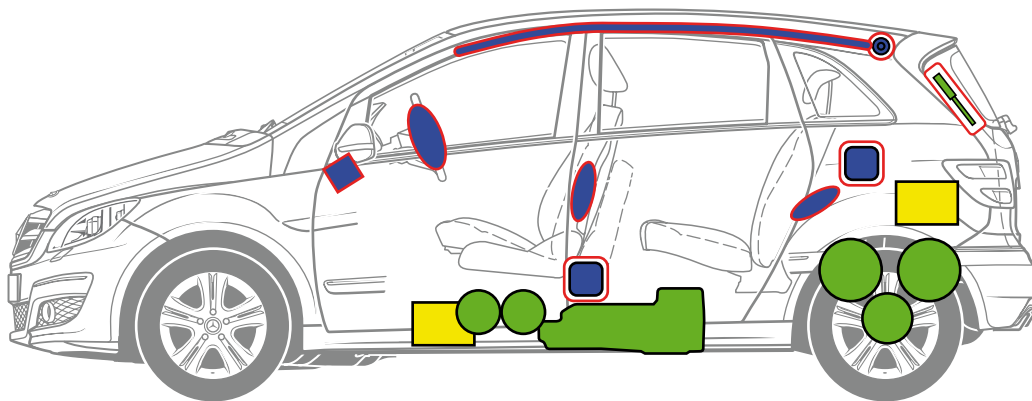

- 1 Batteria principale
- 2 Batteria supplementare modelli BlueEFFICIENCY
- 3 Serbatoio gas



Airbag

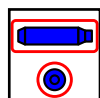

Generatore di gas



Pretensionatore



Centralina di comando sistemi di ritenuta

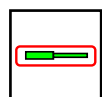

Ammortizzatore pneumatico

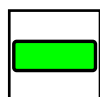

Serbatoio carburante



Batteria



Mercedes-Benz

Classe B NGT Tourer
tipo 245
2005 - 2012



Identificazione veicolo

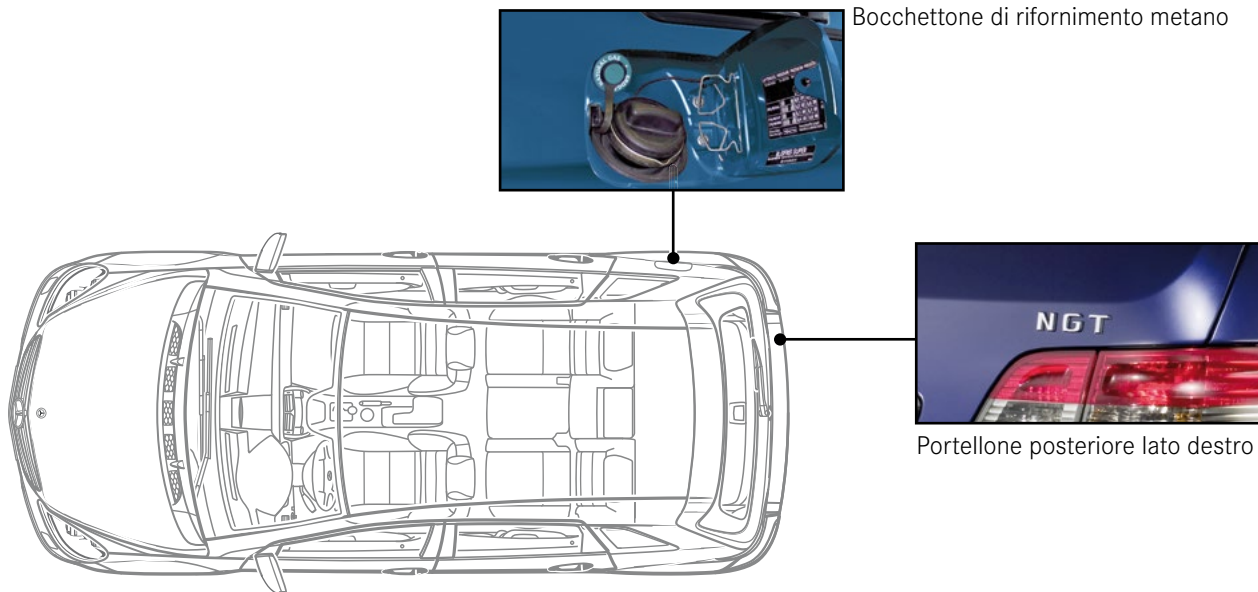



Mercedes-Benz

Classe B Tourer tipo 246 a partire da 2011

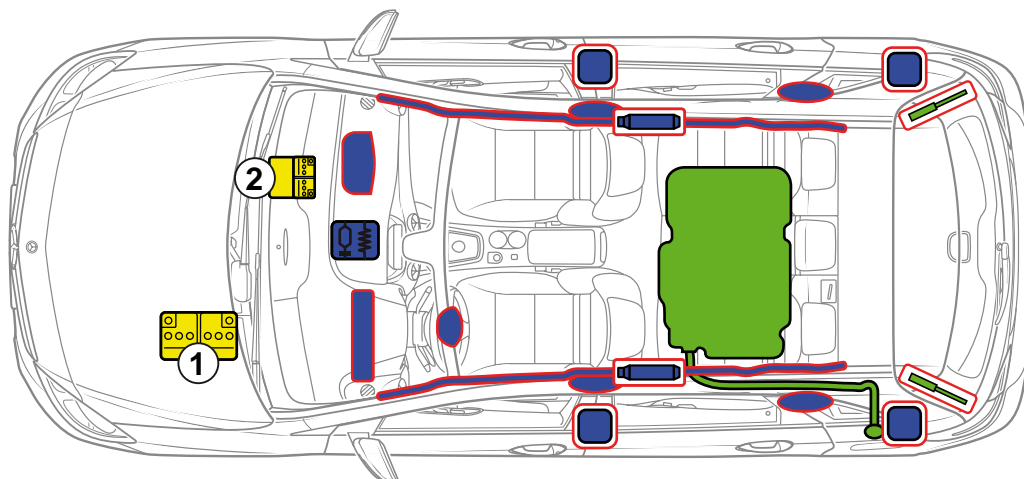
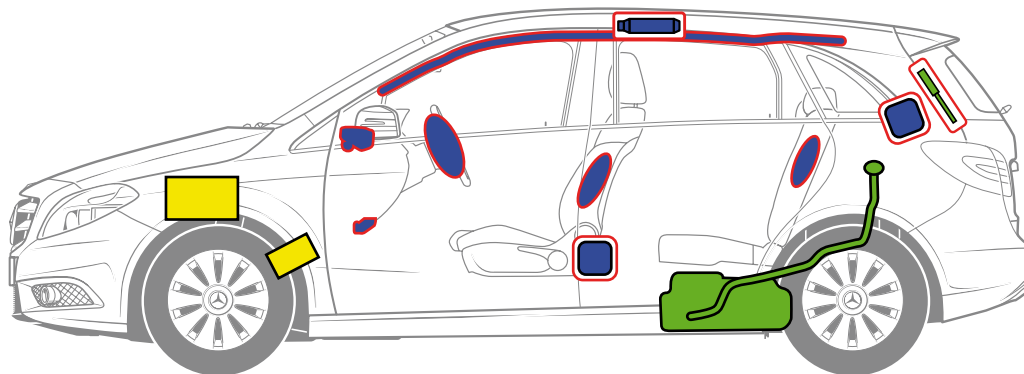

- 1 Batteria rete di bordo
- 2 Batteria supplementare ECO start/stop

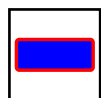

Airbag



Generatore di gas



Pretensionatore



Centralina di comando sistemi di ritenuta

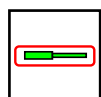

Ammortizzatore pneumatico



Serbatoio carburante



Batteria



Mercedes-Benz

Classe B NATURAL GAS DRIVE Tourer tipo 242 a partire da 2013

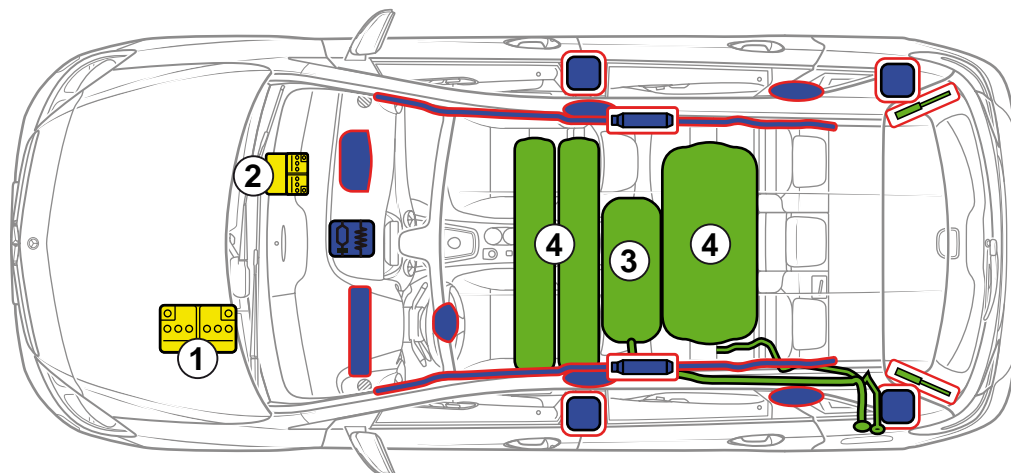
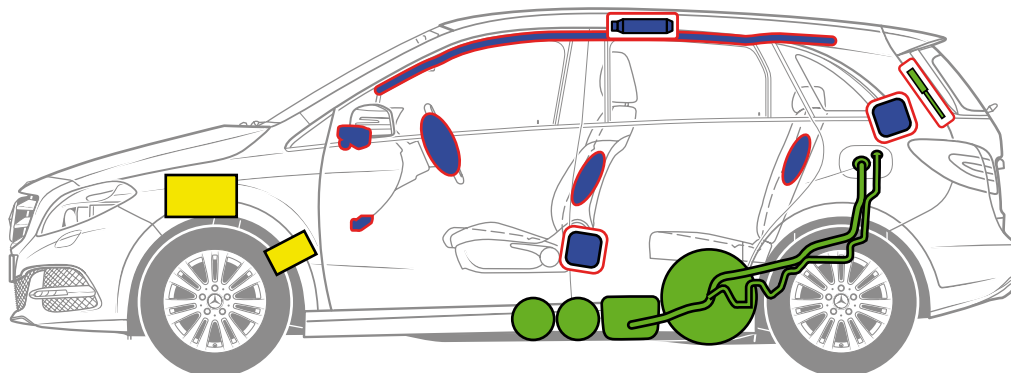

- 1 Batteria rete di bordo
- 2 Batteria supplementare ECO start/stop
- 3 Serbatoio carburante
- 4 Serbatoio gas



Airbag

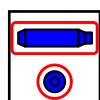

Generatore di gas

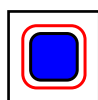

Pretensionatore

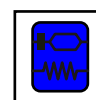

Centralina di comando sistemi di ritenuta

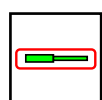

Ammortizzatore pneumatico

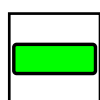

Serbatoio carburante

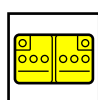

Batteria



Mercedes-Benz

Classe B NATURAL GAS DRIVE Tourer
tipo 242
a partire da 2013



Identificazione veicolo

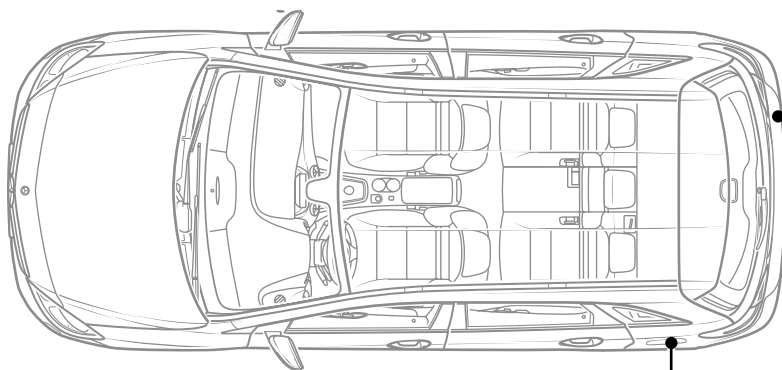

Portellone posteriore lato destro



Bocchettone di rifornimento metano



Mercedes-Benz

Classe R Tourer
tipo 251
a partire da 2005

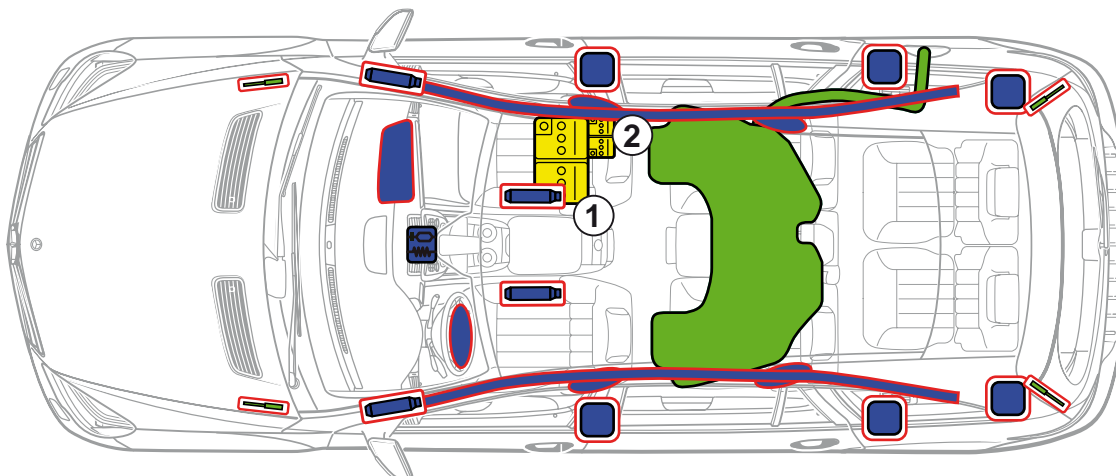
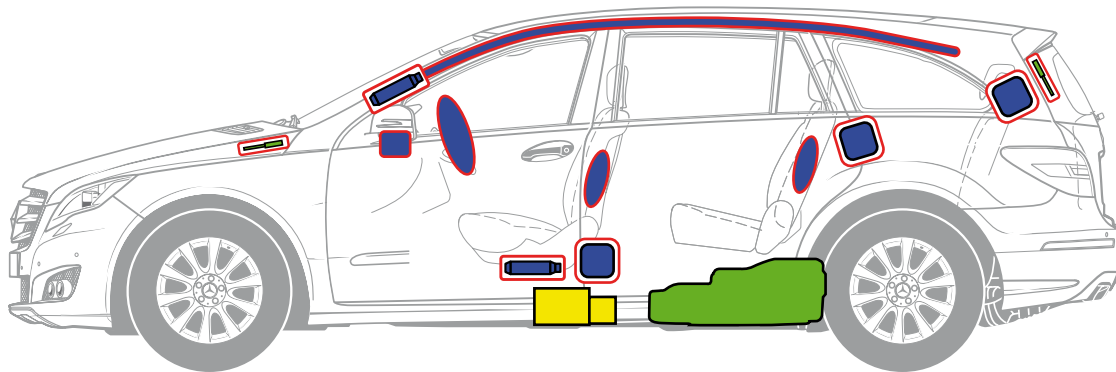

- 1 Batteria principale
- 2 Batteria supplementare



Airbag



Generatore di gas



Pretensionatore



Centralina di comando sistemi di ritenuta



Ammortizzatore pneumatico



Serbatoio carburante



Batteria



Mercedes-Benz

Classe A coupé
tipo 169
2004 - 2012

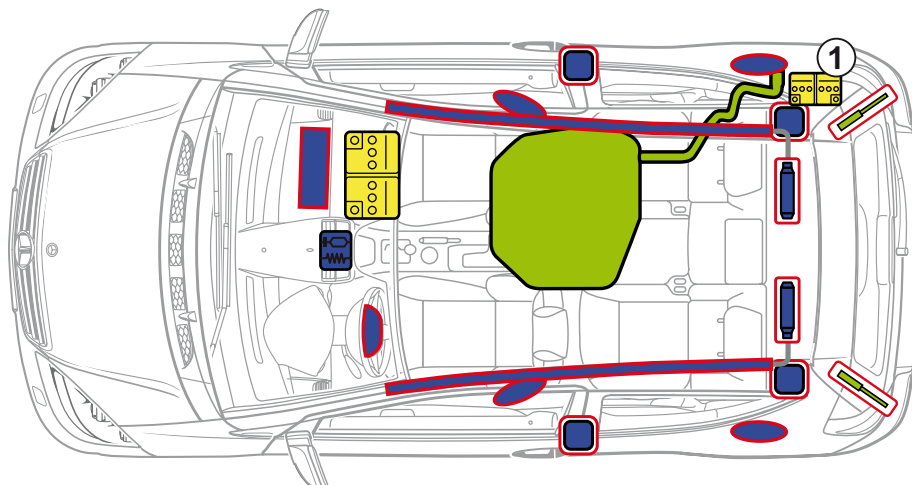
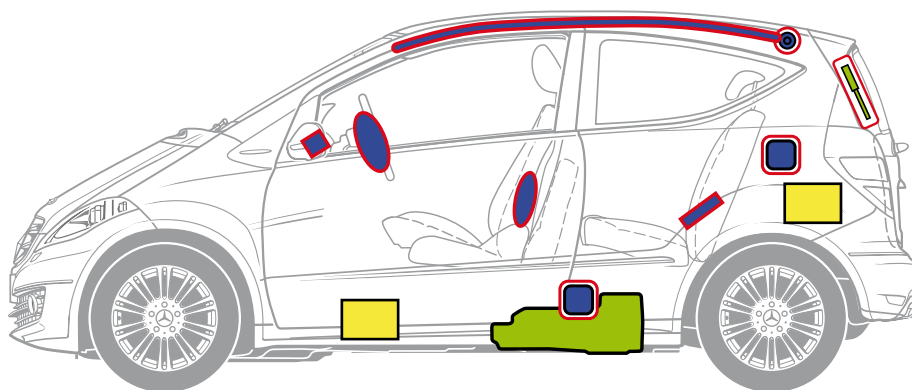

1 Batteria supplementare modelli BlueEFFICIENCY

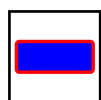

Airbag

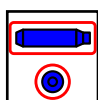

Generatore di gas

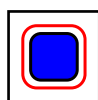

Pretensionatore

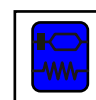

Centralina di comando sistemi di ritenuta

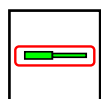

Ammortizzatore pneumatico



Serbatoio carburante



Batteria



Mercedes-Benz

Classe C Sportcoupé
tipo 203
2000 - 2008

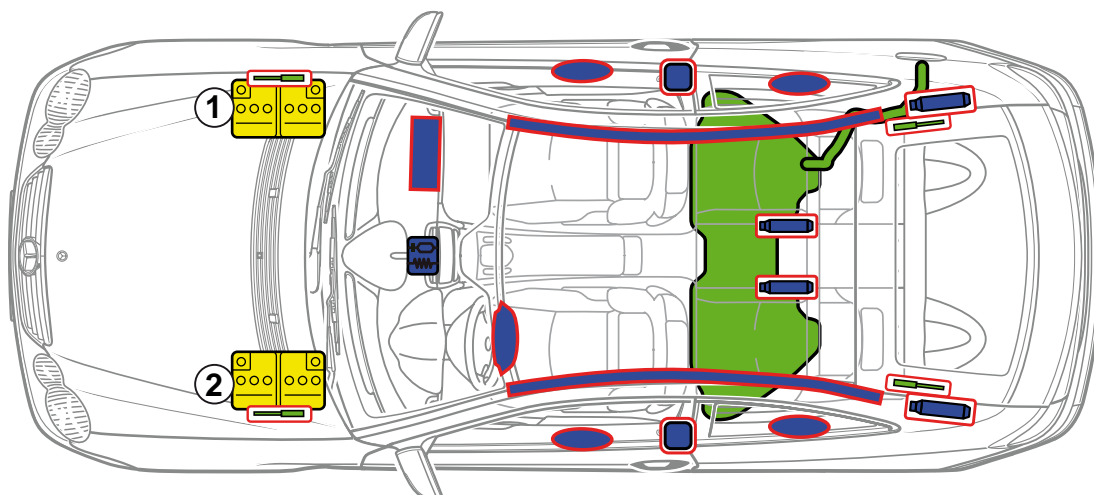
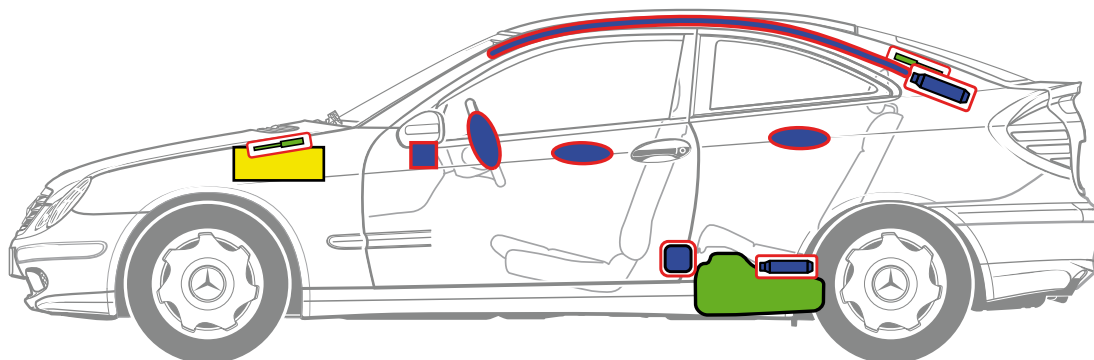
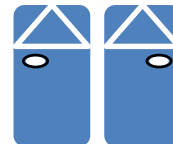

- 1 Veicolo con guida a sinistra
- 2 Veicolo con guida a destra



Airbag



Generatore di gas



Pretensionatore



Centralina di comando sistemi di ritenuta



Ammortizzatore pneumatico



Serbatoio carburante



Batteria



Mercedes-Benz

Classe C coupé
tipo 204
a partire da 2011

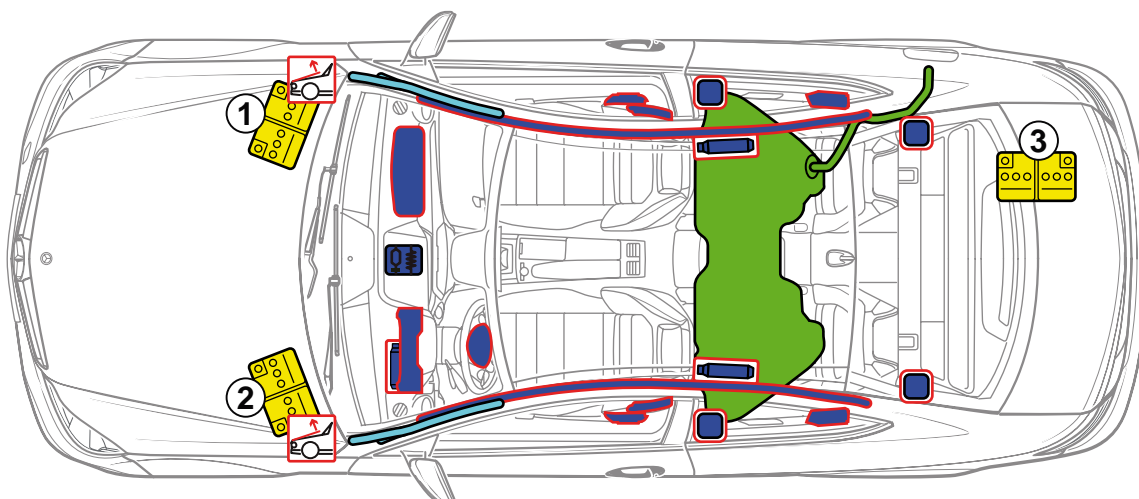
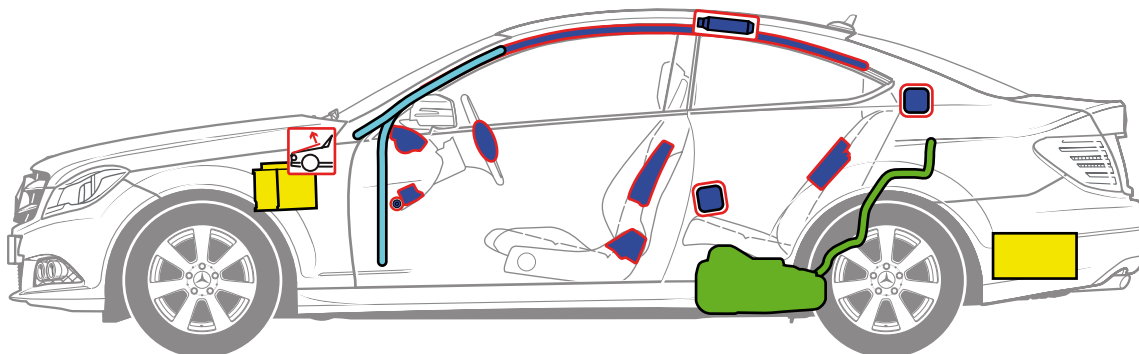
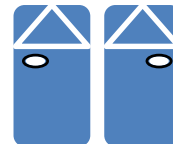

- 1 Batteria rete di bordo, veicolo con guida a sinistra
- 2 Batteria rete di bordo, veicolo con guida a destra
- 3 Batteria supplementare



Airbag



Generatore di gas



Pretensionatore



Centralina di comando sistemi di ritenuta



Ammortizzatore pneumatico



Protezione pedoni



Serbatoio carburante



Rinforzo carrozzeria



Batteria



Mercedes-Benz

Classe CLA coupé tipo 117 a partire da 2013

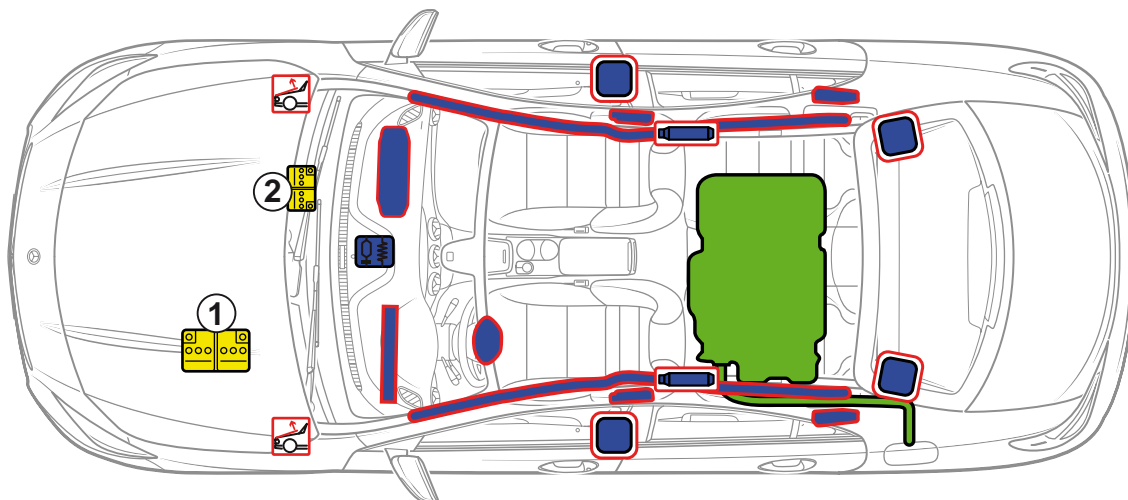
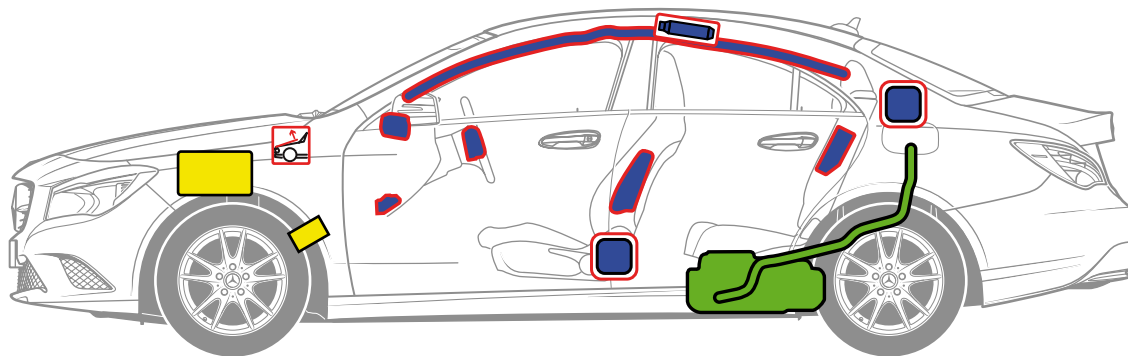

- 1 Batteria principale
- 2 Batteria supplementare



Airbag



Generatore di gas



Pretensionatore



Centralina di comando sistemi di ritenuta



Protezione pedoni



Serbatoio carburante



Batteria



Mercedes-Benz

Classe CLC coupé
tipo 203
a partire da 2008

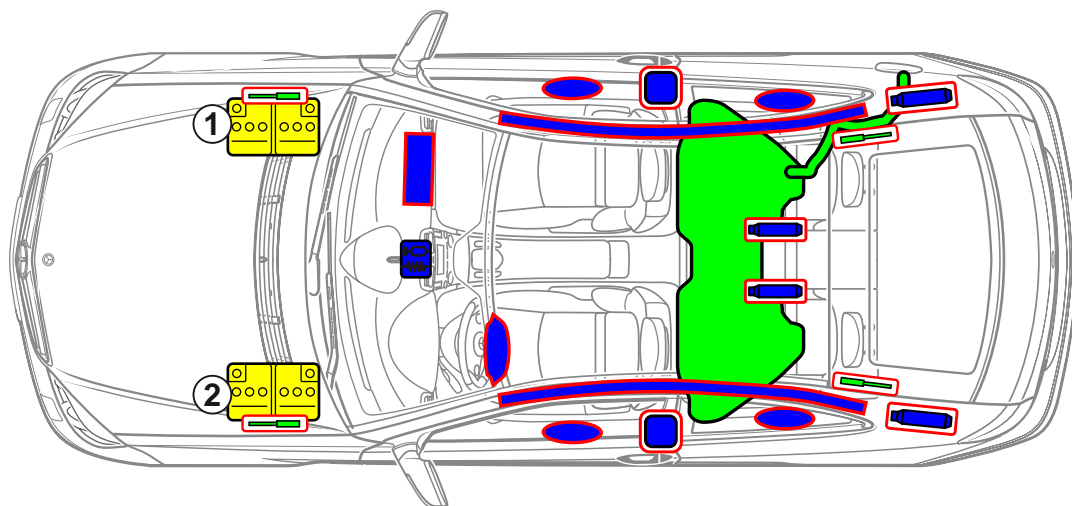
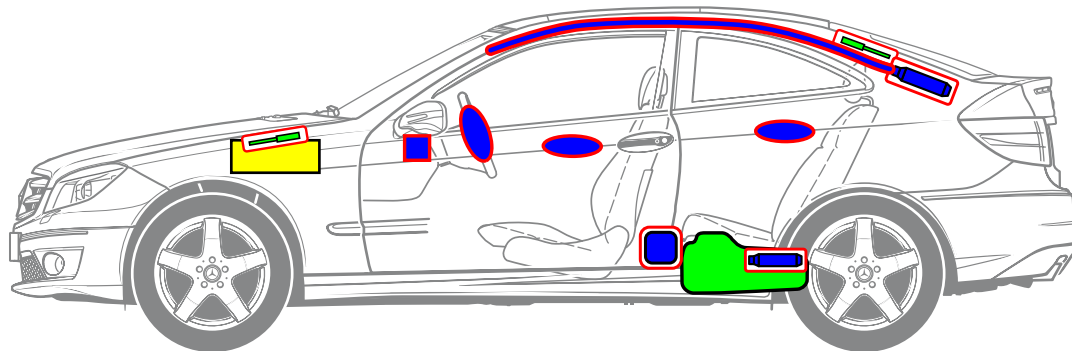
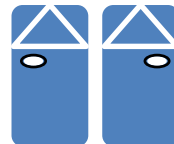

- 1 Veicolo con guida a sinistra
- 2 Veicolo con guida a destra

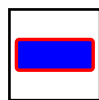

Airbag

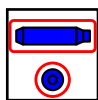

Generatore di gas

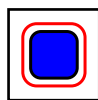

Pretensionatore

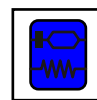

Centralina di comando
sistemi di ritenuta



Ammortizzatore
pneumatico



Serbatoio carburante



Batteria



Mercedes-Benz

Classe CLK coupé
tipo 208
1997 - 2002

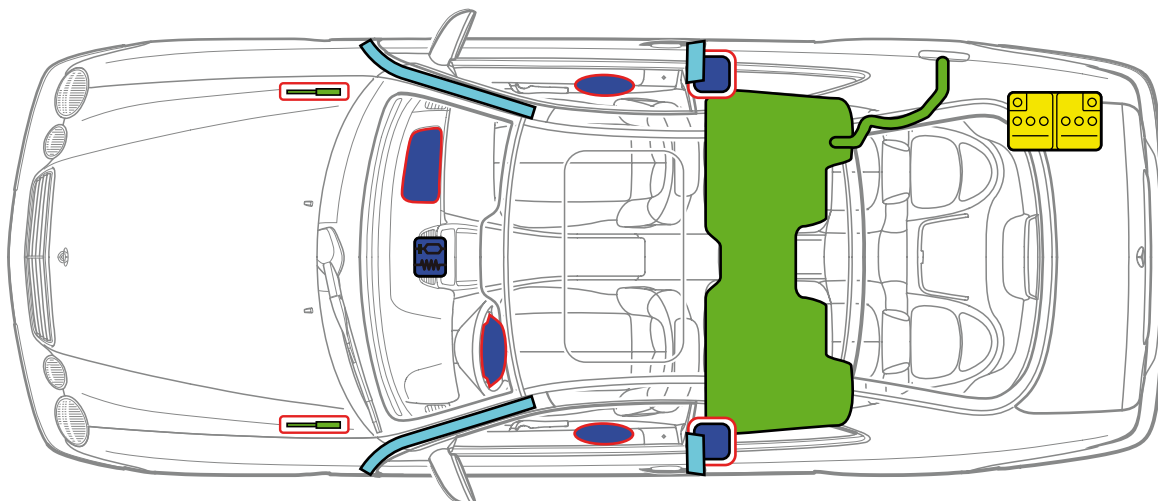
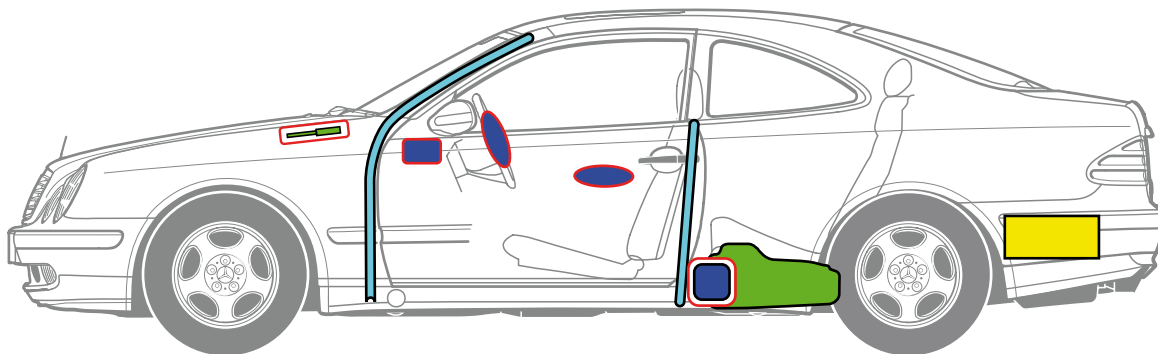

Airbag



Pretensionatore



Centralina di comando
sistemi di ritenuta



Ammortizzatore
pneumatico



Rinforzo carrozzeria



Serbatoio carburante



Batteria



Mercedes-Benz

Classe CLK coupé
tipo 209
2002 - 2009

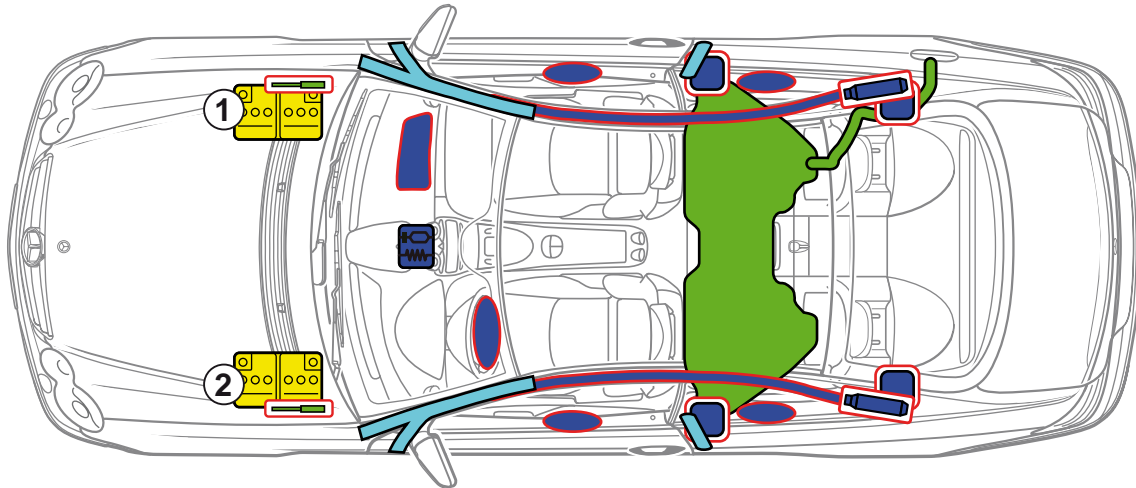
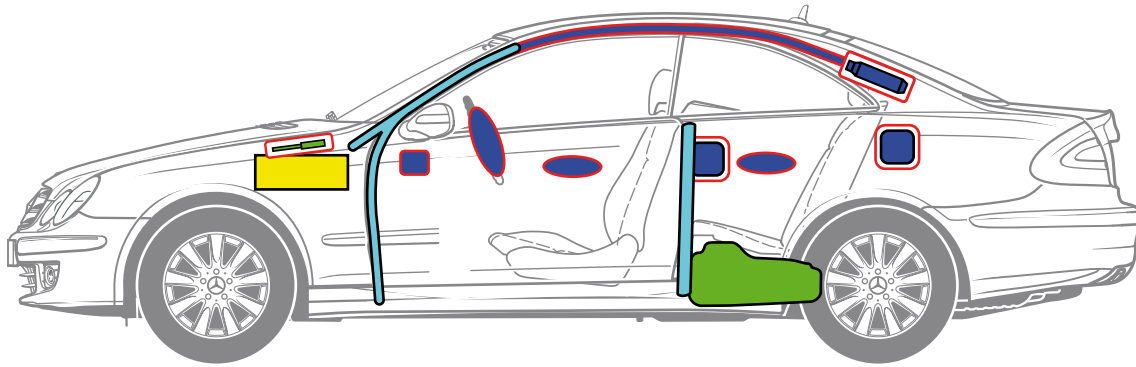
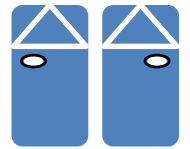

- 1 Veicolo con guida a sinistra
- 2 Veicolo con guida a destra

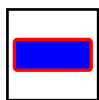

Airbag

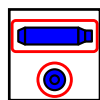

Generatore di gas

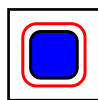

Pretensionatore

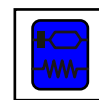

Centralina di comando sistemi di ritenuta



Ammortizzatore pneumatico

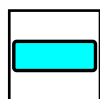

Rinforzo carrozzeria



Serbatoio carburante



Batteria



Mercedes-Benz

Classe CL coupé
tipo 215
1999 - 2006

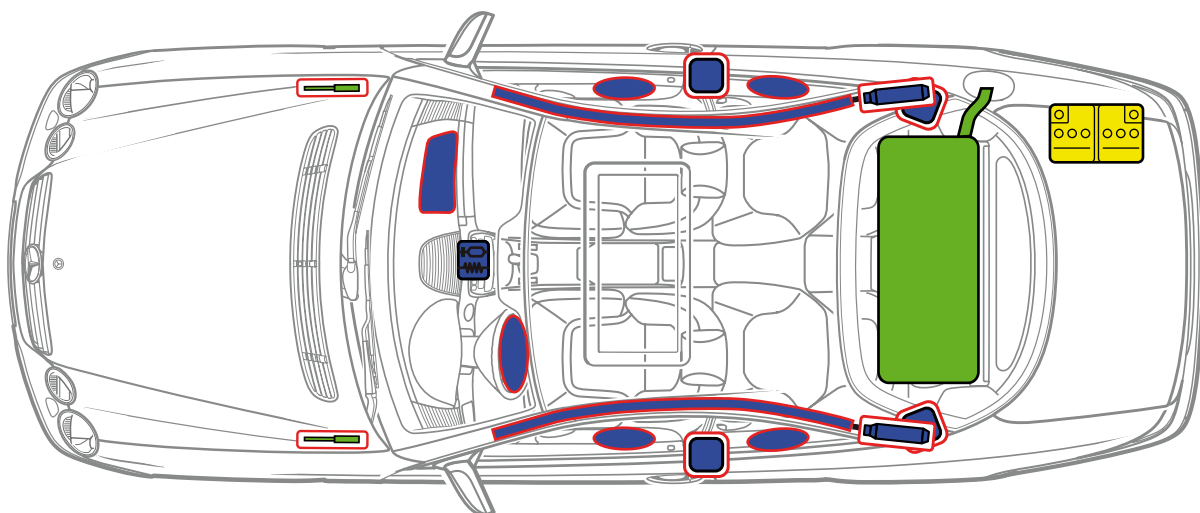
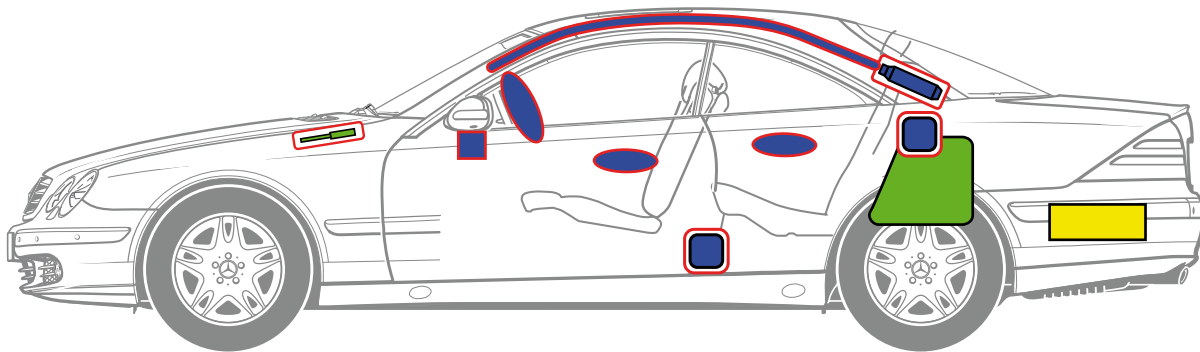

Airbag



Generatore di gas



Pretensionatore



Centralina di comando
sistemi di ritenuta



Ammortizzatore
pneumatico



Serbatoio carburante



Batteria



Mercedes-Benz

Classe CL coupé
tipo 216
a partire da 2006

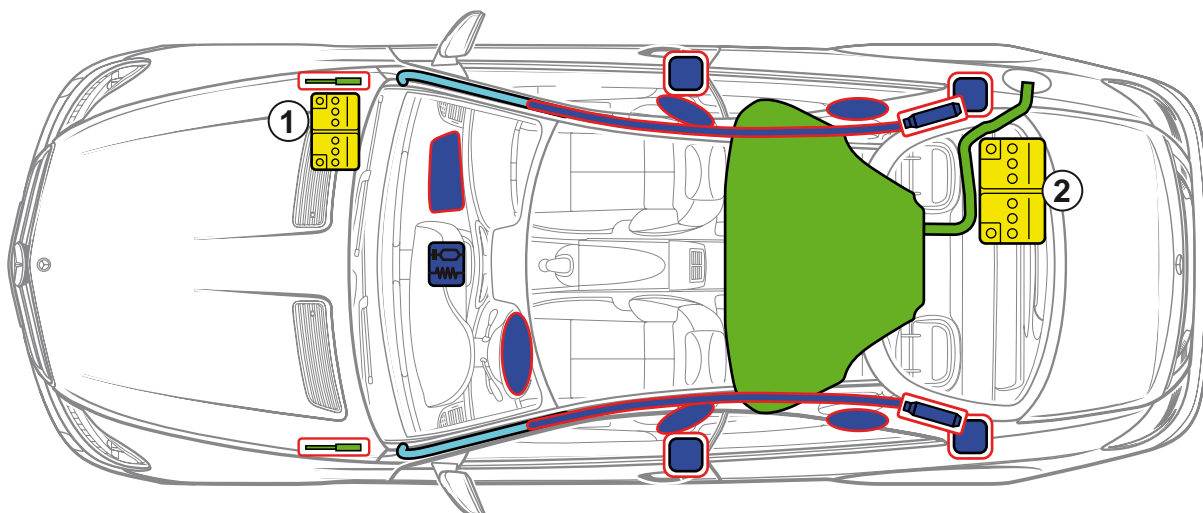
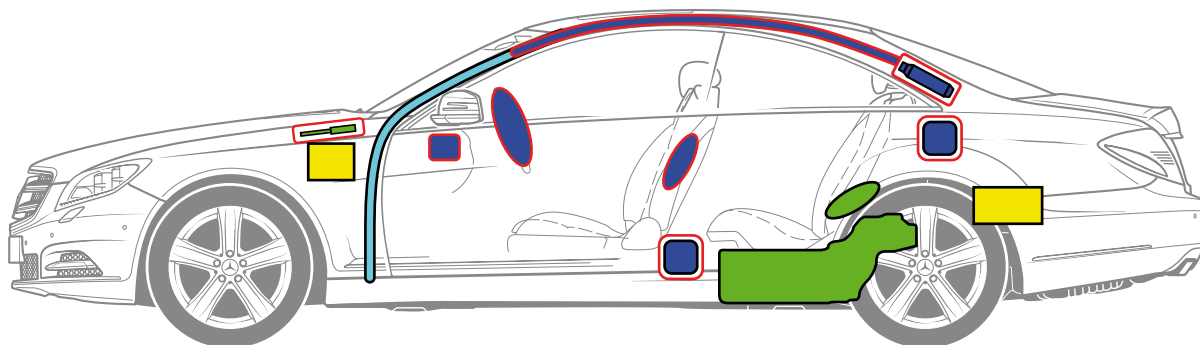

- 1 Batteria di avviamento vano motore
- 2 Batteria rete di bordo bagagliaio

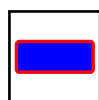

Airbag

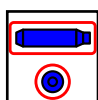

Generatore di gas

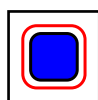

Pretensionatore

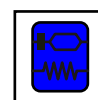

Centralina di comando
sistemi di ritenuta



Ammortizzatore
pneumatico



Rinforzo carrozzeria



Serbatoio carburante



Batteria



Mercedes-Benz

Classe CLS coupé
tipo 219
2004 - 2009

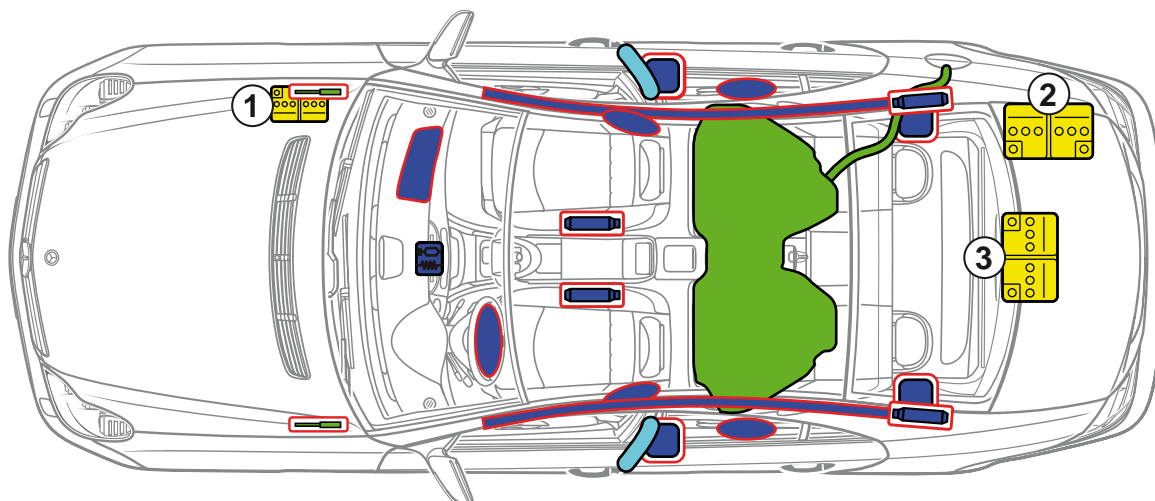
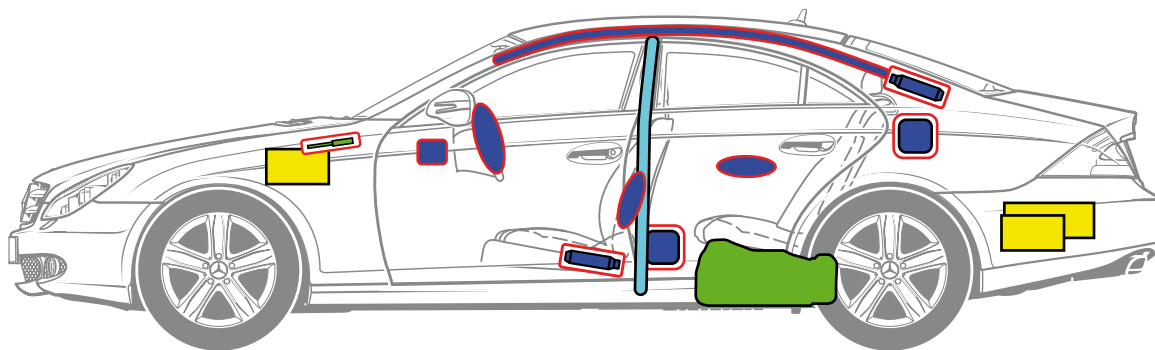

- 1 Batteria supplementare vano motore
- 2 Batteria principale bagagliaio (in caso di equipaggiamento con ruota di scorta)
- 3 Batteria principale bagagliaio (in caso di equipaggiamento senza ruota di scorta)



Airbag



Generatore di gas



Pretensionatore



Centralina di comando sistemi di ritenuta



Ammortizzatore pneumatico



Rinforzo carrozzeria



Serbatoio carburante



Batteria



Mercedes-Benz

Classe CLS coupé tipo 218 a partire da 2010

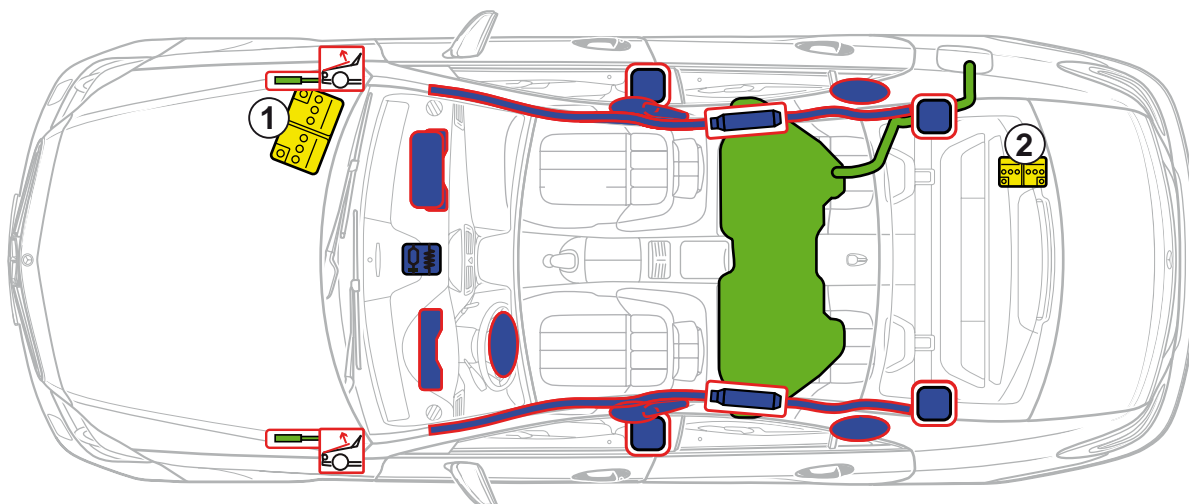
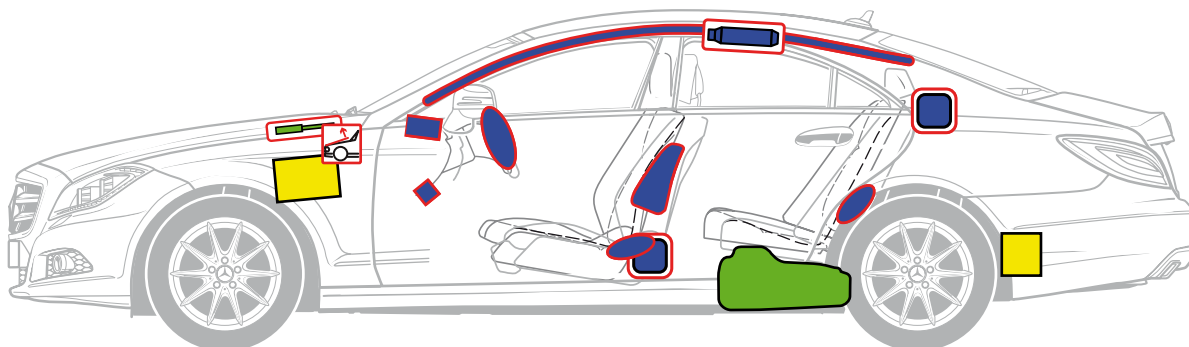

- 1 Batteria rete di bordo
- 2 Batteria supplementare ECO start/stop



Airbag



Generatore di gas



Pretensionatore



Centralina di comando sistemi di ritenuta



Ammortizzatore pneumatico



Protezione pedoni



Serbatoio carburante



Batteria



Mercedes-Benz

Classe CLS Shooting Brake tipo 218 a partire da 2012

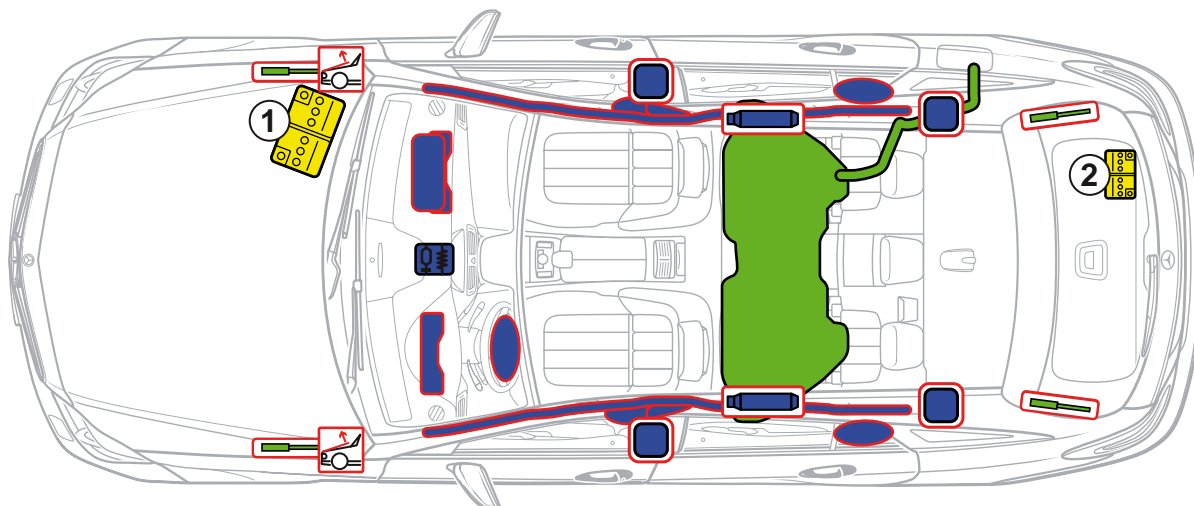
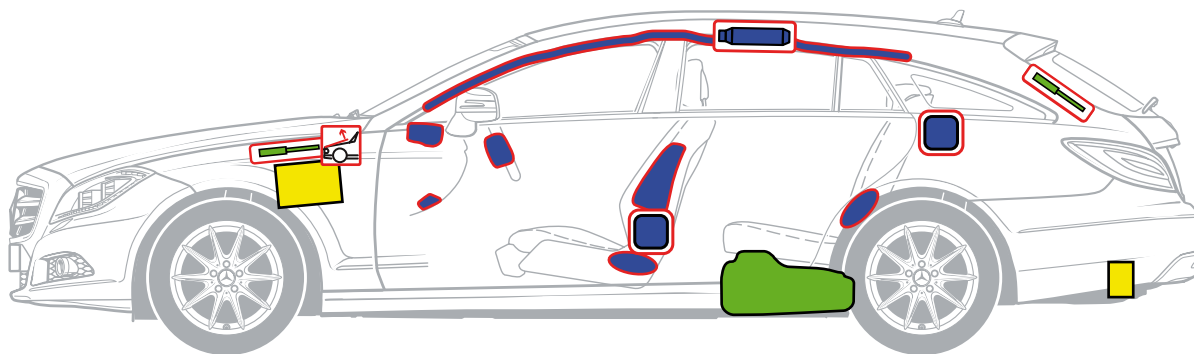

- 1 Batteria rete di bordo
- 2 Batteria supplementare ECO start/stop

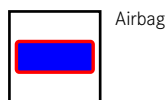

Airbag

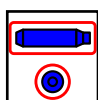

Generatore di gas

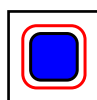

Pretensionatore

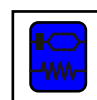

Centralina di comando sistemi di ritenuta

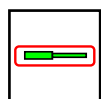

Ammortizzatore pneumatico



Protezione pedoni



Serbatoio carburante



Batteria



Mercedes-Benz

Classe E coupé
tipo 123
1977 - 1985

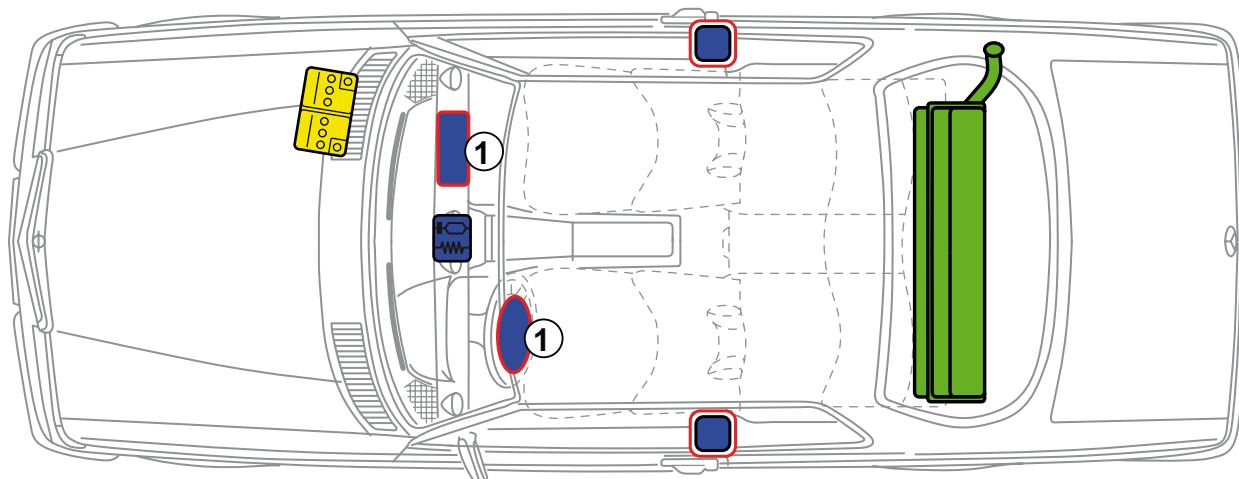
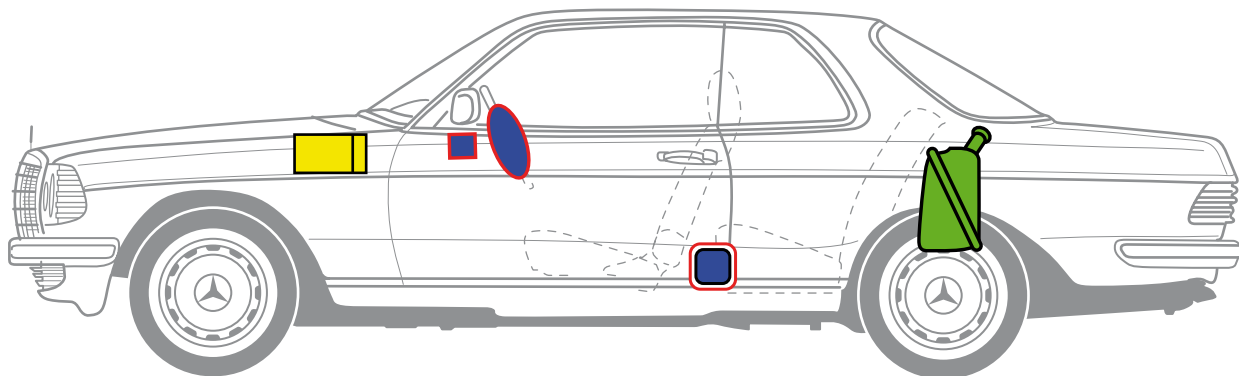

1 A partire da 1980



Airbag

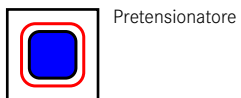

Pretensionatore

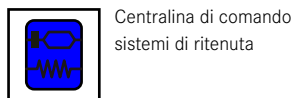

Centralina di comando
sistemi di ritenuta

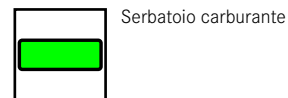

Serbatoio carburante

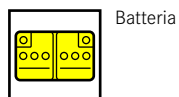

Batteria



Mercedes-Benz

Classe E coupé
tipo 124
1987 - 1997

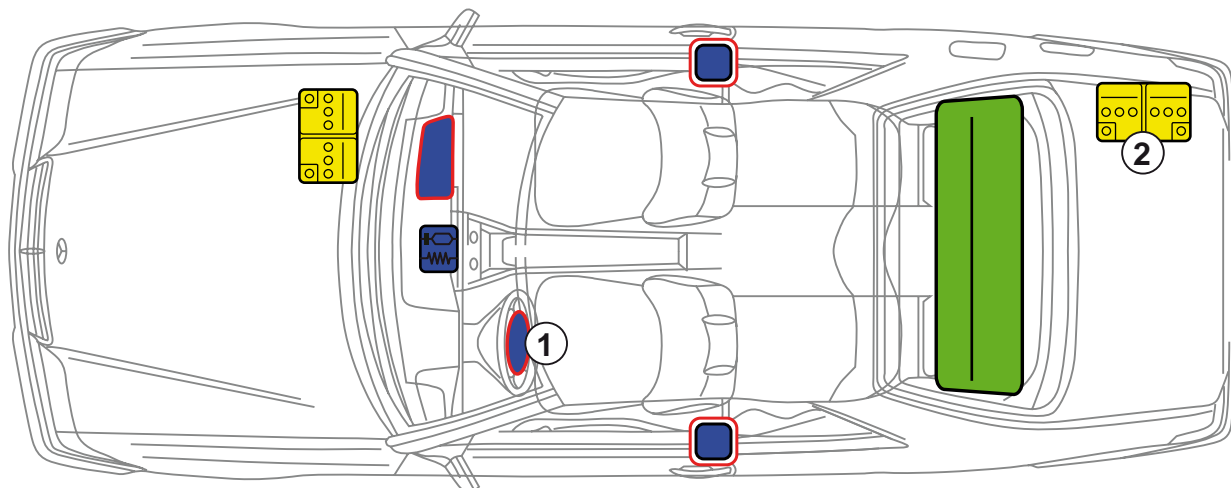
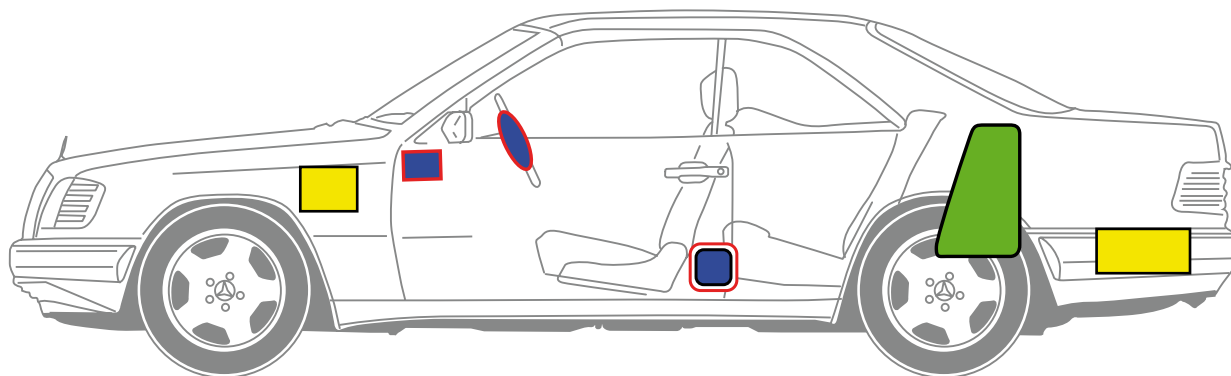

- 1 A partire da 1992 di serie
- 2 Batteria nel bagagliaio in caso di motore a 8 cilindri



Airbag

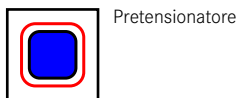

Pretensionatore

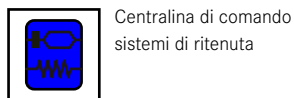

Centralina di comando
sistemi di ritenuta

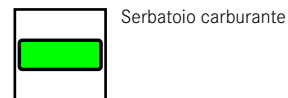

Serbatoio carburante

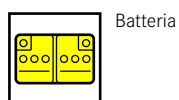

Batteria



Mercedes-Benz

Classe E coupé
tipo 207
2009 - 2012

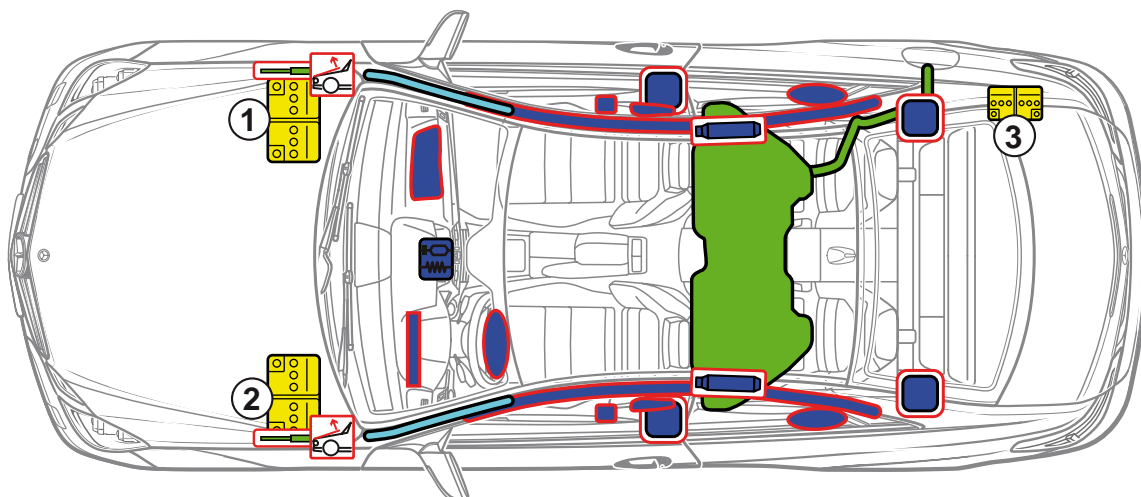
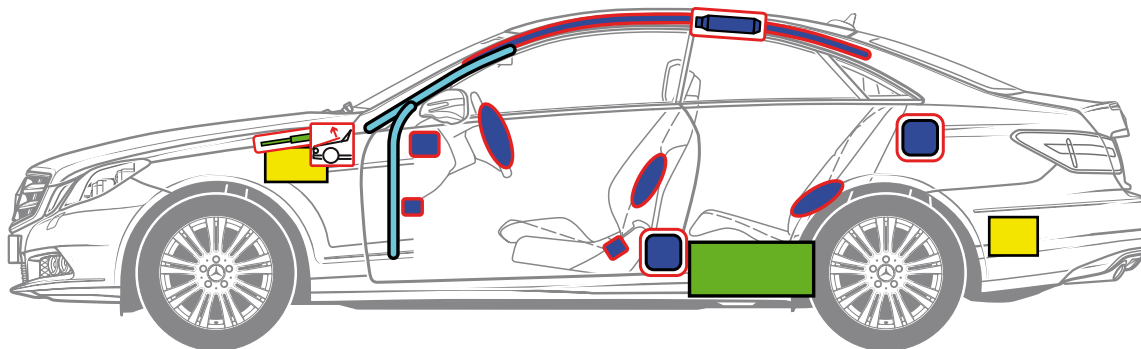
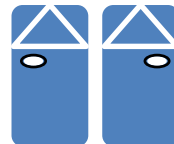

- 1 Batteria rete di bordo, veicolo con guida a sinistra
- 2 Batteria rete di bordo, veicolo con guida a destra
- 3 Batteria supplementare ECO start/stop



Airbag

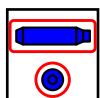

Generatore di gas



Pretensionatore



Centralina di comando sistemi di ritenuta



Ammortizzatore pneumatico



Protezione pedoni



Rinforzo carrozzeria



Serbatoio carburante



Batteria



Mercedes-Benz

Classe E coupé anno di produzione 2014
tipo 207
a partire da 2013

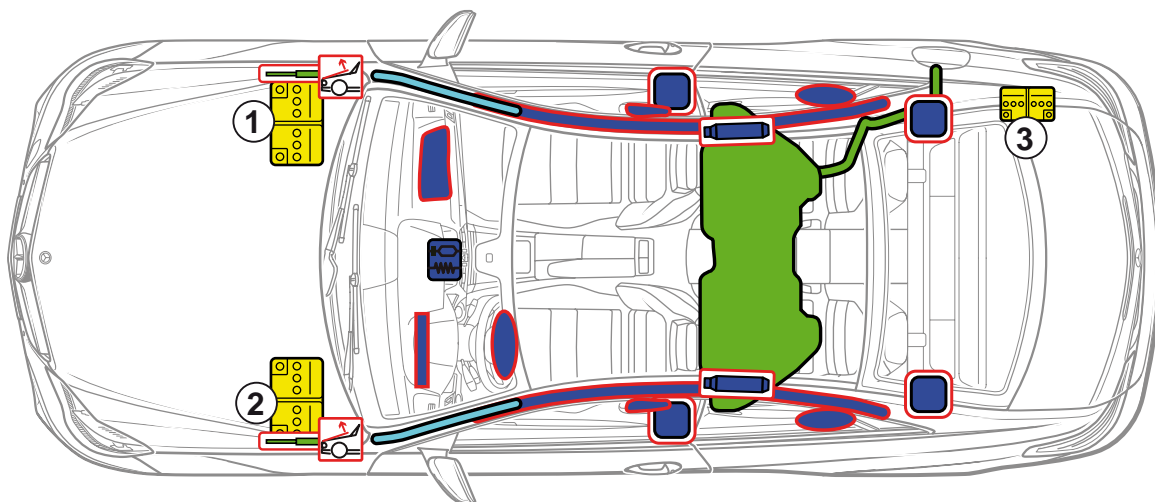
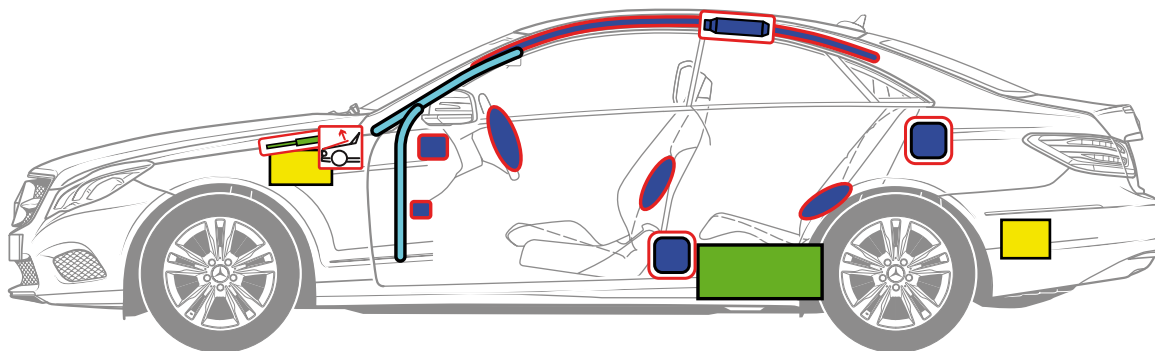
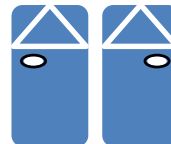

- 1 Batteria rete di bordo, veicolo con guida a sinistra
- 2 Batteria rete di bordo, veicolo con guida a destra
- 3 Batteria supplementare (equipaggiamento speciale)

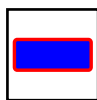

Airbag

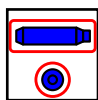

Generatore di gas

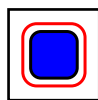

Pretensionatore

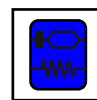

Centralina di comando sistemi di ritenuta



Ammortizzatore pneumatico



Protezione pedoni



Rinforzo carrozzeria



Serbatoio carburante



Batteria



Mercedes-Benz

Classe SLC coupé
tipo 107
1971 - 1989

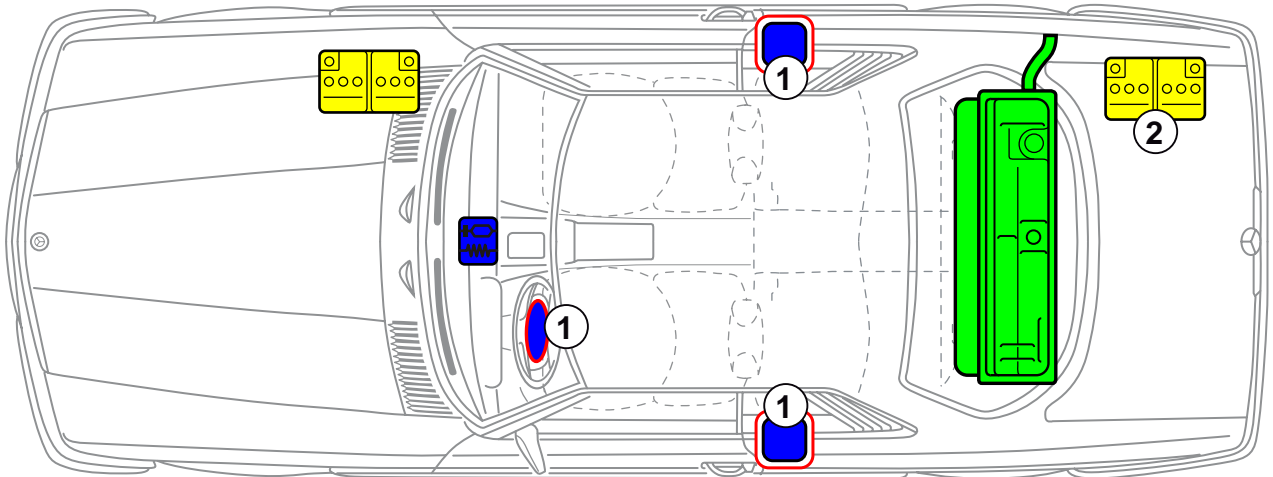
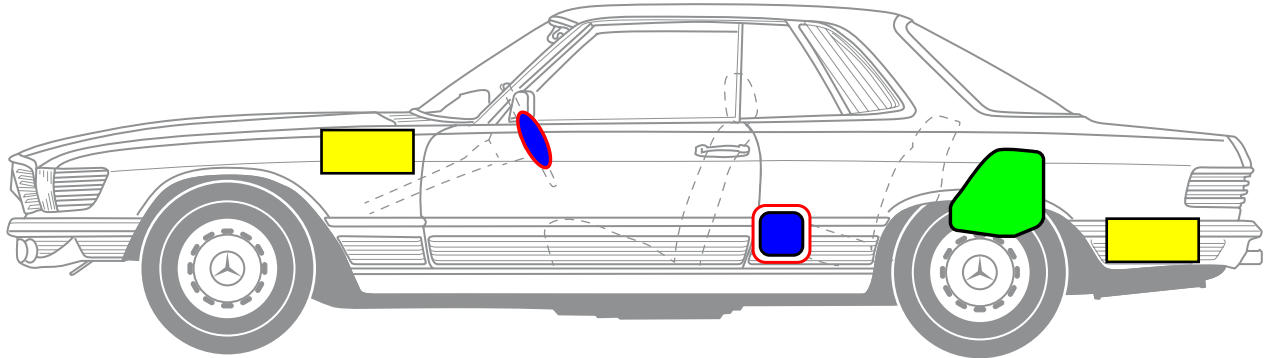

- 1 A partire da 1982
- 2 USA/Giappone con motore a 8 cilindri



Airbag

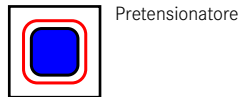

Pretensionatore

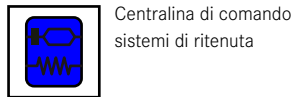

Centralina di comando
sistemi di ritenuta



Serbatoio carburante

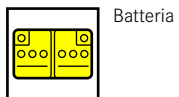

Batteria



Mercedes-Benz

Classe S coupé
tipo 126
1981 - 1991

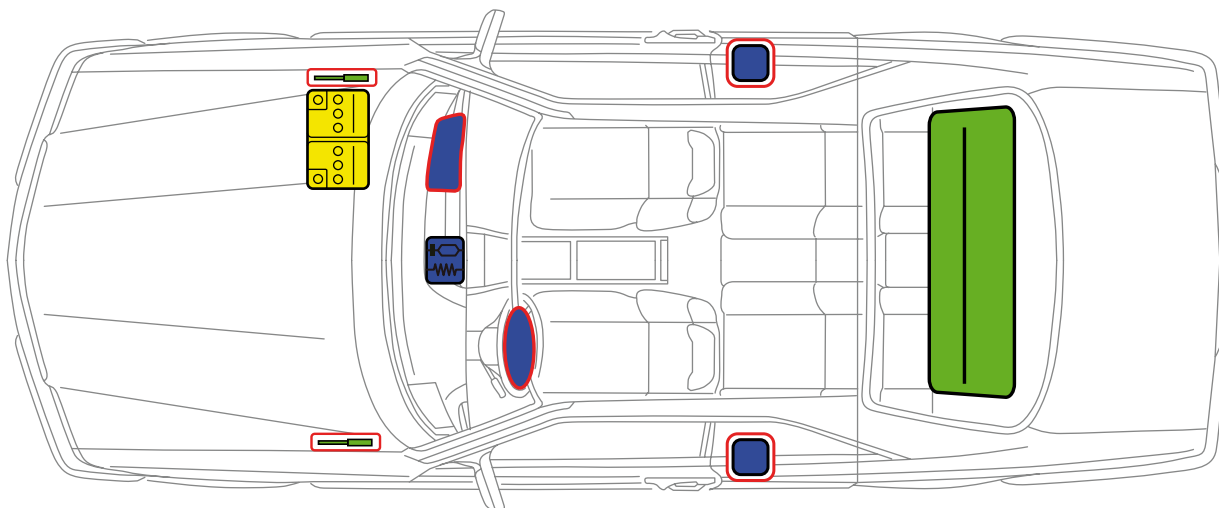
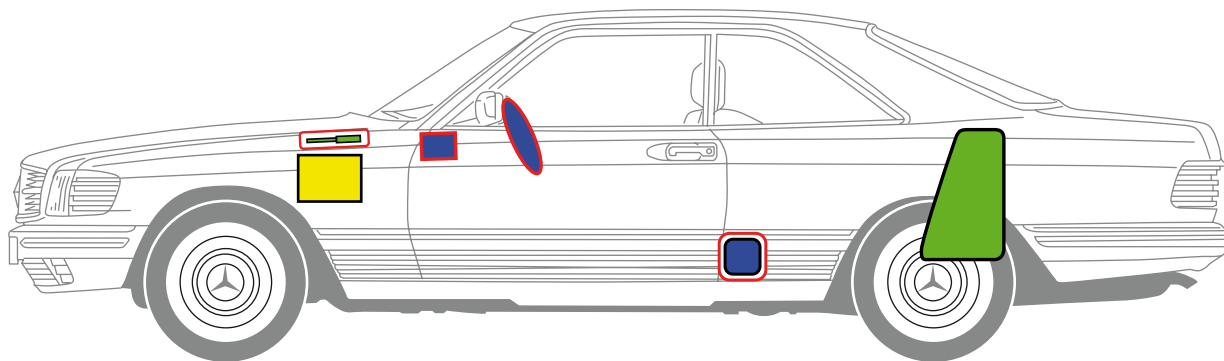

Airbag

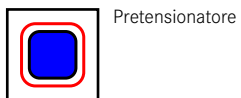

Pretensionatore

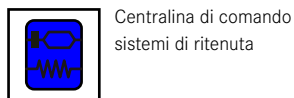

Centralina di comando
sistemi di ritenuta

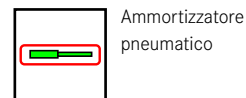

Ammortizzatore
pneumatico



Serbatoio carburante

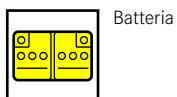

Batteria



Mercedes-Benz

Classe S coupé
tipo 140
1992 - 1998

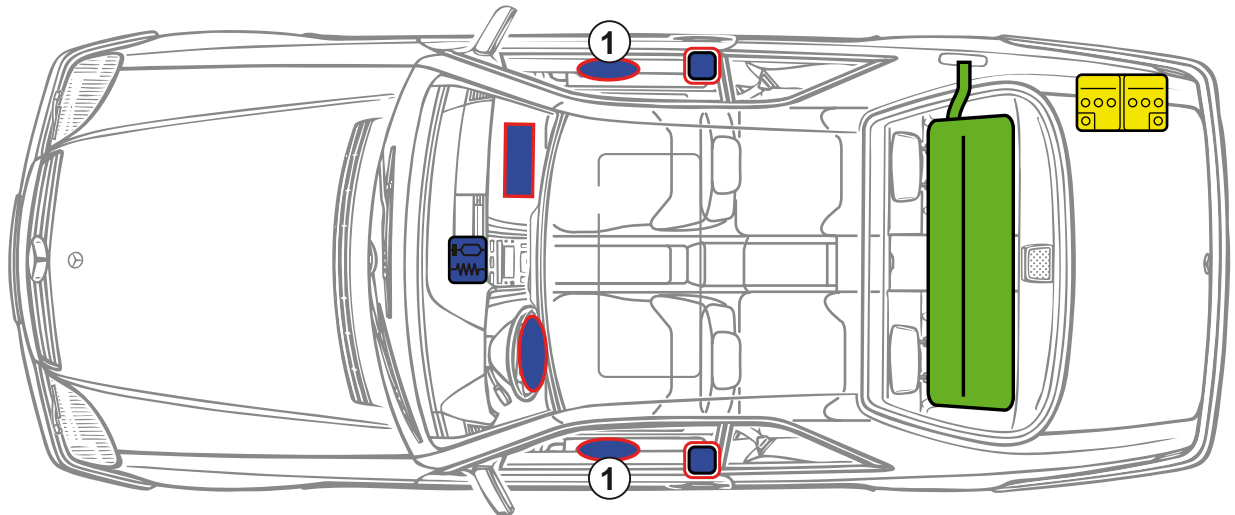
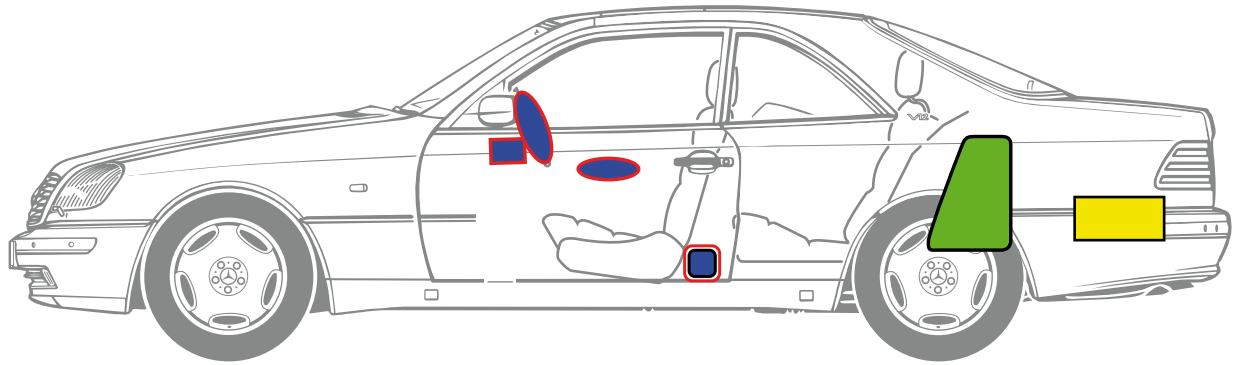

1 Equipaggiamento speciale



Airbag



Pretensionatore



Centralina di comando
sistemi di ritenuta



Serbatoio carburante



Batteria



Mercedes-Benz

Classe CLK cabriolet
tipo 208
1997 - 2002

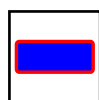
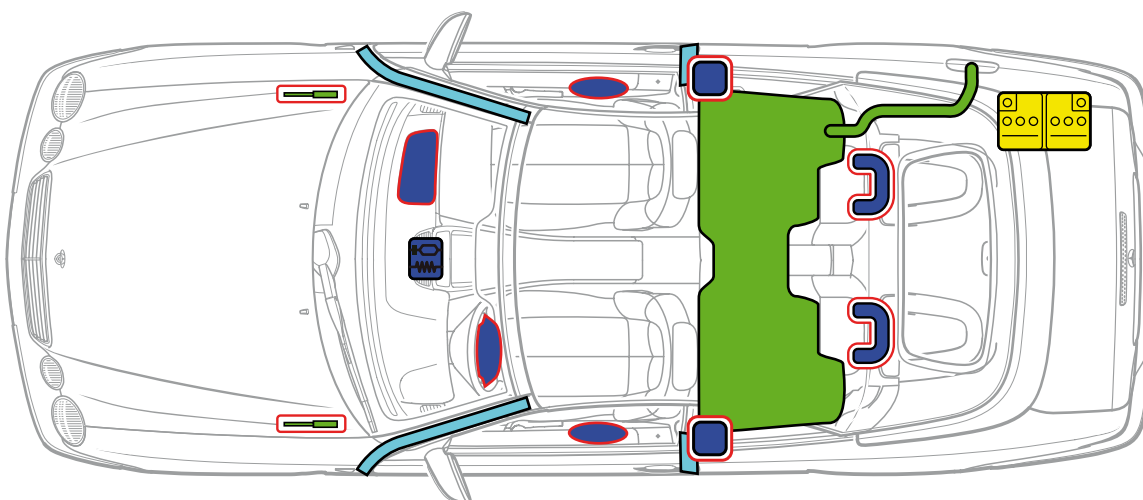
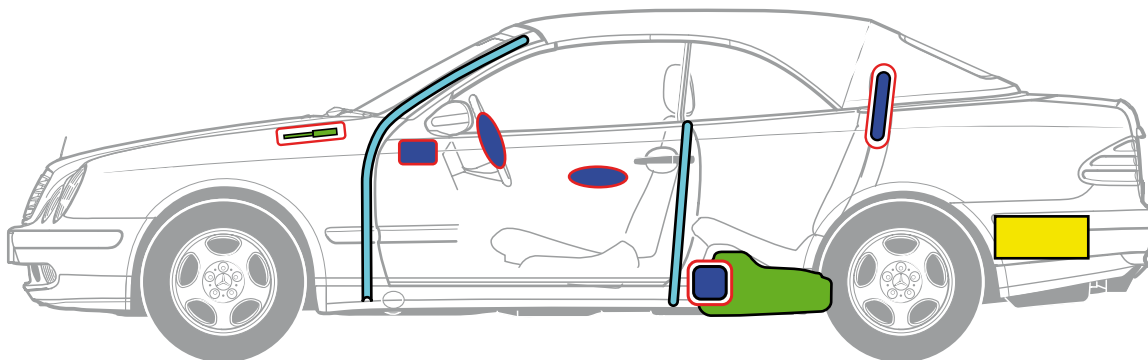

Airbag

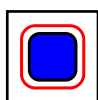

Pretensionatore

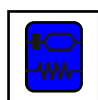

Centralina di comando
sistemi di ritenuta



Protezione
anticapottamento



Ammortizzatore
pneumatico



Rinforzo carrozzeria



Serbatoio carburante



Batteria



Mercedes-Benz

Classe CLK cabriolet
tipo 209
2003 - 2009

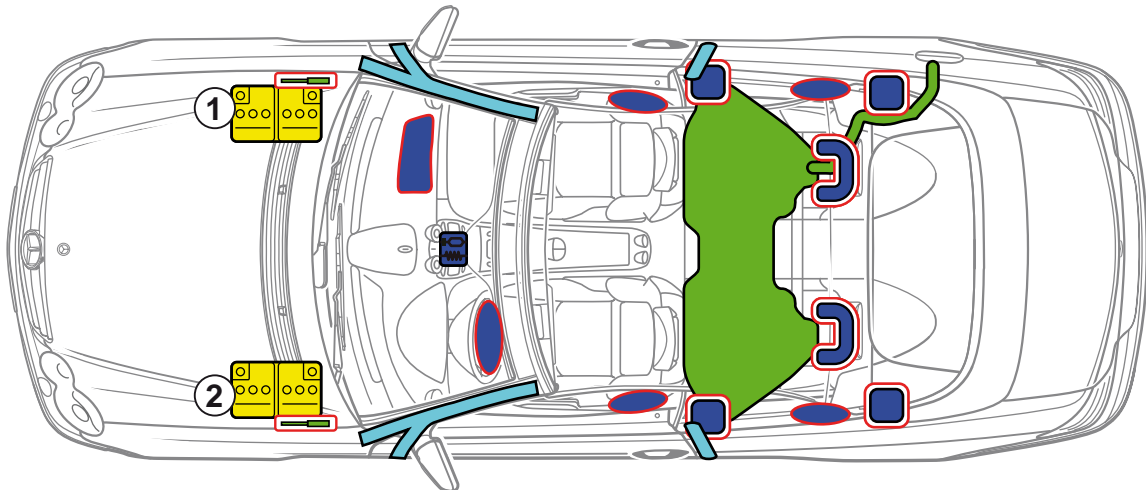
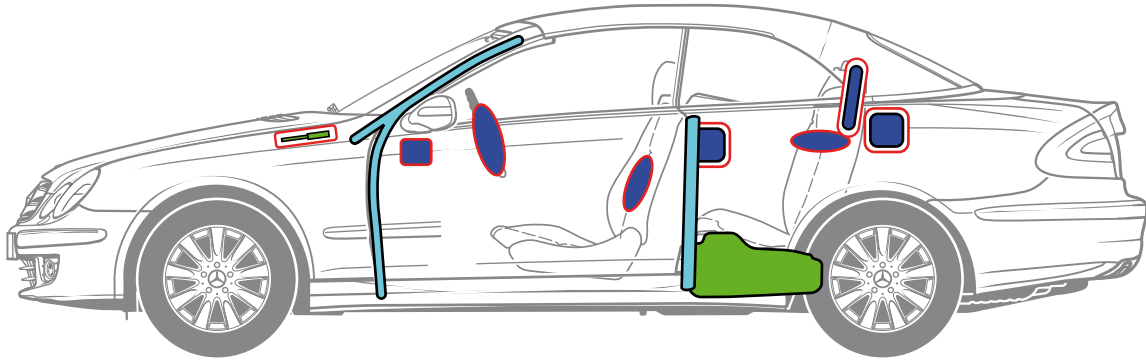
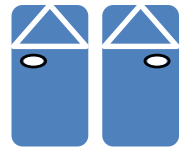

- 1 Veicolo con guida a sinistra
- 2 Veicolo con guida a destra

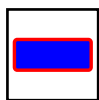

Airbag

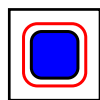

Pretensionatore

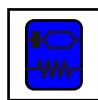

Centralina di comando sistemi di ritenuta

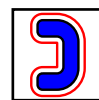

Protezione anticapottamento



Ammortizzatore pneumatico

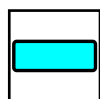

Rinforzo carrozzeria



Serbatoio carburante



Batteria



Mercedes-Benz

Classe E cabriolet
tipo 124
1987 - 1997

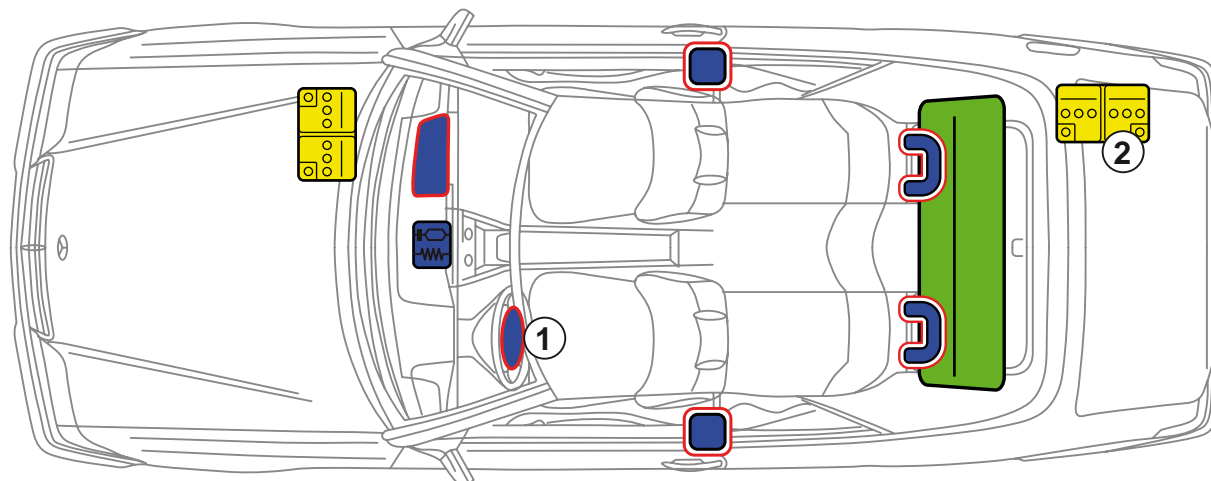
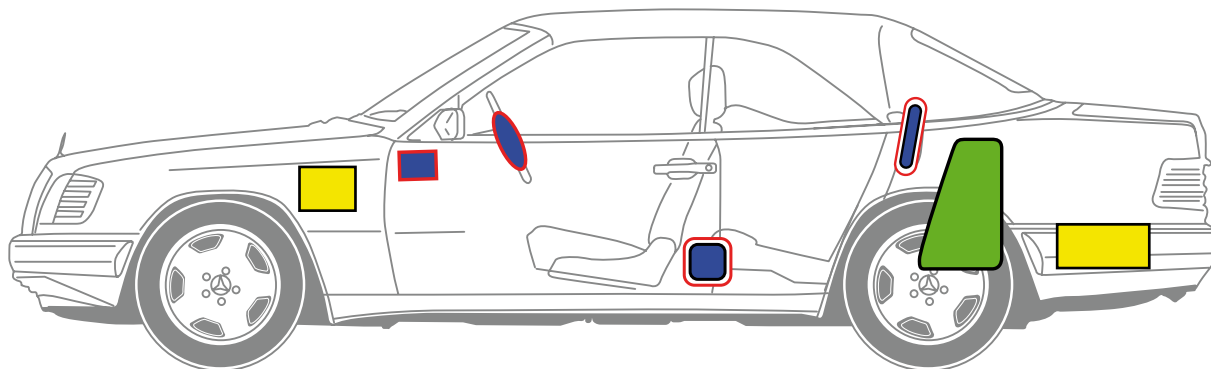

- 1 A partire da 1992 di serie
- 2 Batteria nel bagagliaio in caso di motore a 8 cilindri



Airbag

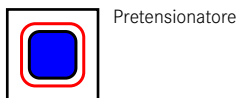

Pretensionatore

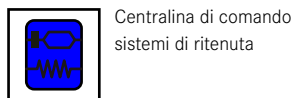

Centralina di comando sistemi di ritenuta

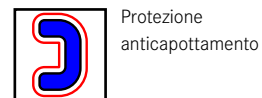

Protezione anticapottamento



Serbatoio carburante

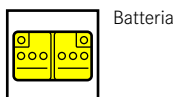

Batteria



Mercedes-Benz

Classe E cabriolet
tipo 207
2010 - 2012

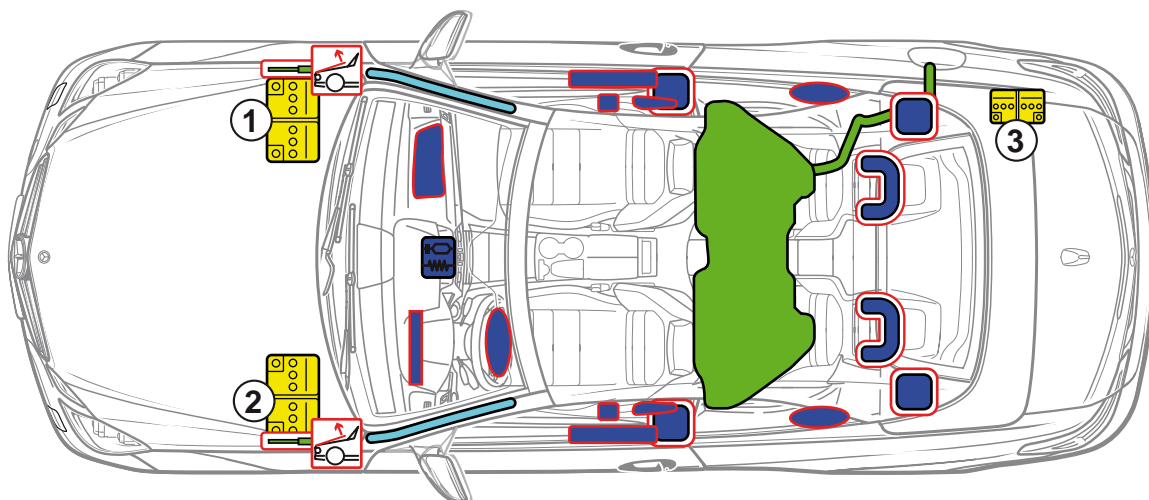
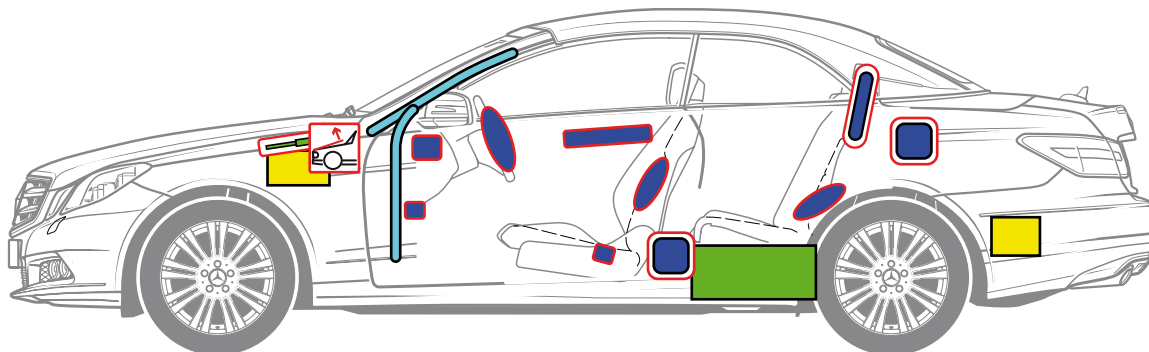
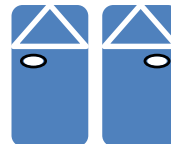

- 1 Batteria rete di bordo, veicolo con guida a sinistra
- 2 Batteria rete di bordo, veicolo con guida a destra
- 3 Batteria supplementare ECO start/stop



Airbag



Pretensionatore



Centralina di comando sistemi di ritenuta



Protezione anticapottamento



Ammortizzatore pneumatico



Rinforzo carrozzeria



Protezione pedoni



Serbatoio carburante



Batteria



Mercedes-Benz

Classe E cabriolet anno di produzione 2014
tipo 207
a partire da 2013

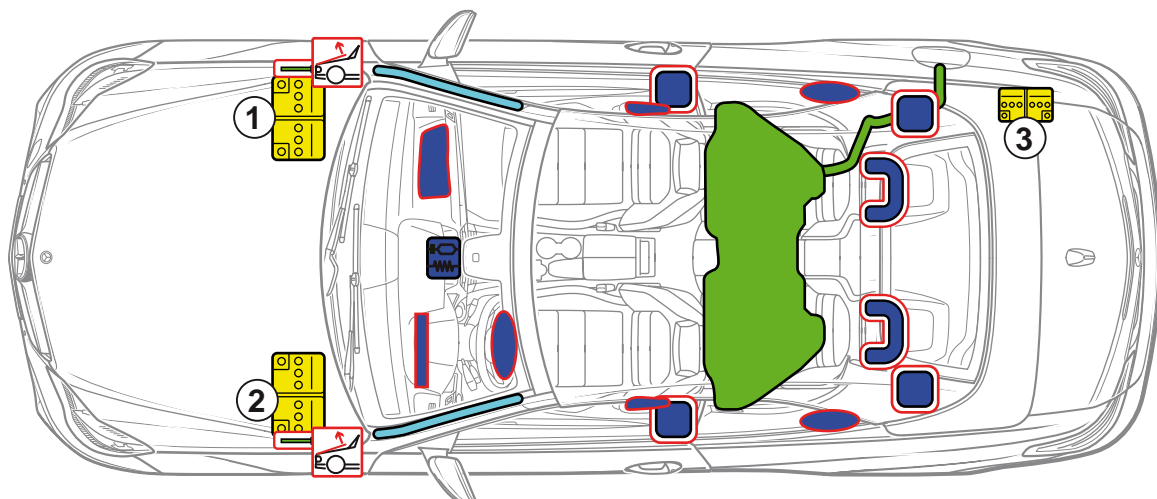
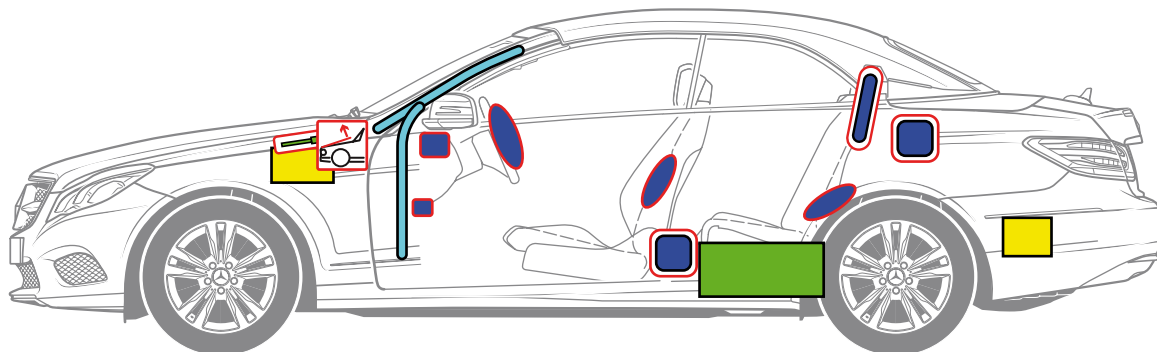
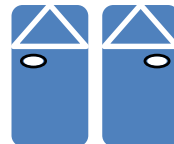

- 1 Batteria rete di bordo, veicolo con guida a sinistra
- 2 Batteria rete di bordo, veicolo con guida a destra
- 3 Batteria supplementare (equipaggiamento speciale)



Airbag



Pretensionatore



Centralina di comando sistemi di ritenuta



Protezione anticapottamento



Ammortizzatore pneumatico



Rinforzo carrozzeria



Protezione pedoni



Serbatoio carburante



Batteria



Mercedes-Benz

Classe SLK roadster
tipo 170
1996 - 2004

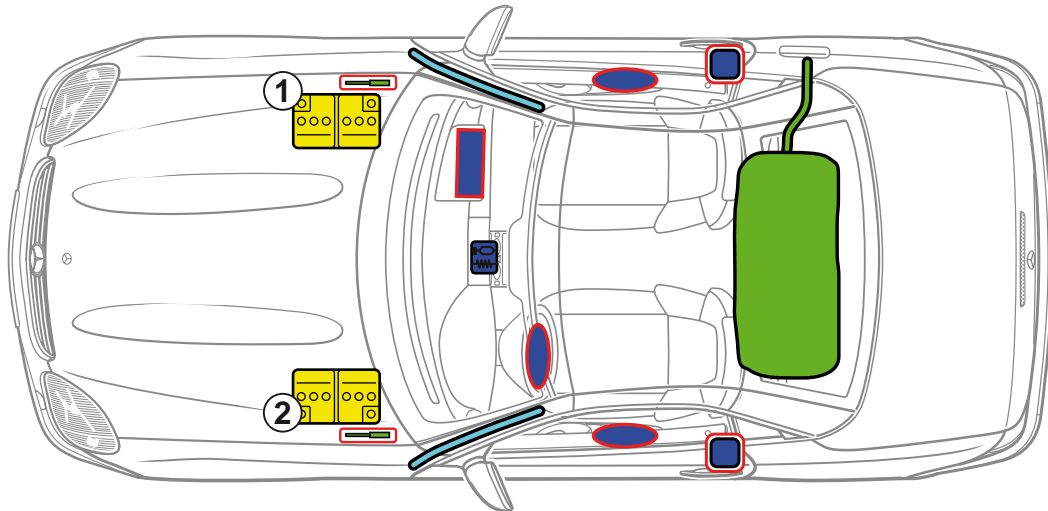
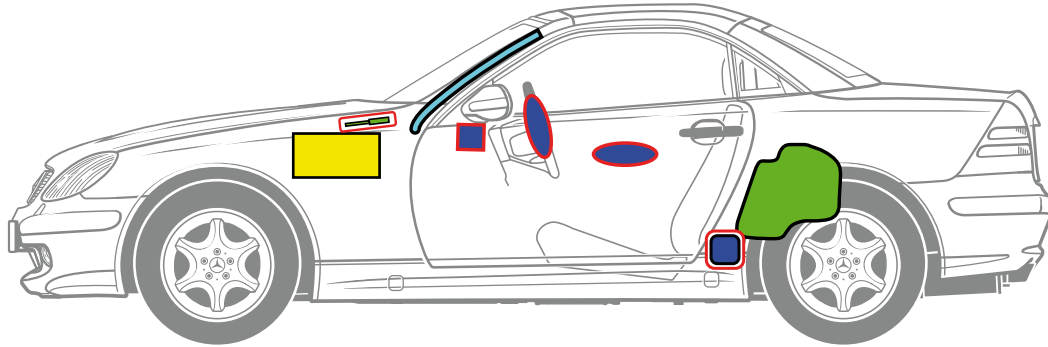
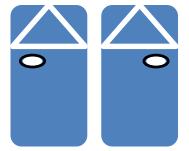

- 1 Veicolo con guida a sinistra
- 2 Veicolo con guida a destra

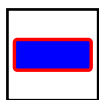

Airbag

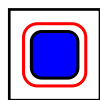

Pretensionatore

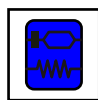

Centralina di comando sistemi di ritenuta



Ammortizzatore pneumatico



Rinforzo carrozzeria

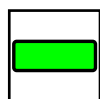

Serbatoio carburante



Batteria



Mercedes-Benz

Classe SLK roadster
tipo 171
2004 - 2011

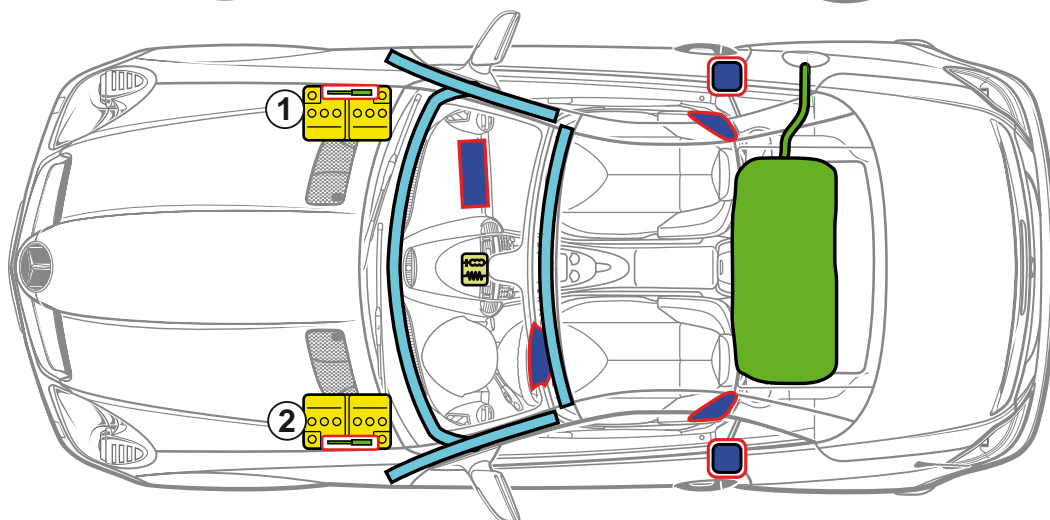
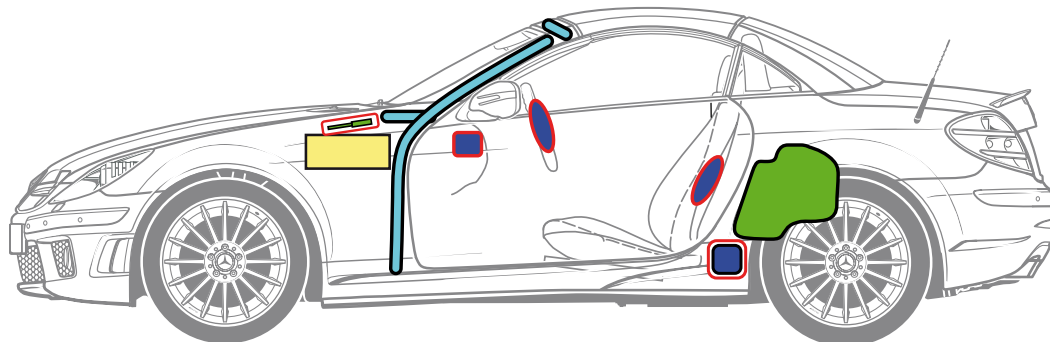
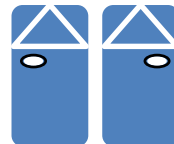

- 1 Veicolo con guida a sinistra
- 2 Veicolo con guida a destra



Airbag

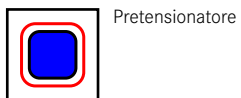

Pretensionatore

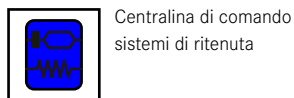

Centralina di comando sistemi di ritenuta

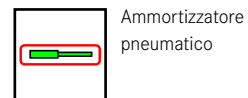

Ammortizzatore pneumatico



Rinforzo carrozzeria



Serbatoio carburante

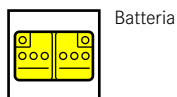

Batteria



Mercedes-Benz

Classe SLK roadster
tipo 172
a partire da 2011

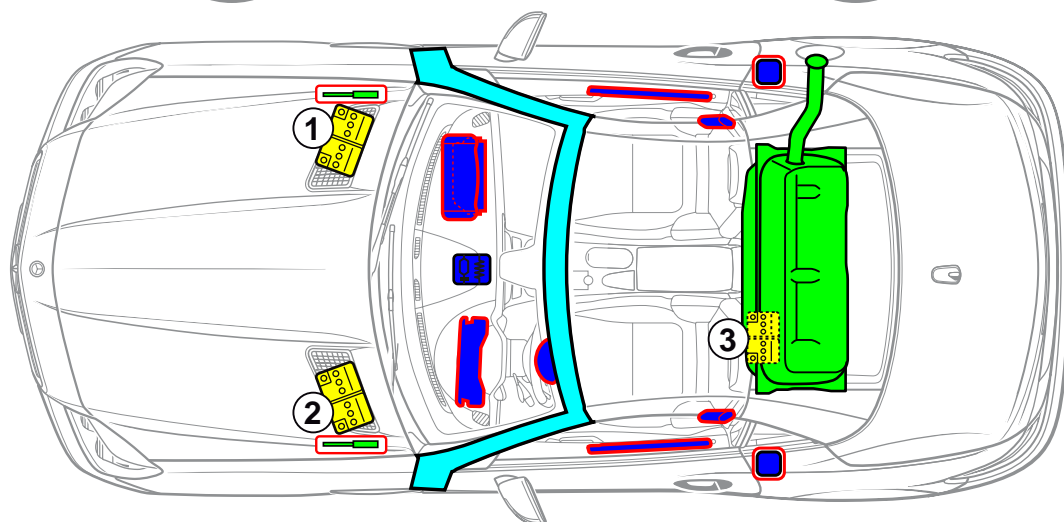
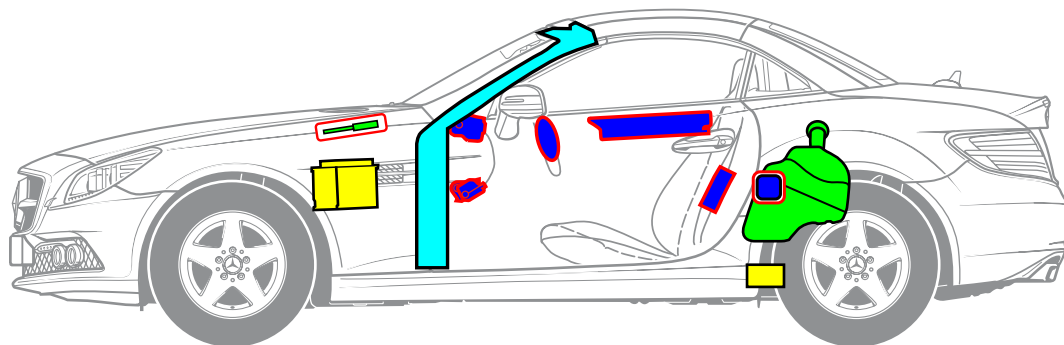
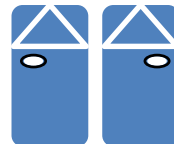

- 1 Batteria rete di bordo, veicolo con guida a sinistra
- 2 Batteria rete di bordo, veicolo con guida a destra
- 3 Batteria supplementare ECO start/stop



Airbag

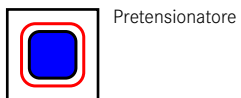

Pretensionatore

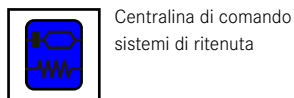

Centralina di comando sistemi di ritenuta

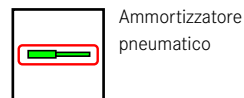

Ammortizzatore pneumatico

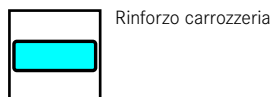

Rinforzo carrozzeria

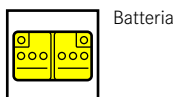

Batteria



Mercedes-Benz

Classe SL roadster
tipo 107
1971 - 1989

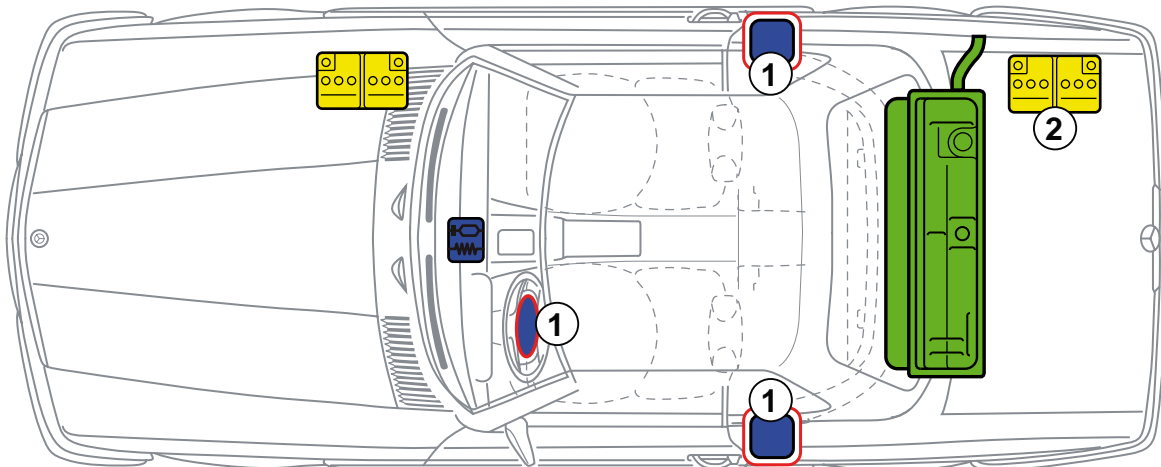
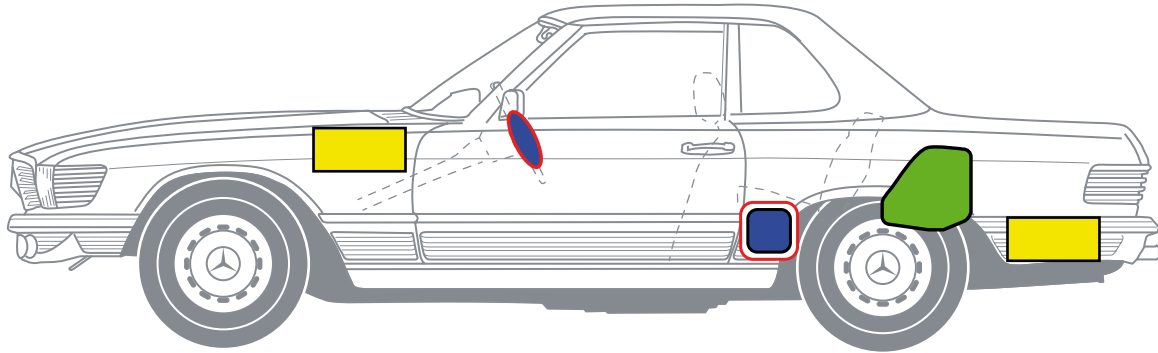

- 1 A partire da 1982
- 2 USA/Giappone con motore a 8 cilindri



Airbag

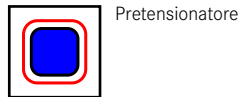

Pretensionatore

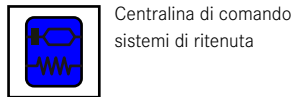

Centralina di comando
sistemi di ritenuta



Serbatoio carburante

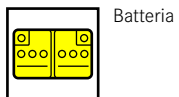

Batteria



Mercedes-Benz

Classe SL roadster
tipo 129
1989 - 2001

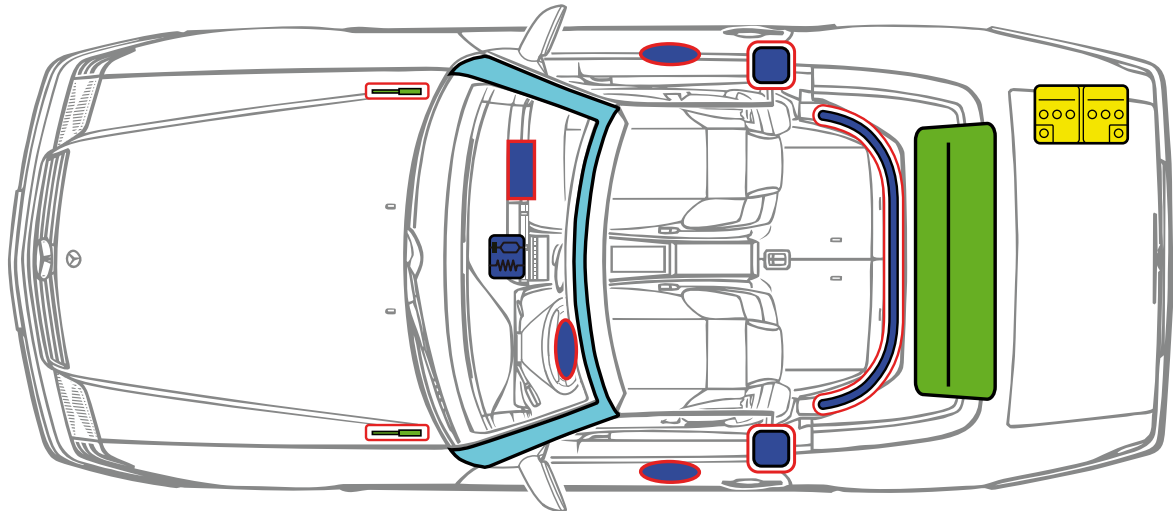
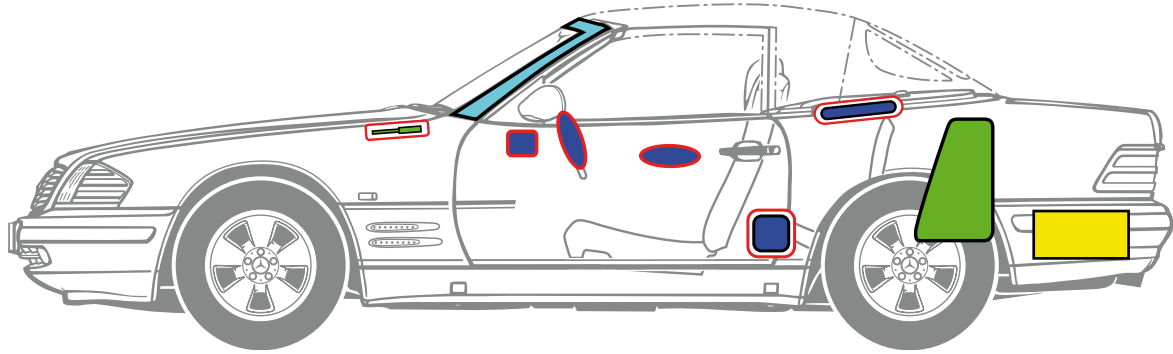

Airbag

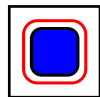

Pretensionatore



Centralina di comando
sistemi di ritenuta



Protezione
anticapottamento



Ammortizzatore
pneumatico

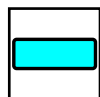

Rinforzo carrozzeria



Serbatoio carburante



Batteria



Mercedes-Benz

Classe SL roadster
tipo 230
2001 - 2011

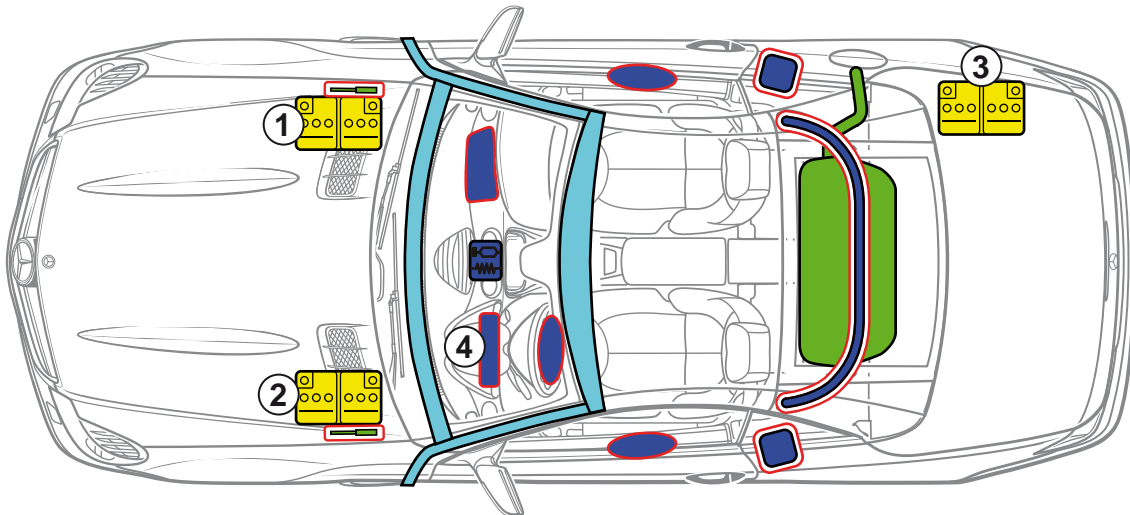
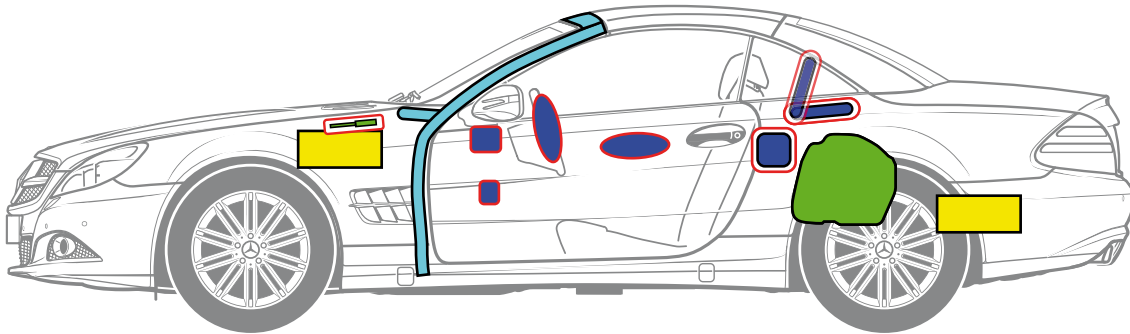
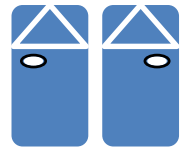

- 1 Batteria di avviamento veicolo con guida a sinistra
- 2 Batteria di avviamento veicolo con guida a destra
- 3 Batteria rete di bordo
- 4 Airbag per le ginocchia conducente (USA)



Airbag



Pretensionatore



Centralina di comando sistemi di ritenuta



Protezione anticapottamento



Ammortizzatore pneumatico



Rinforzo carrozzeria



Serbatoio carburante



Batteria



Mercedes-Benz

Classe SL roadster
tipo 231
a partire da 2012

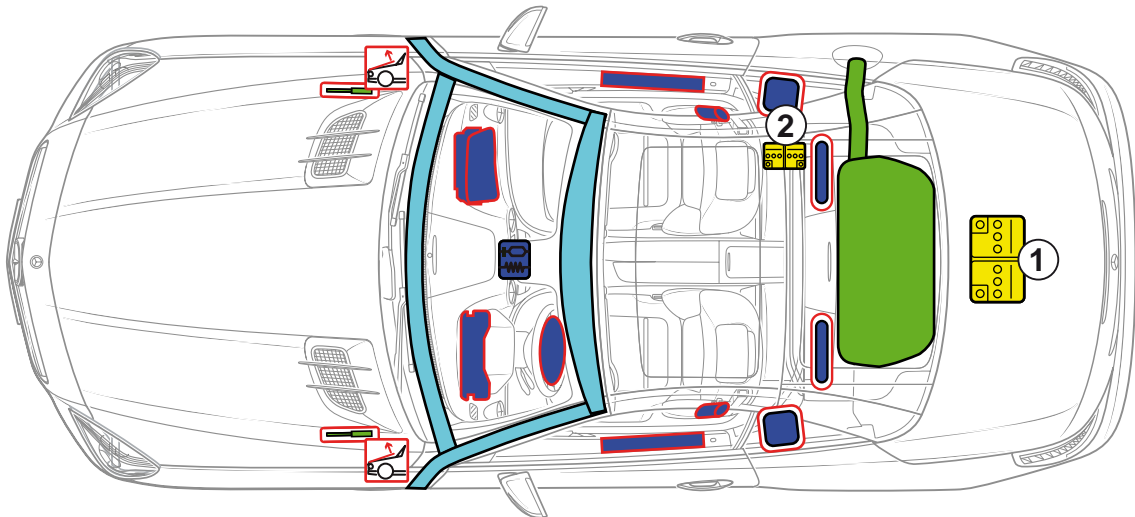
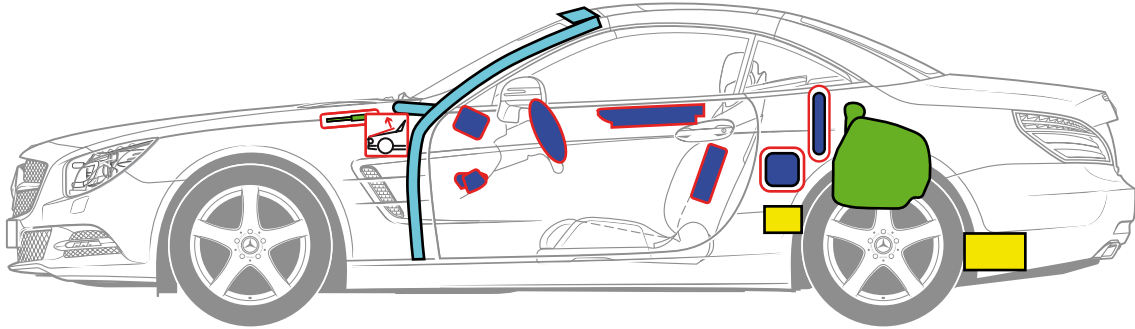

- 1 Batteria rete di bordo
- 2 Batteria supplementare ECO start/stop

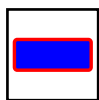

Airbag

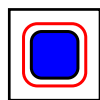

Pretensionatore

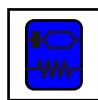

Centralina di comando
sistemi di ritenuta

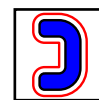

Protezione
anticapottamento



Ammortizzatore
pneumatico

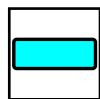

Rinforzo carrozzeria



Protezione pedoni



Serbatoio carburante

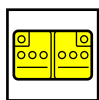

Batteria



Mercedes-Benz

SLR McLaren
tipo 199
2004 - 2009

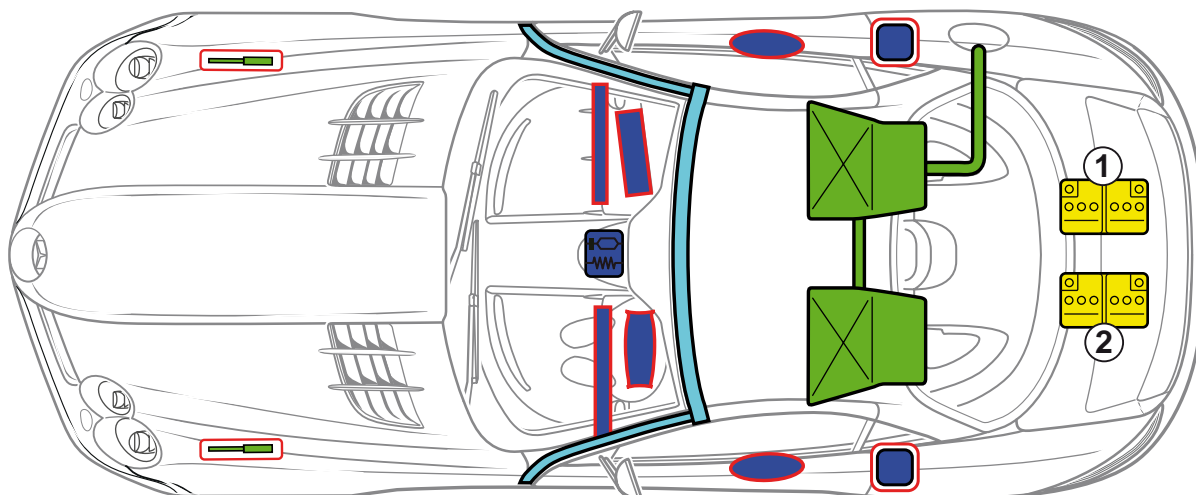
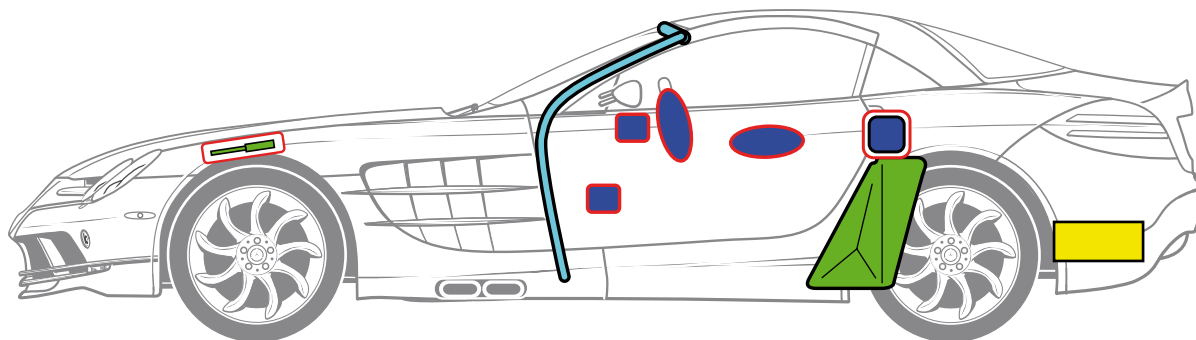

- 1 Batteria di avviamento
- 2 Batteria rete di bordo



Airbag

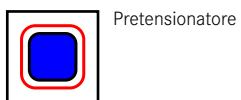

Pretensionatore

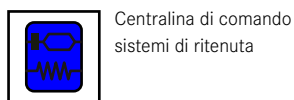

Centralina di comando sistemi di ritenuta

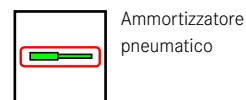

Ammortizzatore pneumatico



Rinforzo carrozzeria



Serbatoio carburante

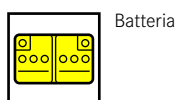

Batteria



Mercedes-Benz

Classe G fuoristrada
tipo 461/463
a partire da 1990

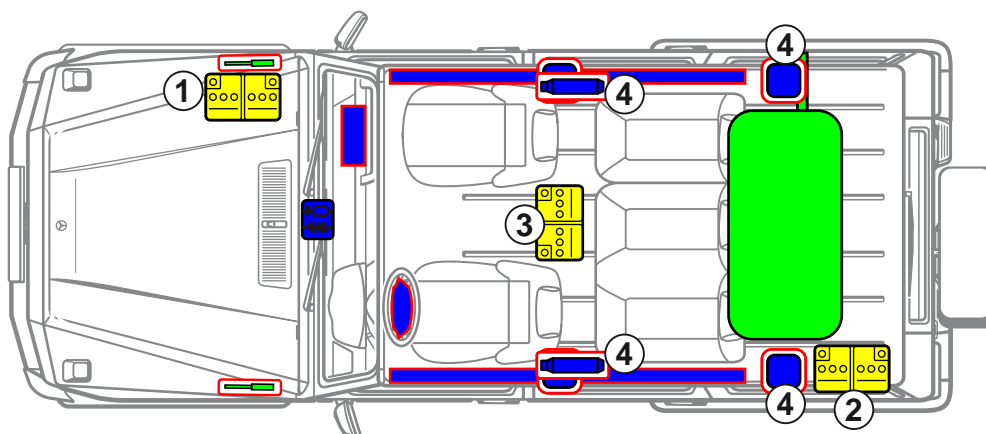
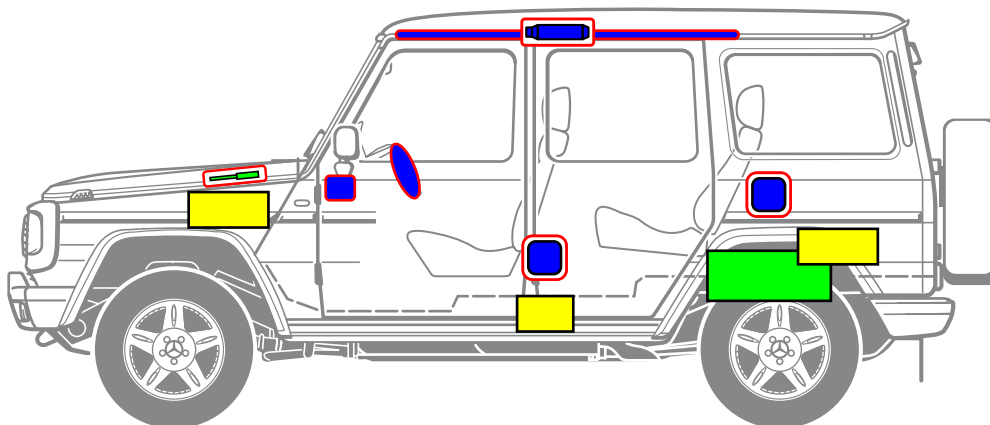

- 1 Fino a 09.1996
- 2 A partire da 10.1996 fino a 11.2000
- 3 A partire da 12.2000
- 4 Solo tipo 463



Airbag



Generatore di gas



Pretensionatore



Centralina di comando
sistemi di ritenuta



Ammortizzatore
pneumatico



Serbatoio carburante



Batteria



Mercedes-Benz

Classe GLA fuoristrada tipo 156 a partire da 2014

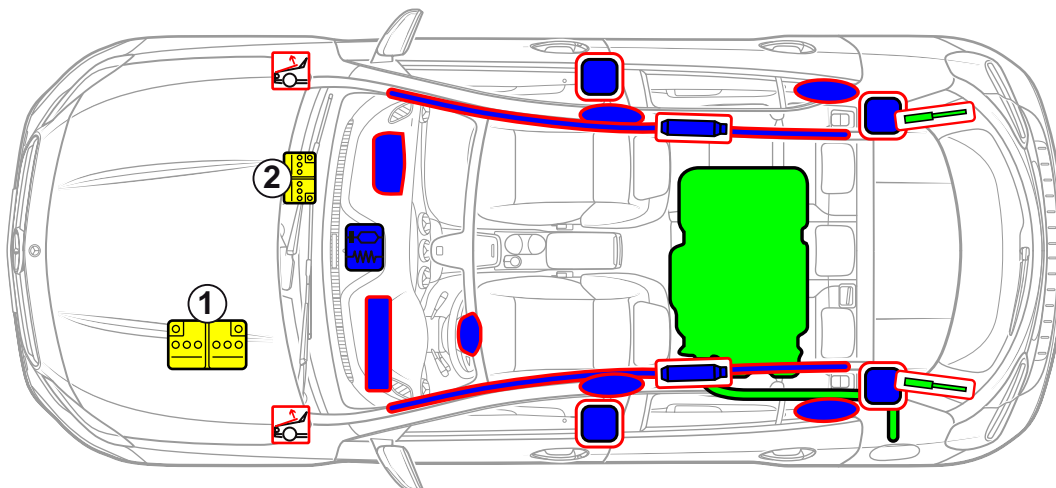
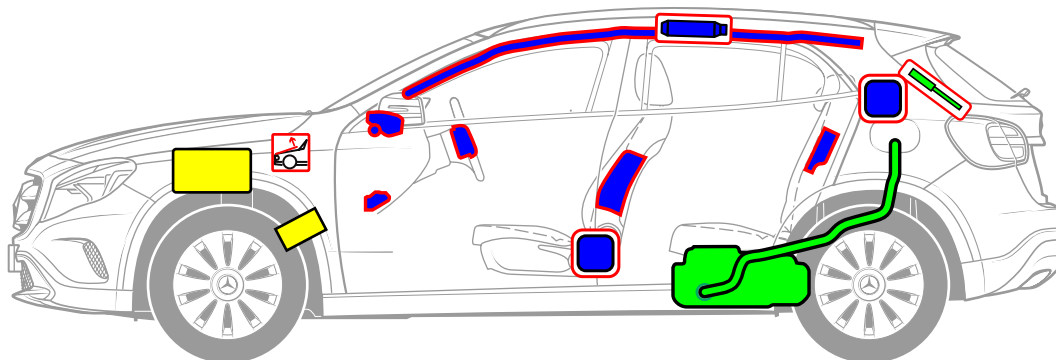

- 1 Batteria rete di bordo
- 2 Batteria supplementare ECO start/stop



Airbag



Generatore di gas



Pretensionatore



Centralina di comando sistemi di ritenuta



Protezione pedoni



Ammortizzatore pneumatico



Serbatoio carburante



Batteria



Mercedes-Benz

Classe GLK fuoristrada tipo 204 a partire da 2008

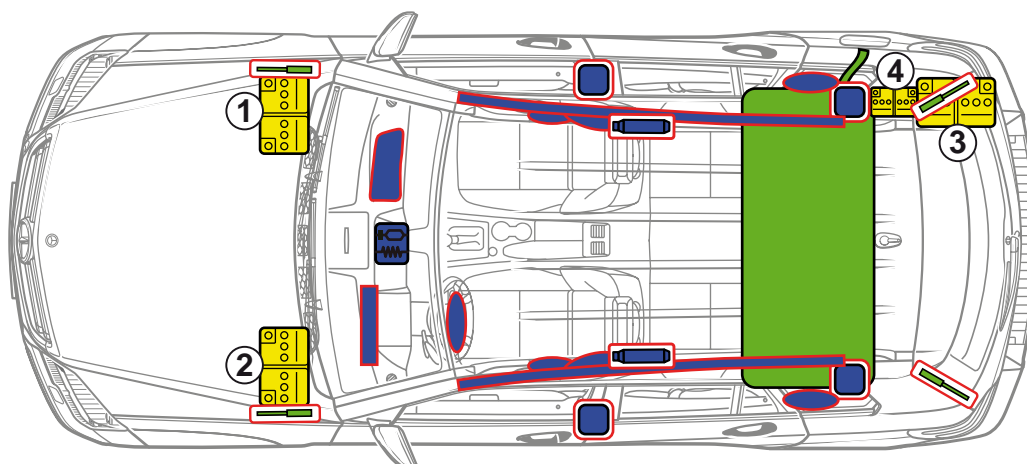
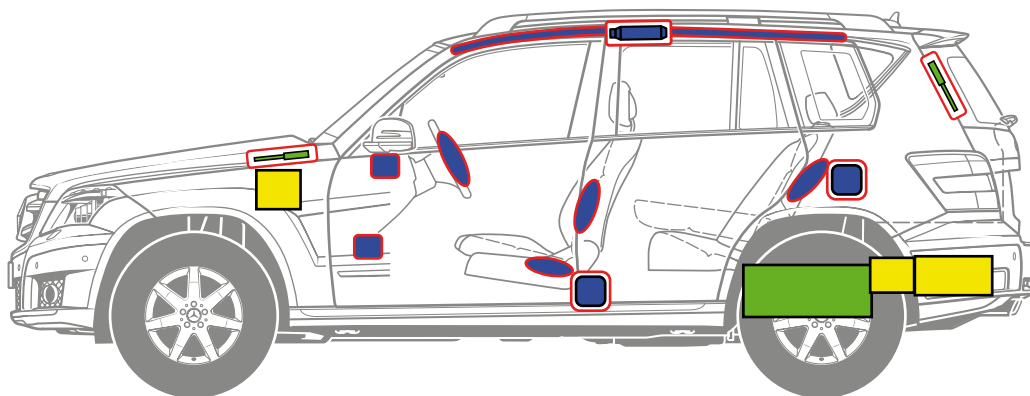
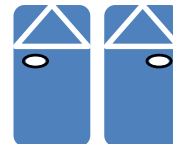

- 1 Batteria rete di bordo in caso di motore a benzina, a partire da 1.12.2009 in caso di motore diesel a 4 o 6 cilindri, veicolo con guida a sinistra
- 2 Batteria rete di bordo in caso di motore a benzina, a partire da 1.12.2009 in caso di motore diesel a 4 o 6 cilindri, veicolo con guida a destra
- 3 Batteria rete di bordo in caso di motore diesel a 6 cilindri, fino a 30.11.2009 in caso di motore diesel a 4 o 6 cilindri
- 4 Batteria supplementare ECO start/stop



Airbag



Generatore di gas



Pretensionatore



Centralina di comando sistemi di ritenuta



Ammortizzatore pneumatico



Serbatoio carburante



Batteria



Mercedes-Benz

Classe M fuoristrada
tipo 163
1997 - 2005

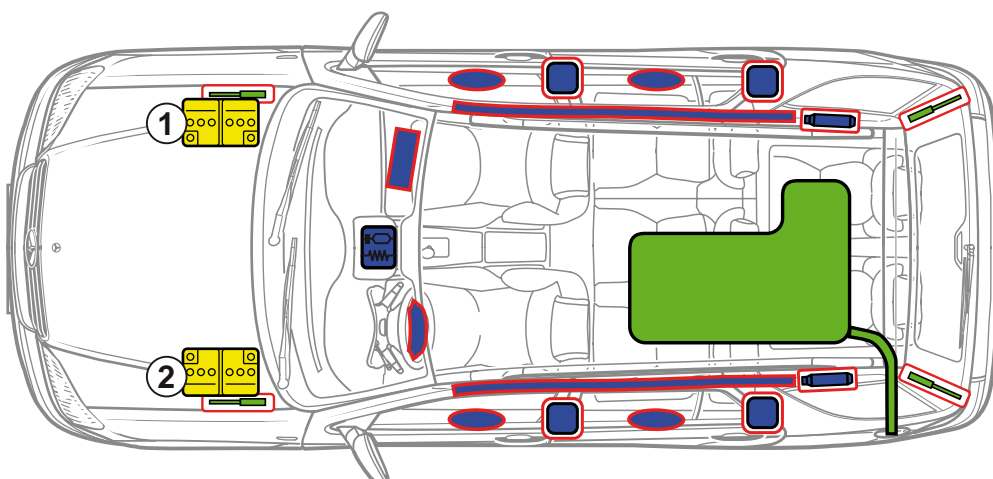
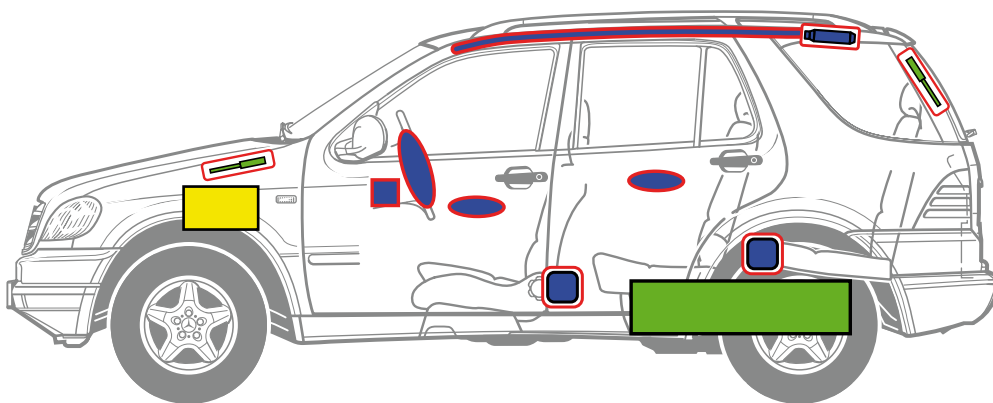
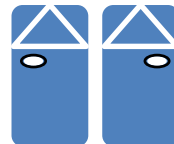

- 1 Veicolo con guida a sinistra
- 2 Veicolo con guida a destra



Airbag



Generatore di gas



Pretensionatore



Centralina di comando sistemi di ritenuta

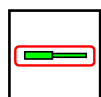

Ammortizzatore pneumatico



Serbatoio carburante



Batteria



Mercedes-Benz

Classe M fuoristrada
tipo 164
2005 - 2011

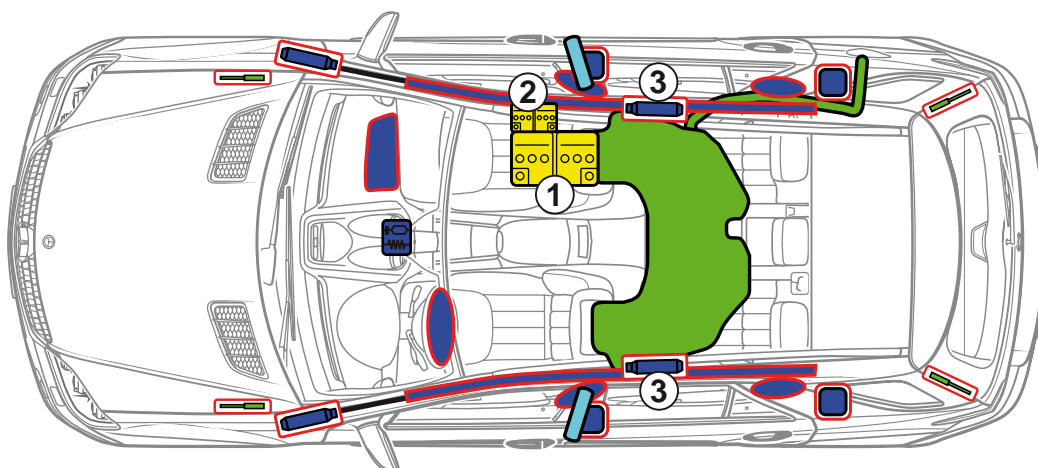
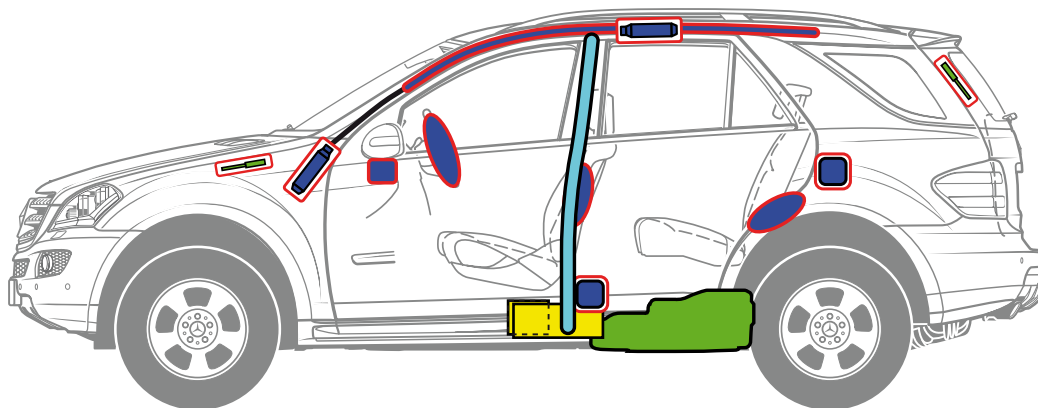

- 1 Batteria principale
- 2 Batteria supplementare
- 3 A partire dall'anno di produzione 2008



Airbag



Generatore di gas



Pretensionatore



Centralina di comando sistemi di ritenuta



Ammortizzatore pneumatico



Rinforzo carrozzeria



Serbatoio carburante



Batteria



Mercedes-Benz

Classe M HYBRID fuoristrada tipo 164 a partire da 2009

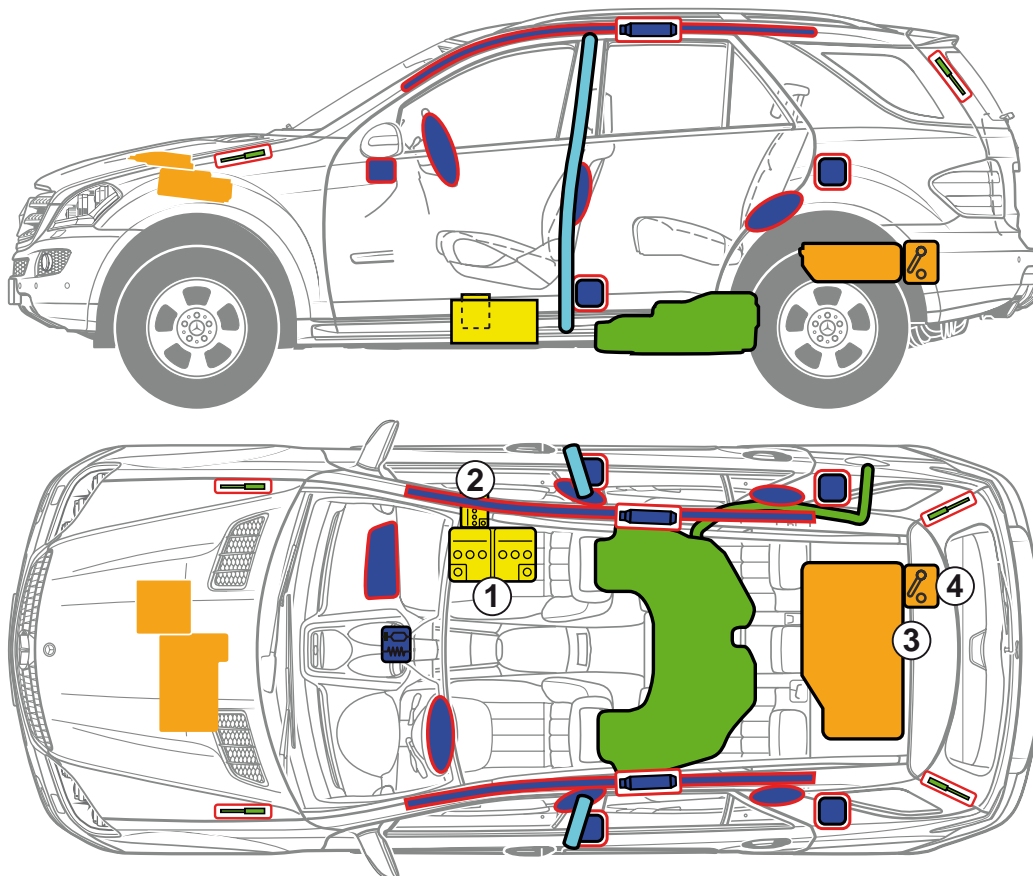

- 1 A partire da 2009
- 2 Batteria supplementare (12 V)
- 3 Batteria ad alto voltaggio
- 4 Dispositivo di disinserimento alto voltaggio

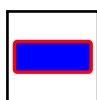

Airbag

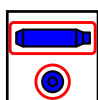

Generatore di gas

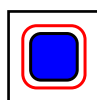

Pretensionatore

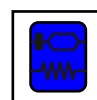

Centralina di comando sistemi di ritenuta



Ammortizzatore pneumatico

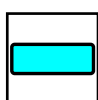

Rinforzo carrozzeria

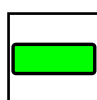

Serbatoio carburante

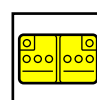

Batteria 12 V

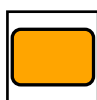

Batteria ad alto voltaggio



Componenti per l'alto voltaggio



Dispositivo di disinserimento alto voltaggio



Dispositivo di disinserimento alto voltaggio

Il dispositivo di disinserimento alto voltaggio si trova in direzione di marcia nella parte posteriore destra sulla batteria ad alto voltaggio.

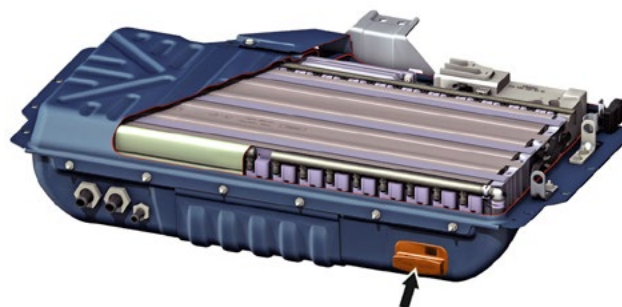

Dispositivo di disinserimento alto voltaggio

Sollevare il fondo del vano di carico (1) / Rimuovere la copertura (2) / Spingere l'interruttore (3) verso destra e staccarlo dalla batteria ad alto voltaggio

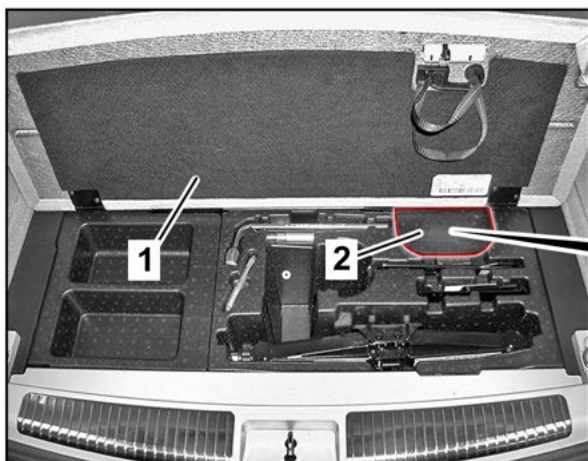

Identificazione veicolo



Parafango destro

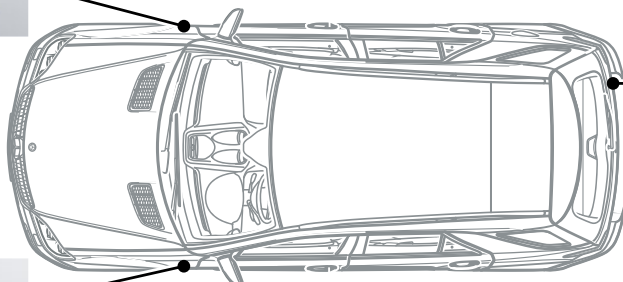

Portellone posteriore lato destro



Parafango sinistro



Mercedes-Benz

Classe M fuoristrada
tipo 166
a partire da 2011

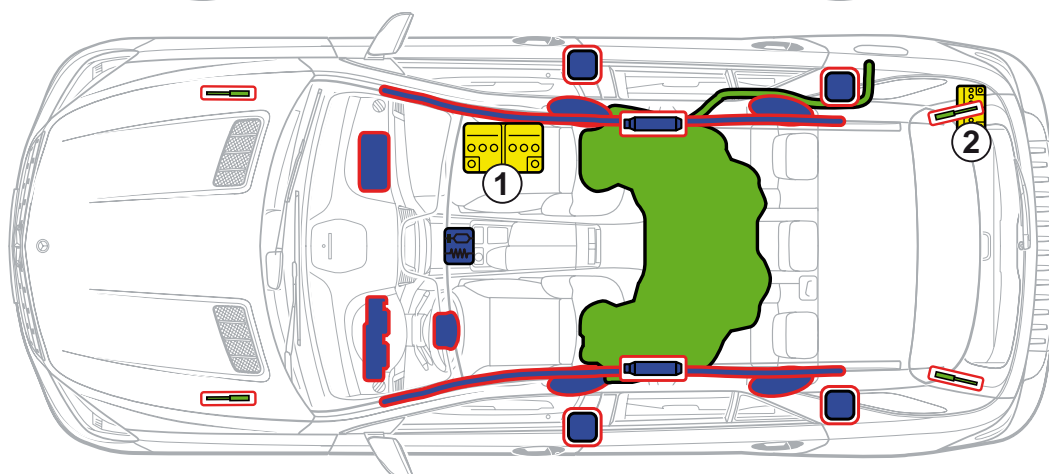
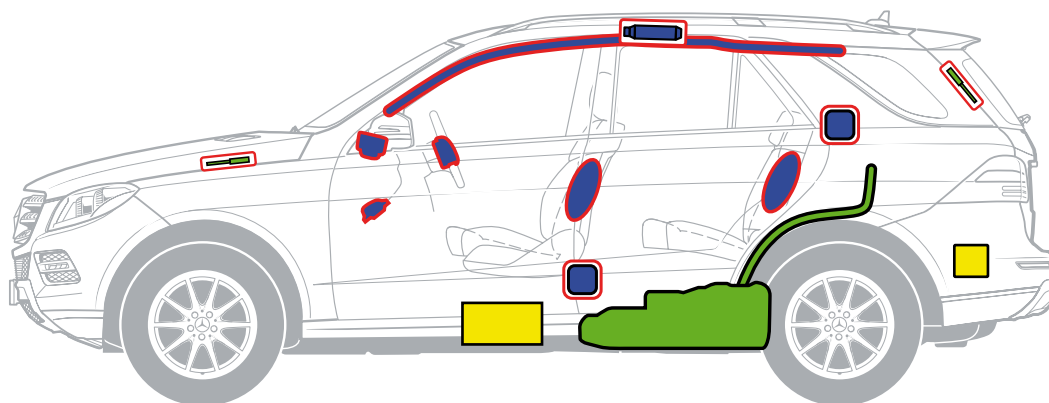

- 1 Batteria principale
- 2 Batteria supplementare

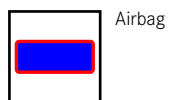

Airbag

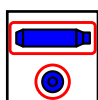

Generatore di gas

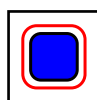

Pretensionatore

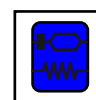

Centralina di comando
sistemi di ritenuta

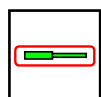

Ammortizzatore
pneumatico



Serbatoio carburante



Batteria



Mercedes-Benz

Classe GL fuoristrada
tipo 164
2006 - 2012

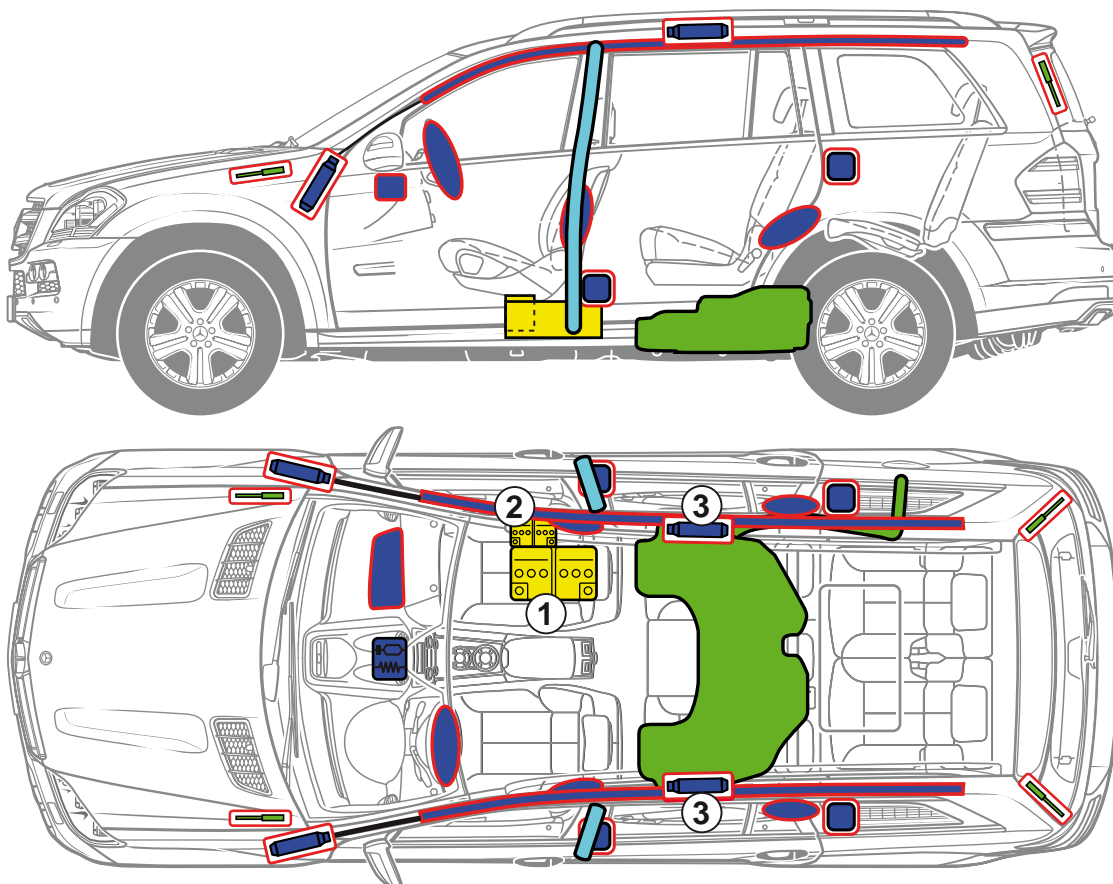

- 1 Batteria principale
- 2 Batteria supplementare
- 3 A partire dall'anno di produzione 2008

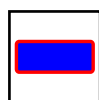

Airbag

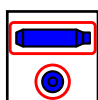

Generatore di gas

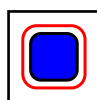

Pretensionatore

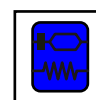

Centralina di comando sistemi di ritenuta

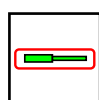

Ammortizzatore pneumatico

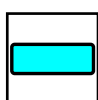

Rinforzo carrozzeria

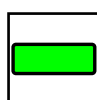

Serbatoio carburante

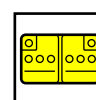

Batteria



Mercedes-Benz

Classe GL fuoristrada
tipo 166
a partire da 2012

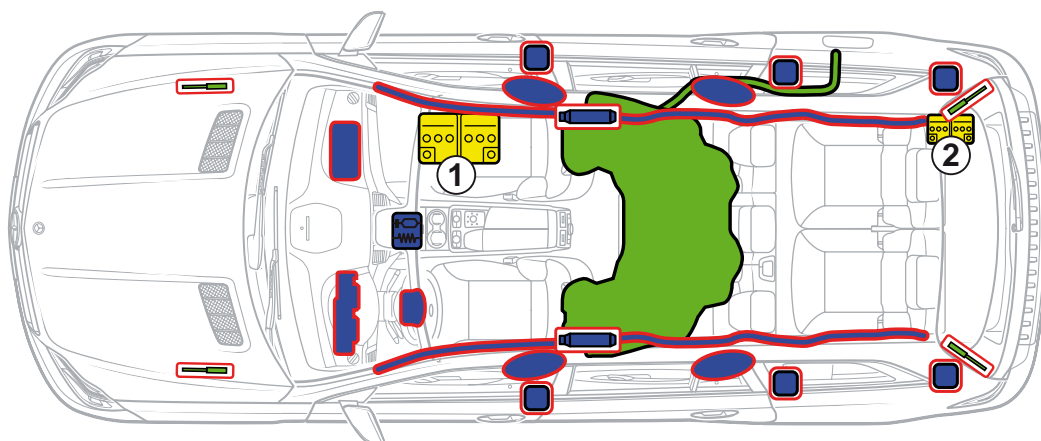
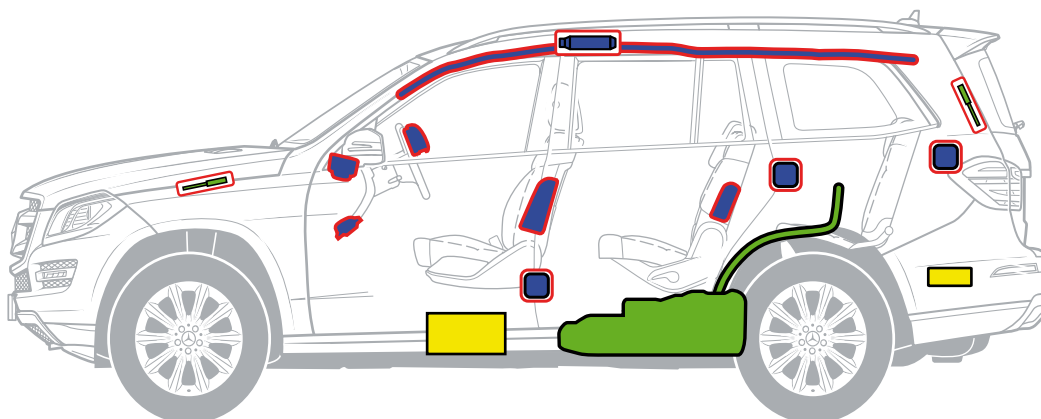

- 1 Batteria principale
- 2 Batteria supplementare

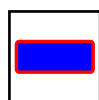

Airbag

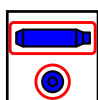

Generatore di gas

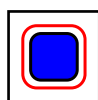

Pretensionatore

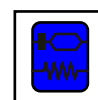

Centralina di comando
sistemi di ritenuta



Ammortizzatore
pneumatico



Serbatoio carburante



Batteria



Mercedes-Benz

Vaneo
tipo 414
2002 - 2005

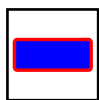
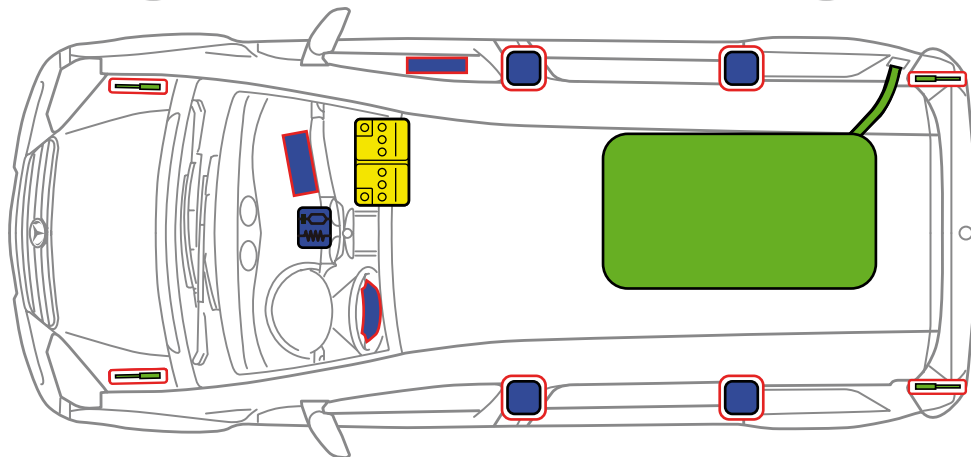
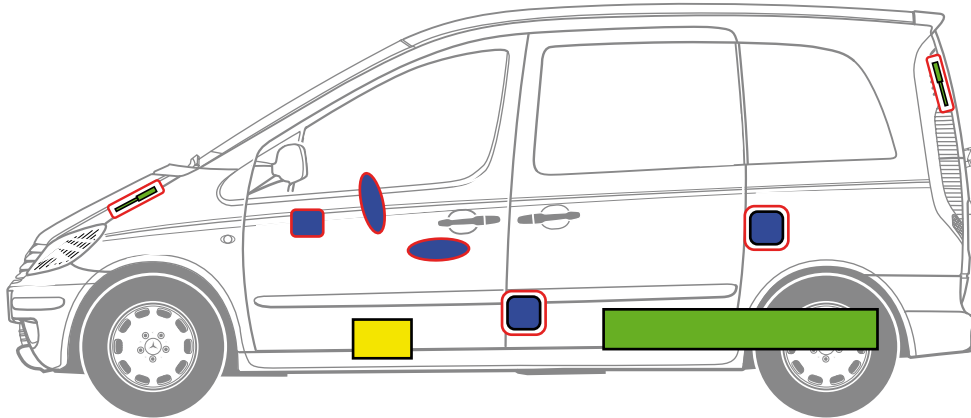

Airbag

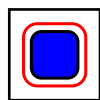

Pretensionatore

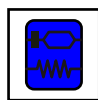

Centralina di comando
sistemi di ritenuta



Ammortizzatore
pneumatico



Serbatoio carburante

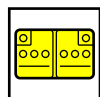

Batteria



Mercedes-Benz

Citan Kombi tipo 415 a partire da 2012

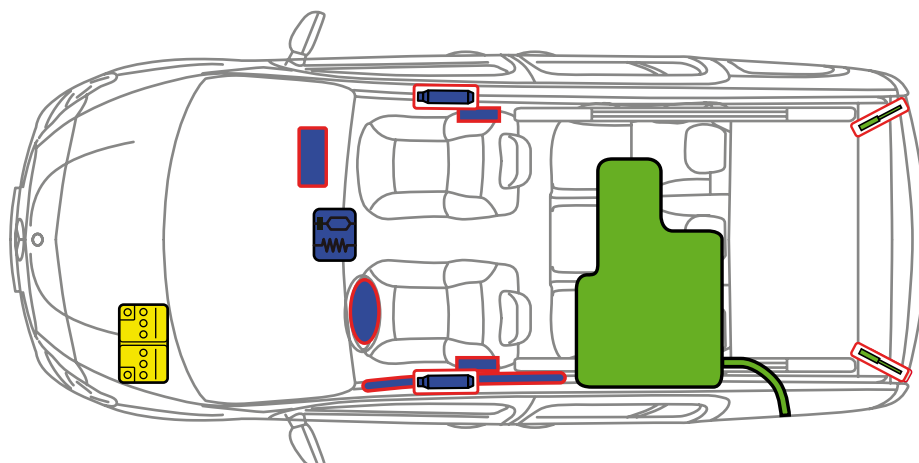
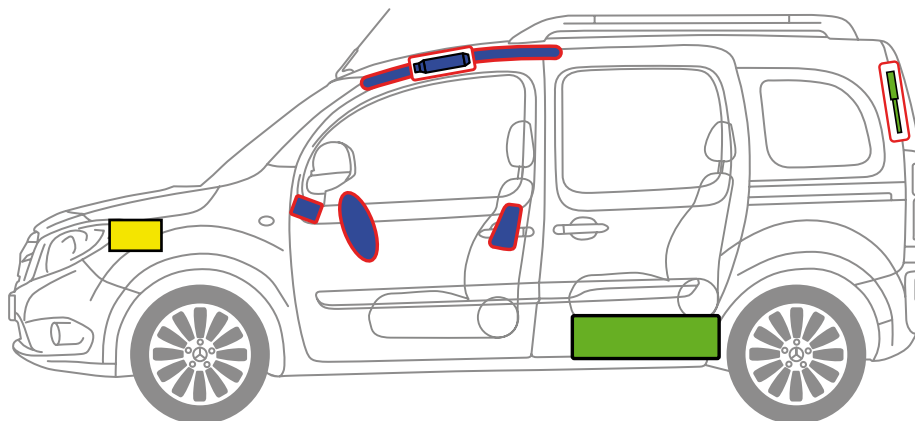

Airbag



Generatore di gas



Pretensionatore



Centralina di comando sistemi di ritenuta



Ammortizzatore pneumatico



Serbatoio carburante



Batteria



Mercedes-Benz

Classe V Vito
tipo 638
1996 - 2003

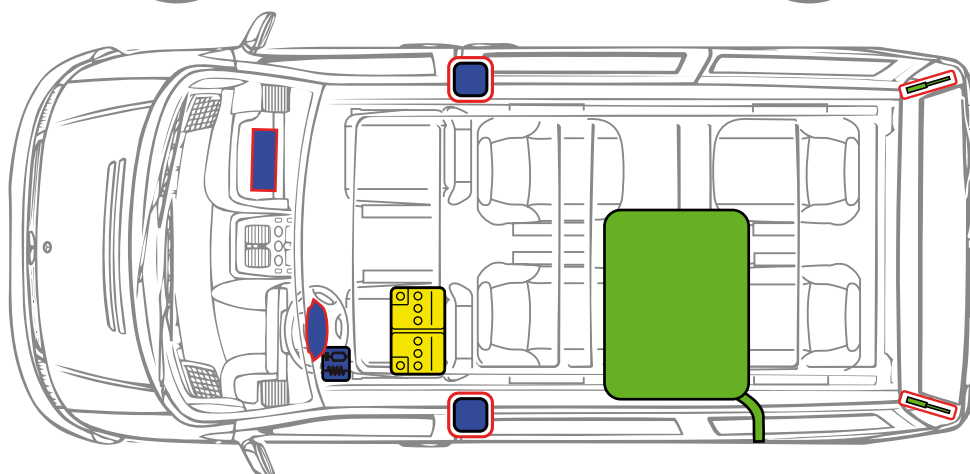
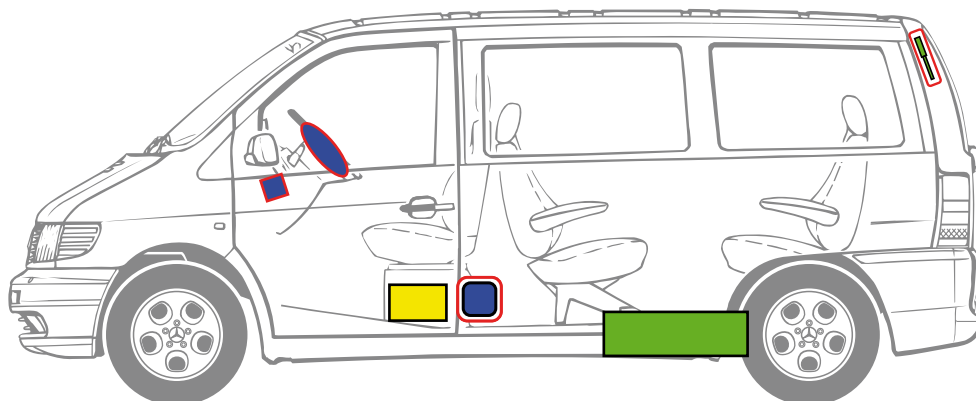

Airbag



Pretensionatore



Centralina di comando
sistemi di ritenuta



Ammortizzatore
pneumatico



Serbatoio carburante



Batteria



Mercedes-Benz

Viano / Vito
tipo 639
2003 - 2014

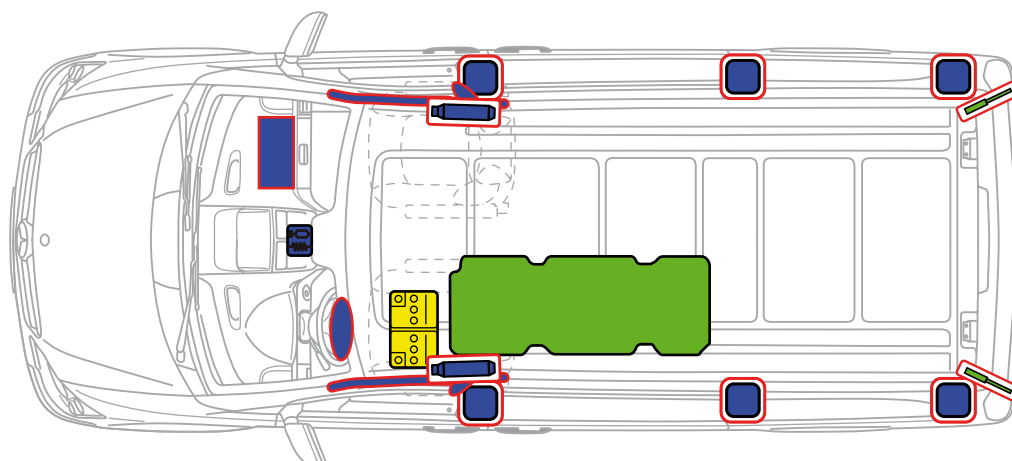
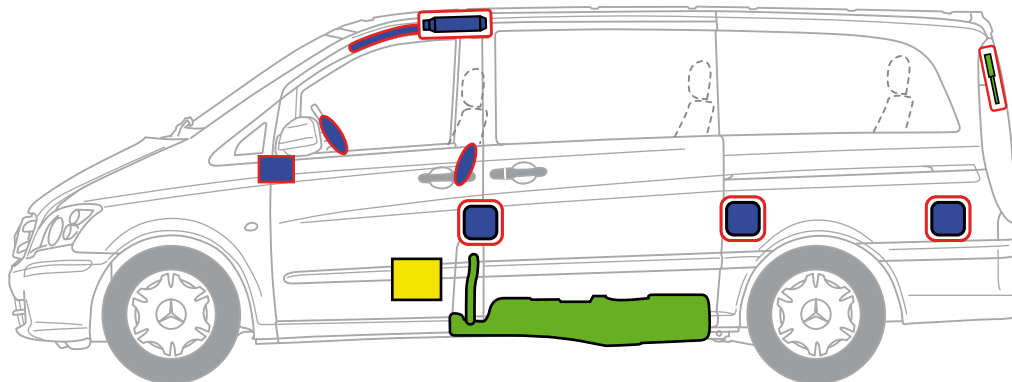

Airbag



Generatore di gas



Pretensionatore



Centralina di comando
sistemi di ritenuta



Ammortizzatore
pneumatico



Serbatoio carburante



Batteria



Mercedes-Benz

Classe V Kombi
tipo 447
a partire da 2014

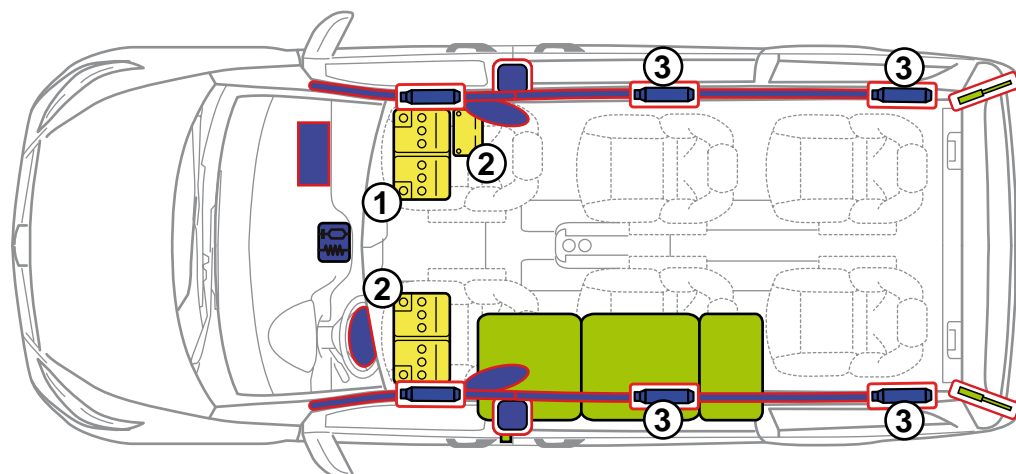
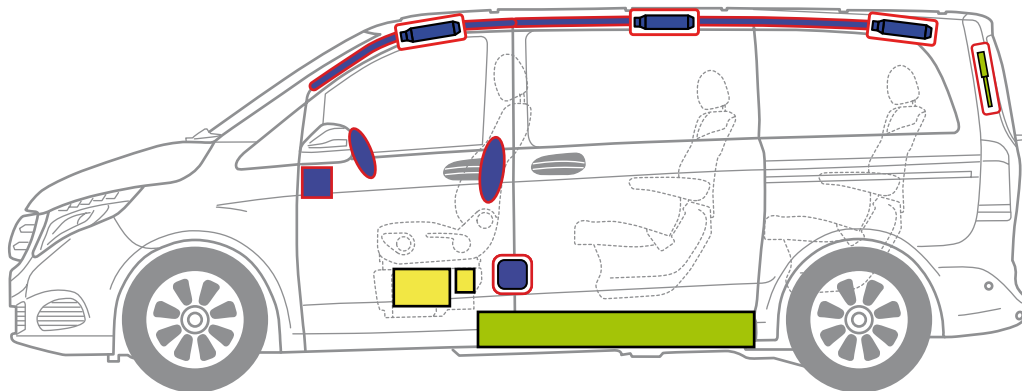

- 1 Batteria principale
- 2 Batteria supplementare
- 3 Equipaggiamento speciale



Airbag



Generatore di gas



Pretensionatore



Centralina di comando sistemi di ritenuta



Ammortizzatore pneumatico



Serbatoio carburante



Batteria



Mercedes-Benz

Viano FUN Camper tipo 639 a partire da 2003

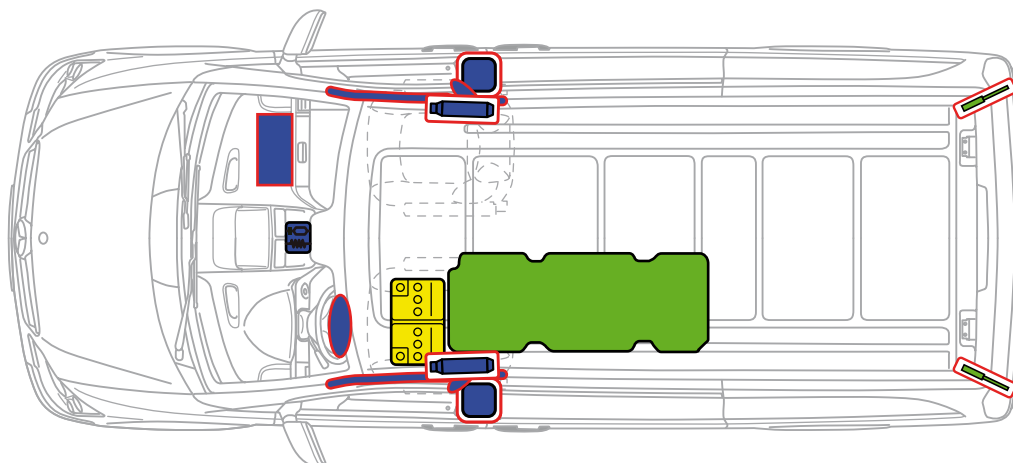
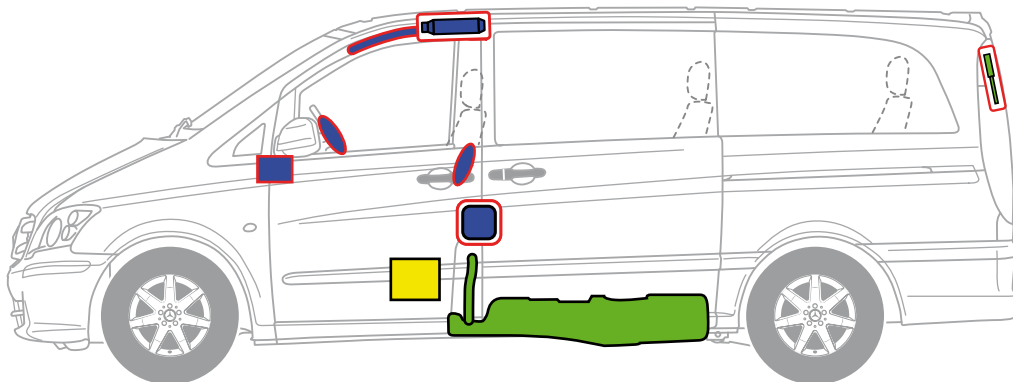

Airbag



Generatore di gas



Pretensionatore



Centralina di comando sistemi di ritenuta



Ammortizzatore pneumatico



Serbatoio carburante



Batteria



Mercedes-Benz

Viano MARCO POLO Camper tipo Typ 639 a partire da 2003

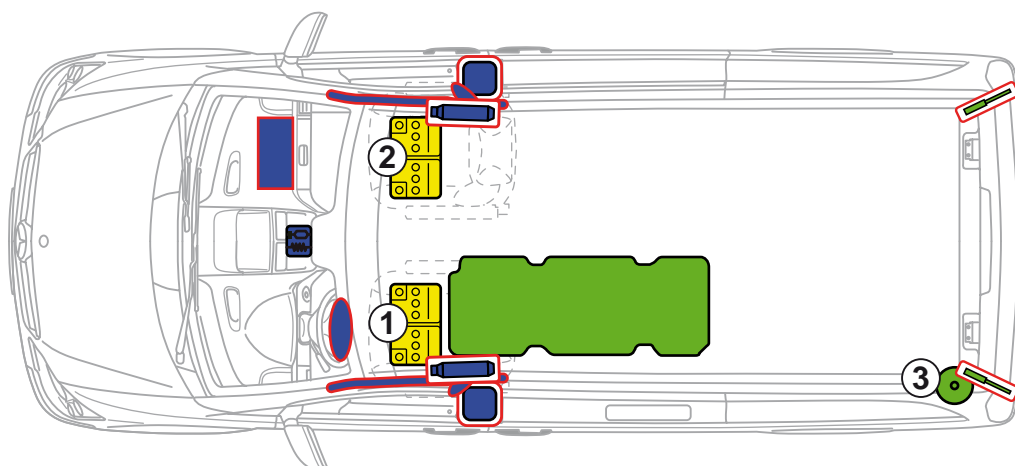
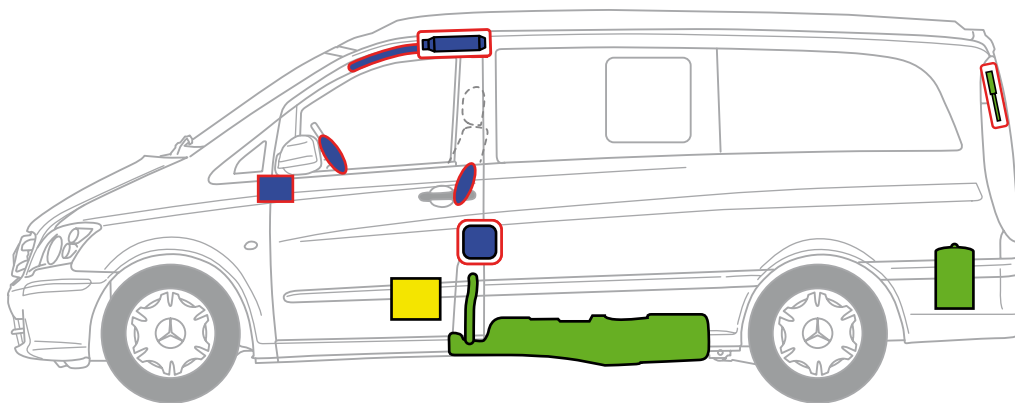

- 1 Batteria principale
- 2 Batteria supplementare
- 3 Bombola del gas (Campingaz, 2,8 kg)

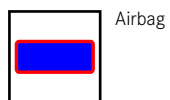

Airbag

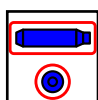

Generatore di gas

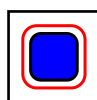

Pretensionatore

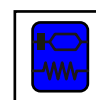

Centralina di comando sistemi di ritenuta

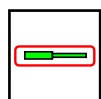

Ammortizzatore pneumatico



Serbatoio carburante



Batteria



Mercedes-Benz

Sprinter JAMES COOK (Westfalia) Camper tipo 901-905 1995 - 2006

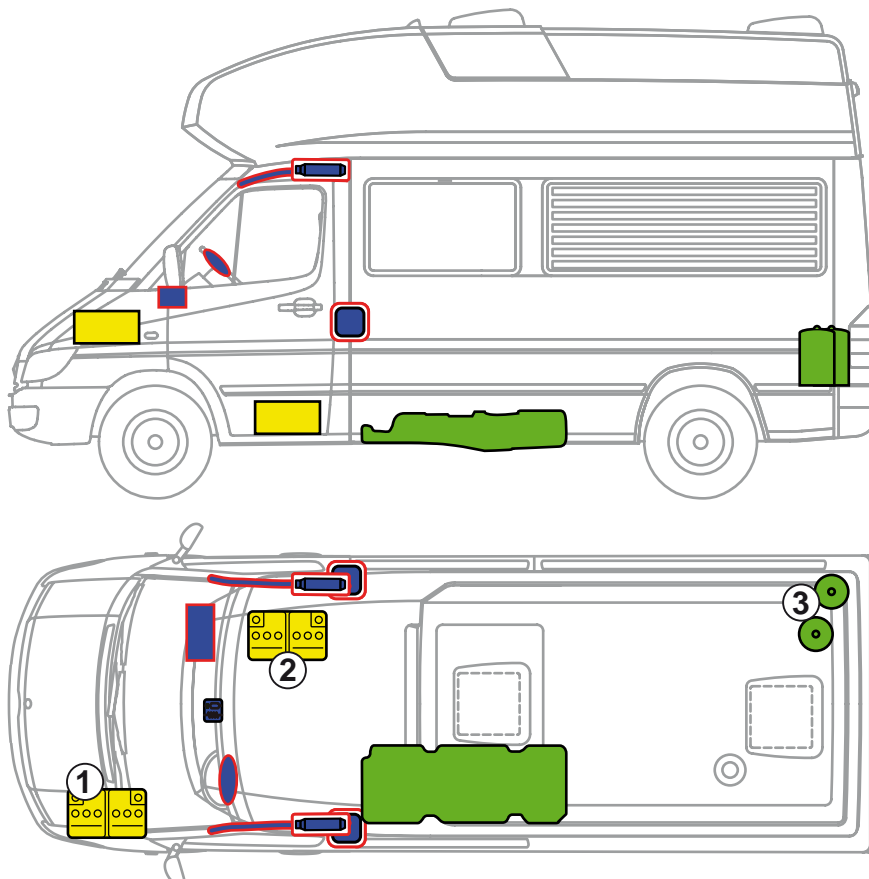

- 1 Batteria di avviamento
- 2 Batteria supplementare
- 3 Bombole del gas (Campingaz, 2x5 kg)



Airbag



Generatore di gas



Pretensionatore



Centralina di comando sistemi di ritenuta



Serbatoio carburante



Batteria



Mercedes-Benz

Sprinter JAMES COOK (Westfalia) Camper tipo 906 a partire da 2006

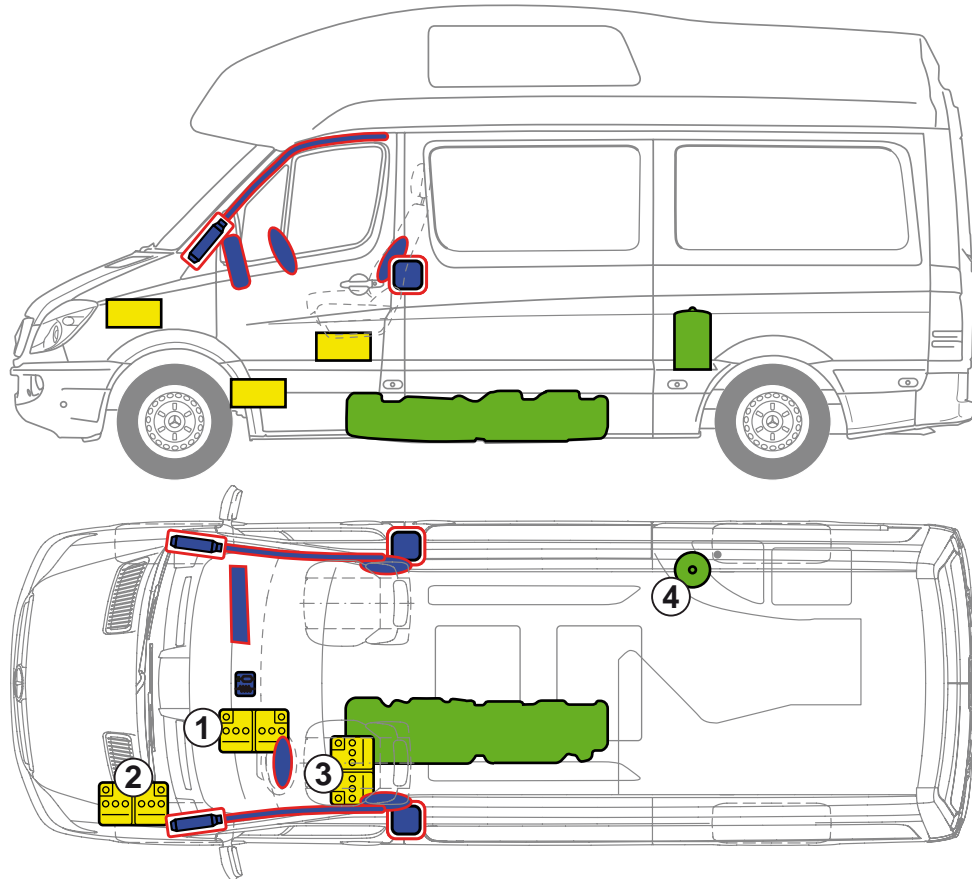
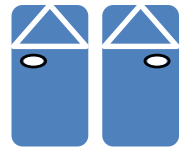

- 1 Batteria di avviamento
- 2 Batteria supplementare (veicolo con guida a sinistra)
- 3 Batteria supplementare (veicolo con guida a destra)
- 4 Bombola del gas (Campingaz, 2,75 kg)



Airbag

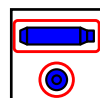

Generatore di gas



Pretensionatore



Centralina di comando sistemi di ritenuta



Serbatoio carburante

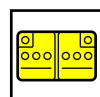

Batteria



Mercedes-Benz

SLS AMG
tipo 197
a partire da 2010

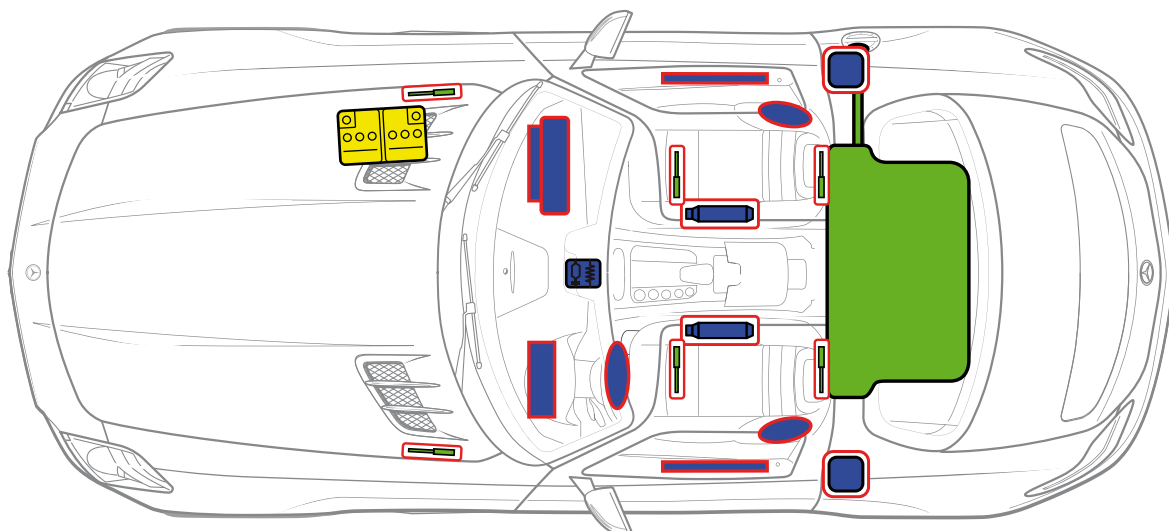
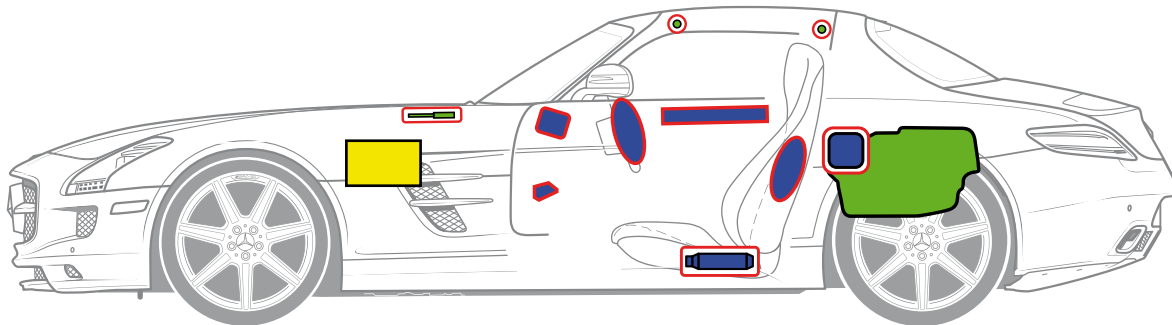

Airbag



Generatore di gas



Pretensionatore



Centralina di comando
sistemi di ritenuta



Ammortizzatore
pneumatico



Serbatoio carburante



Batteria



Mercedes-Benz

SLS AMG roadster
tipo 197
a partire da 2011

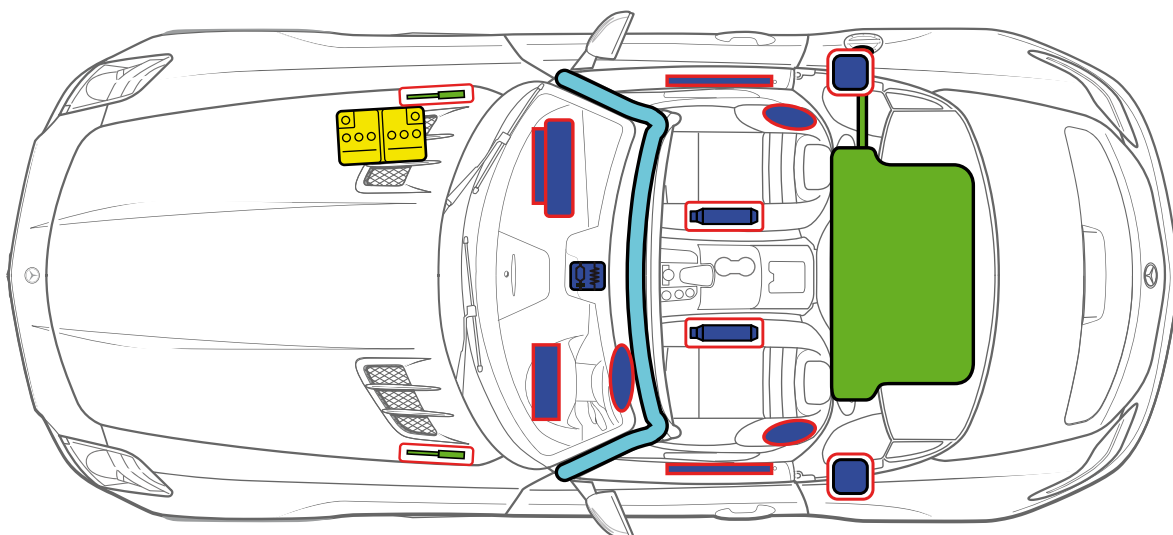
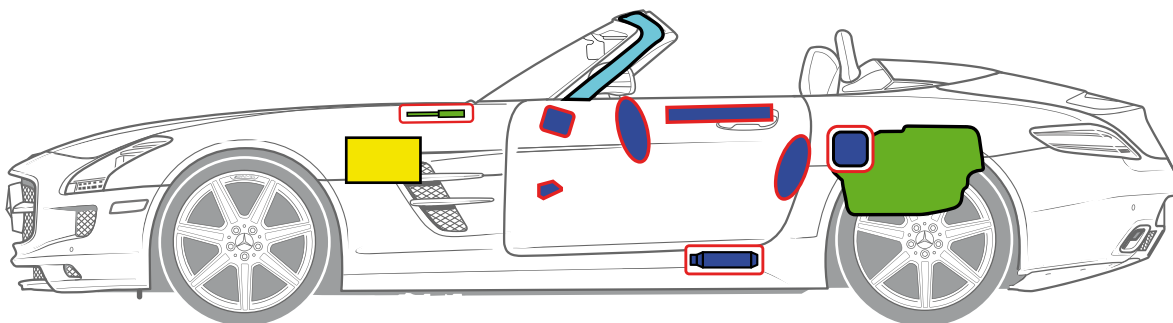

Airbag



Generatore di gas



Pretensionatore



Centralina di comando
sistemi di ritenuta

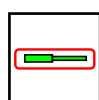

Ammortizzatore
pneumatico

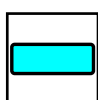

Rinforzo carrozzeria

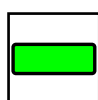

Serbatoio carburante

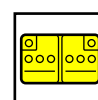

Batteria



Mercedes-Benz

SLS AMG coupé ELECTRIC DRIVE tipo 197 a partire da 2013

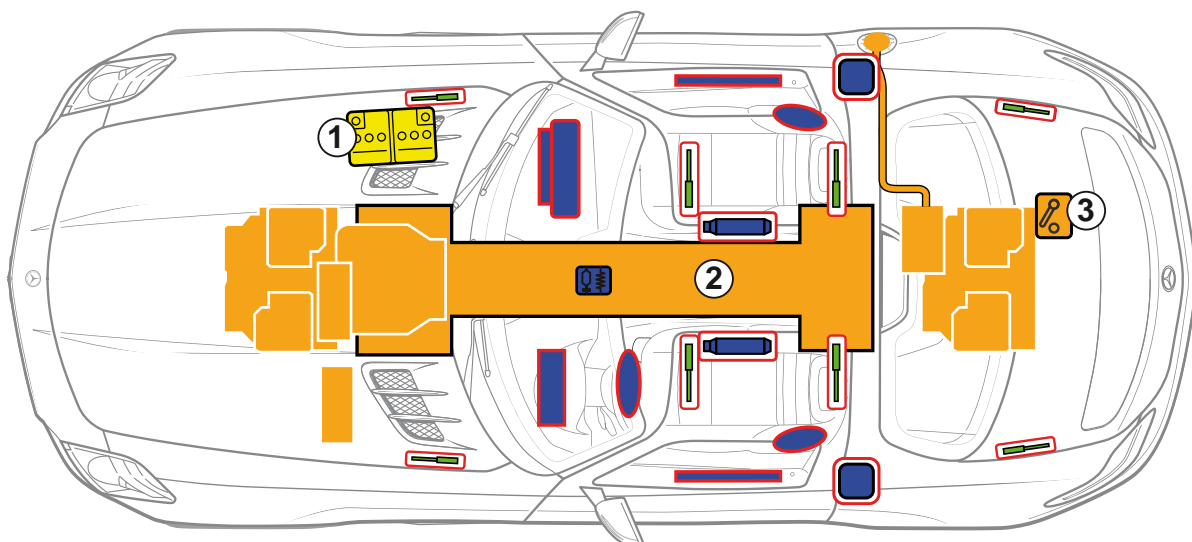
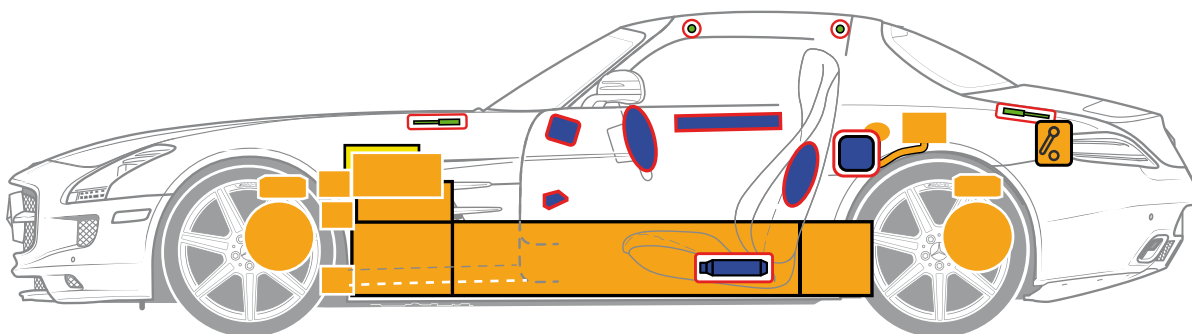

- 1 Batteria (12 V)
- 2 Batteria ad alto voltaggio
- 3 Dispositivo di disinserimento alto voltaggio

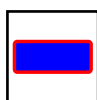

Airbag

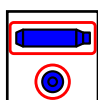

Generatore di gas

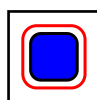

Pretensionatore

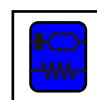

Centralina di comando sistemi di ritenuta



Ammortizzatore pneumatico



Batteria 12 V



Batteria ad alto voltaggio



Componenti per l'alto voltaggio



Dispositivo di disinserimento alto voltaggio



Dispositivo di disinserimento alto voltaggio

Sotto lo sportello di copertura della scatola fusibili e relè sulla parete posteriore nel bagagliaio si trova il dispositivo di disinserimento alto voltaggio.

Aprire lo sportello di copertura (1) / Estrarre l'interruttore (2) sulla scatola fusibili e relè (3)

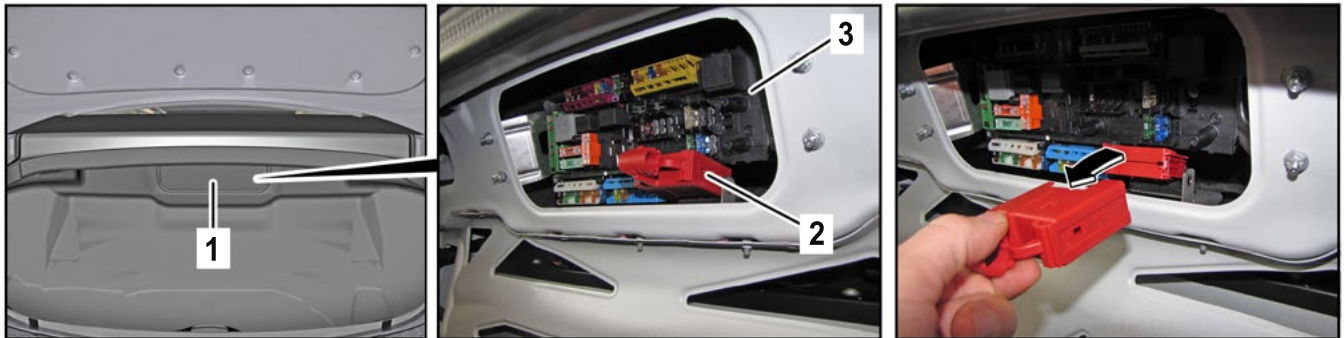

Cerniere delle porte

La SLS AMG è dotata di un sistema di sicurezza che provvede al disaccoppiamento delle cerniere delle porte dai bracci delle cerniere se la vettura dopo un incidente rimane in posizione capovolta.

In ciascuna cerniera porta (1) è disposto un dispositivo di scatto pirotecnico (2) che viene attivato dalla centralina di comando sistemi di ritenuta.

Dopo l'apertura della serratura porta le porte possono essere sfilate dai bracci delle cerniere (3).

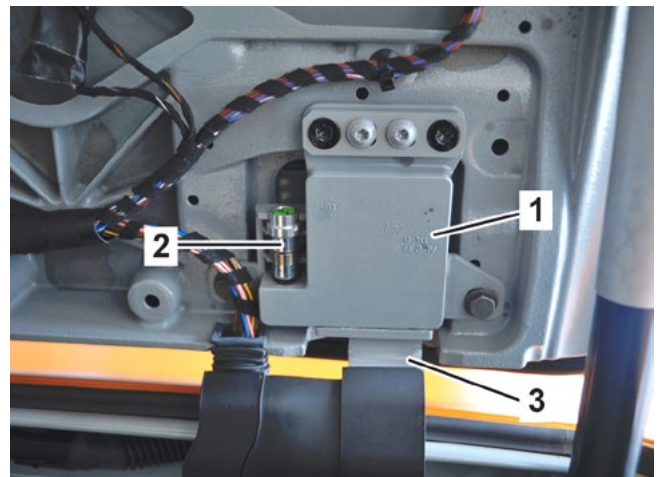

Identificazione veicolo

Presella di carica di alto voltaggio



Parafango destro

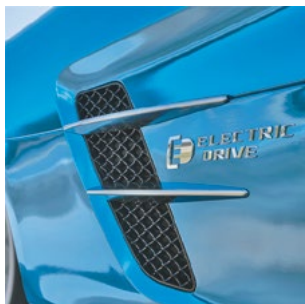



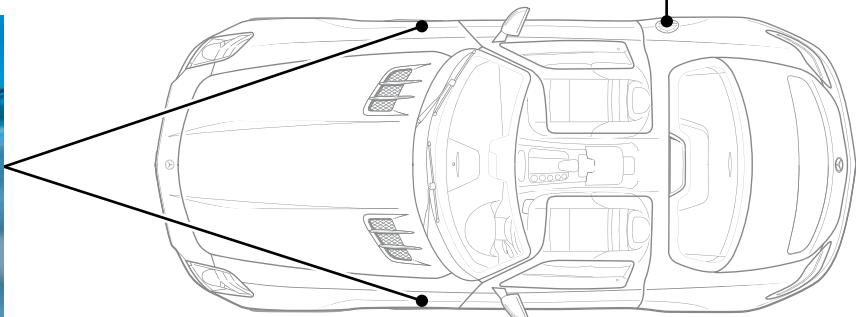

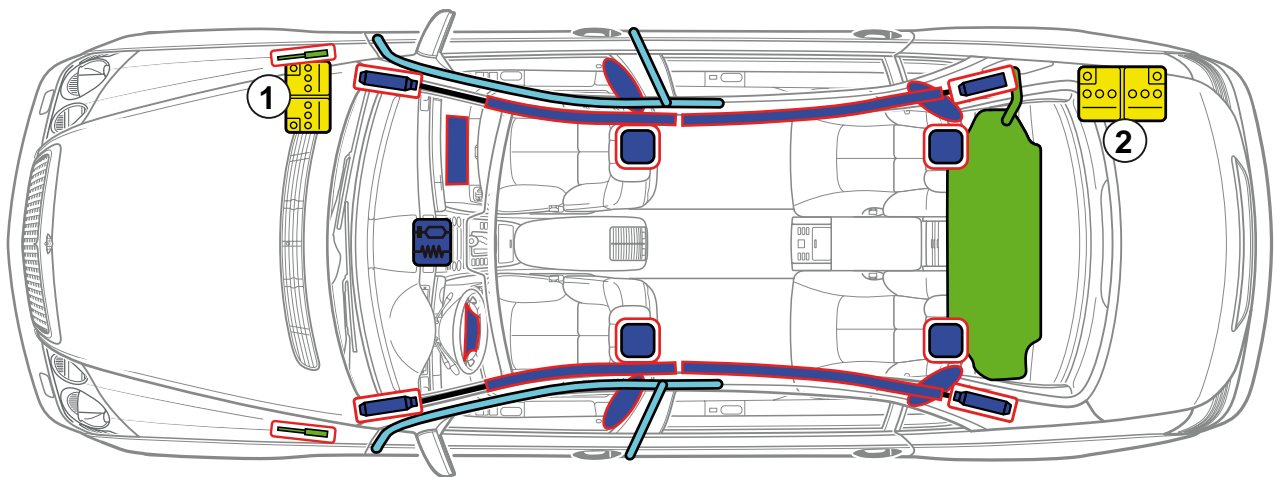
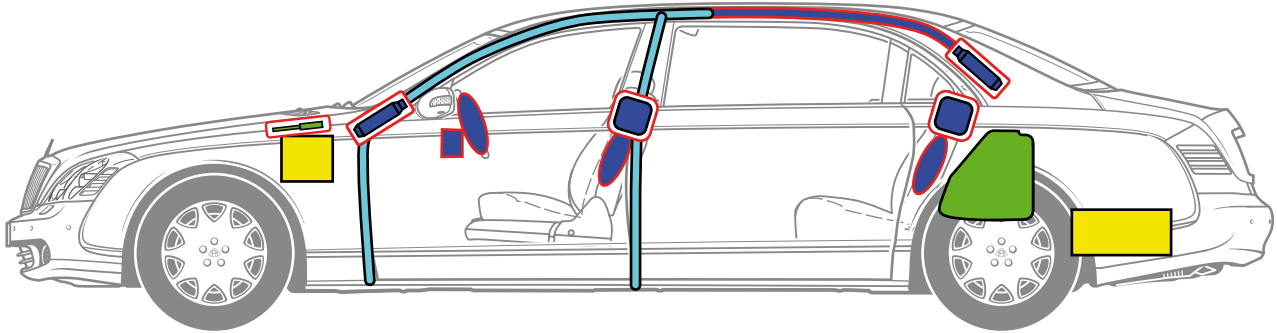



Parafango sinistro





- 1 Batteria di avviamento vano motore
- 2 Batteria rete di bordo bagagliaio

 Airbag	 Generatore di gas	 Pretensionatore	 Centralina di comando sistemi di ritenuta
 Ammortizzatore pneumatico	 Rinforzo carrozzeria	 Serbatoio carburante	 Batteria

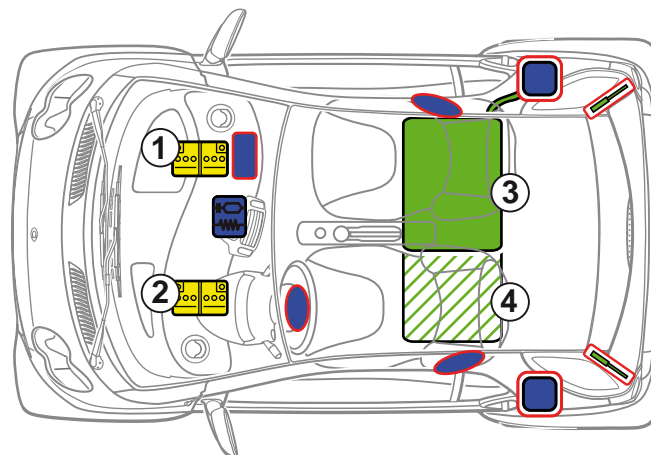
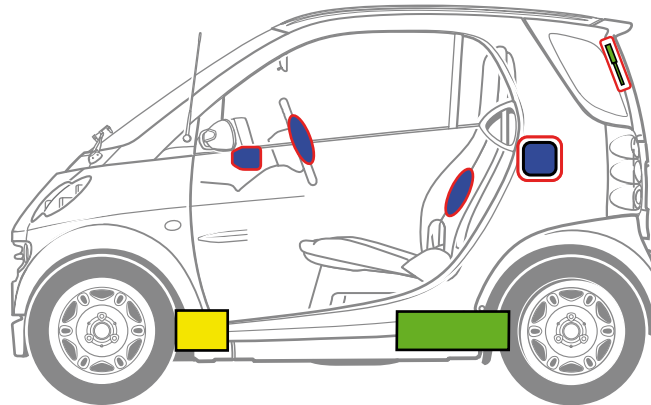
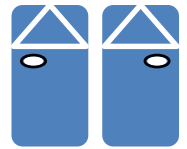

- 1 Veicolo con guida a sinistra
- 2 Veicolo con guida a destra
- 3 Serbatoio carburante motore diesel
- 4 Serbatoio carburante motore a benzina



Airbag

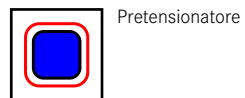

Pretensionatore

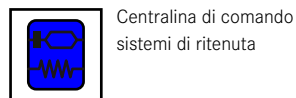

Centralina di comando sistemi di ritenuta

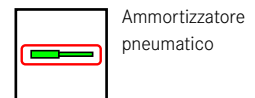

Ammortizzatore pneumatico



Serbatoio carburante

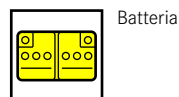

Batteria

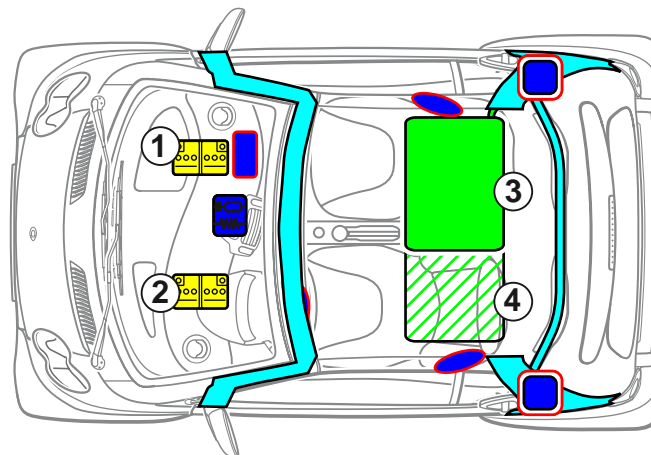
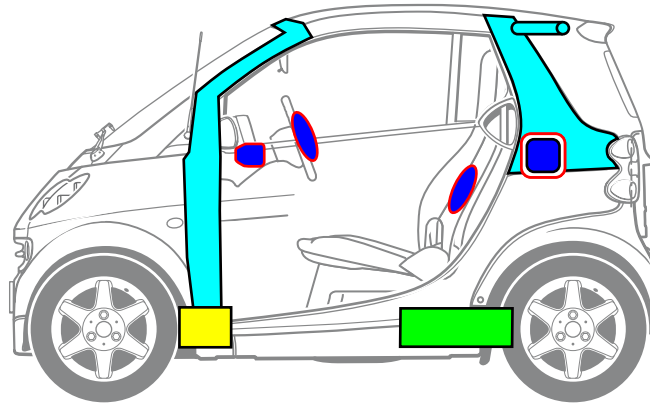
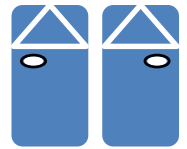

- 1 Veicolo con guida a sinistra
- 2 Veicolo con guida a destra
- 3 Serbatoio carburante motore diesel
- 4 Serbatoio carburante motore a benzina



Airbag

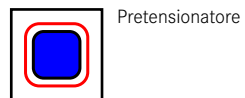

Pretensionatore

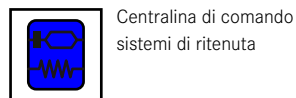

Centralina di comando sistemi di ritenuta

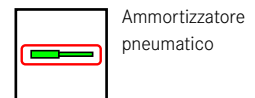

Ammortizzatore pneumatico



Rinforzo carrozzeria

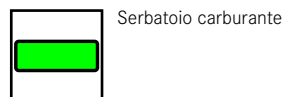

Serbatoio carburante

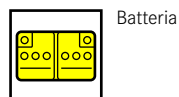

Batteria

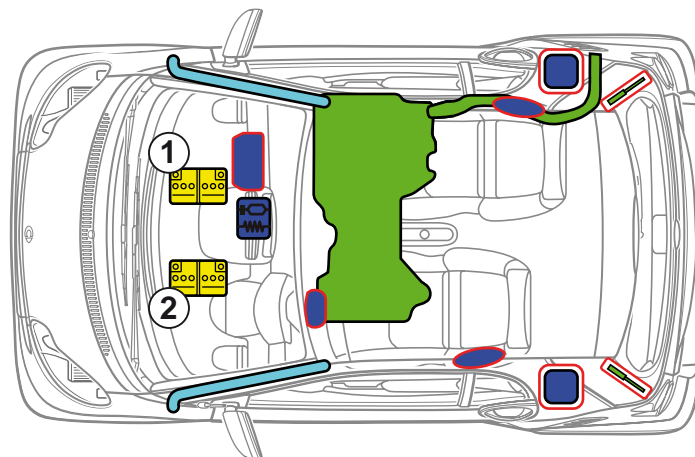
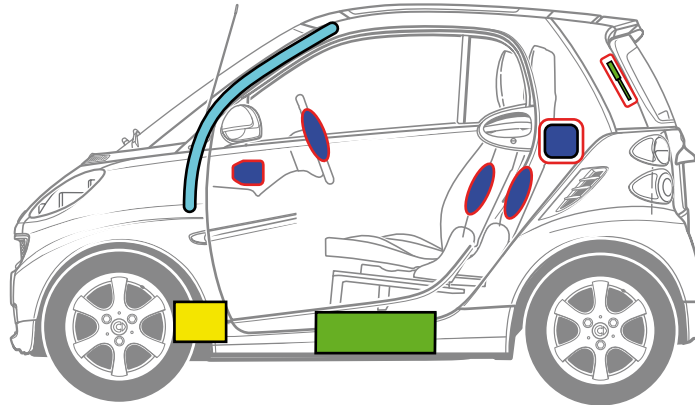
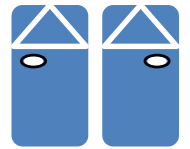

- 1 Veicolo con guida a sinistra
- 2 Veicolo con guida a destra

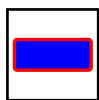

Airbag

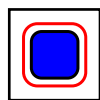

Pretensionatore

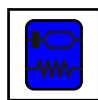

Centralina di comando sistemi di ritenuta



Ammortizzatore pneumatico



Rinforzo carrozzeria

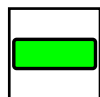

Serbatoio carburante



Batteria

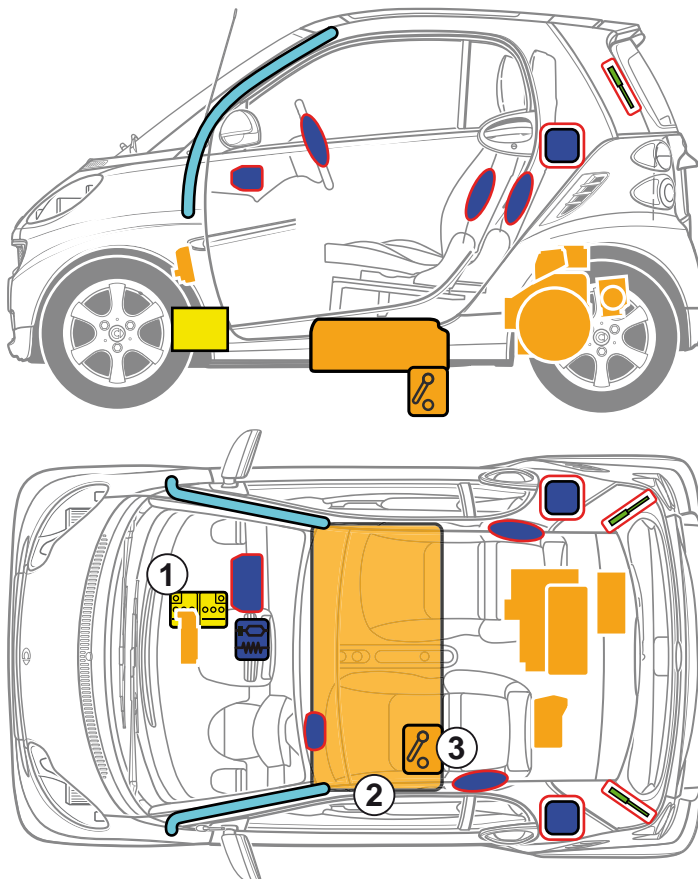

- 1 Batteria (12 V)
- 2 Batteria ad alto voltaggio
- 3 Dispositivo di disinserimento alto voltaggio

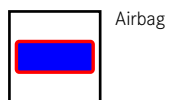

Airbag

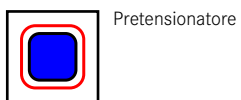

Pretensionatore

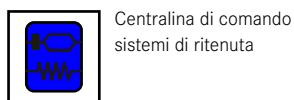

Centralina di comando sistemi di ritenuta

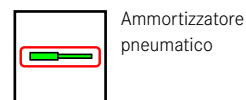

Ammortizzatore pneumatico



Rinforzo carrozzeria

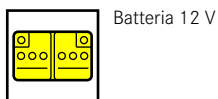

Batteria 12 V

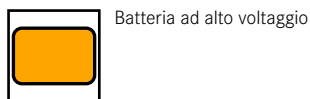

Batteria ad alto voltaggio



Componenti per l'alto voltaggio

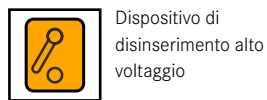

Dispositivo di disinserimento alto voltaggio



Identificazione veicolo

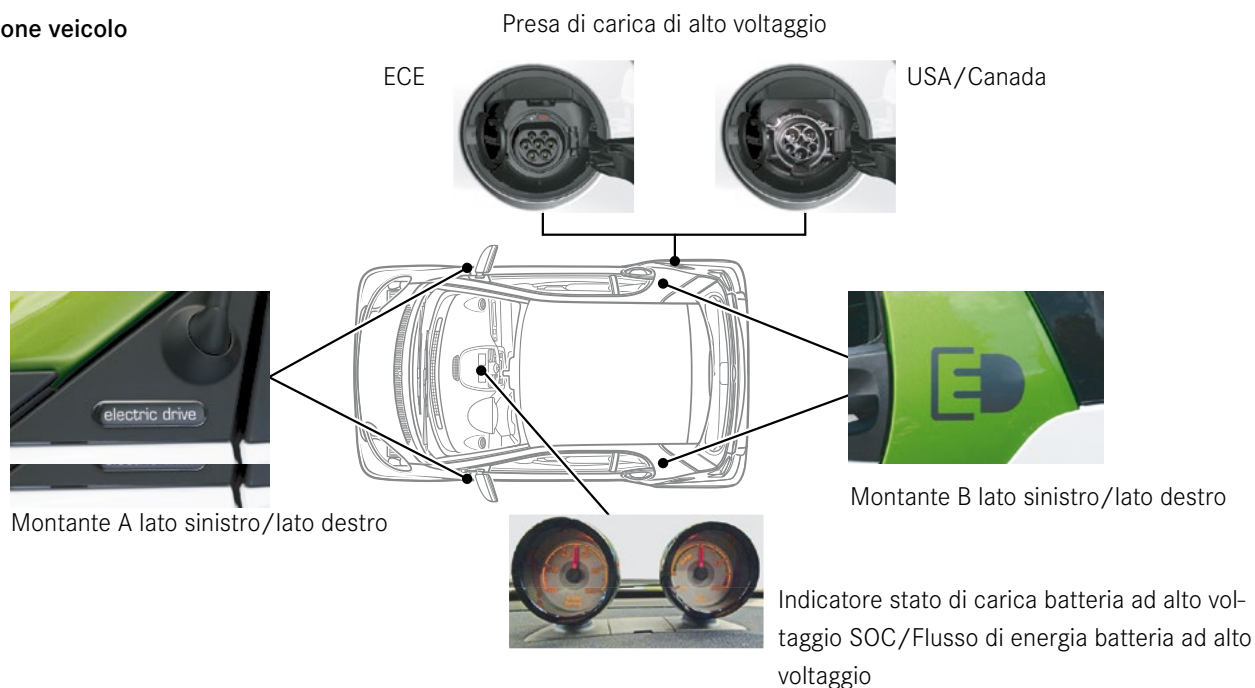

Dispositivo di disinserimento alto voltaggio

Il dispositivo di disinserimento alto voltaggio si trova sul lato inferiore della batteria ad alto voltaggio in direzione di marcia nella parte posteriore sinistra.

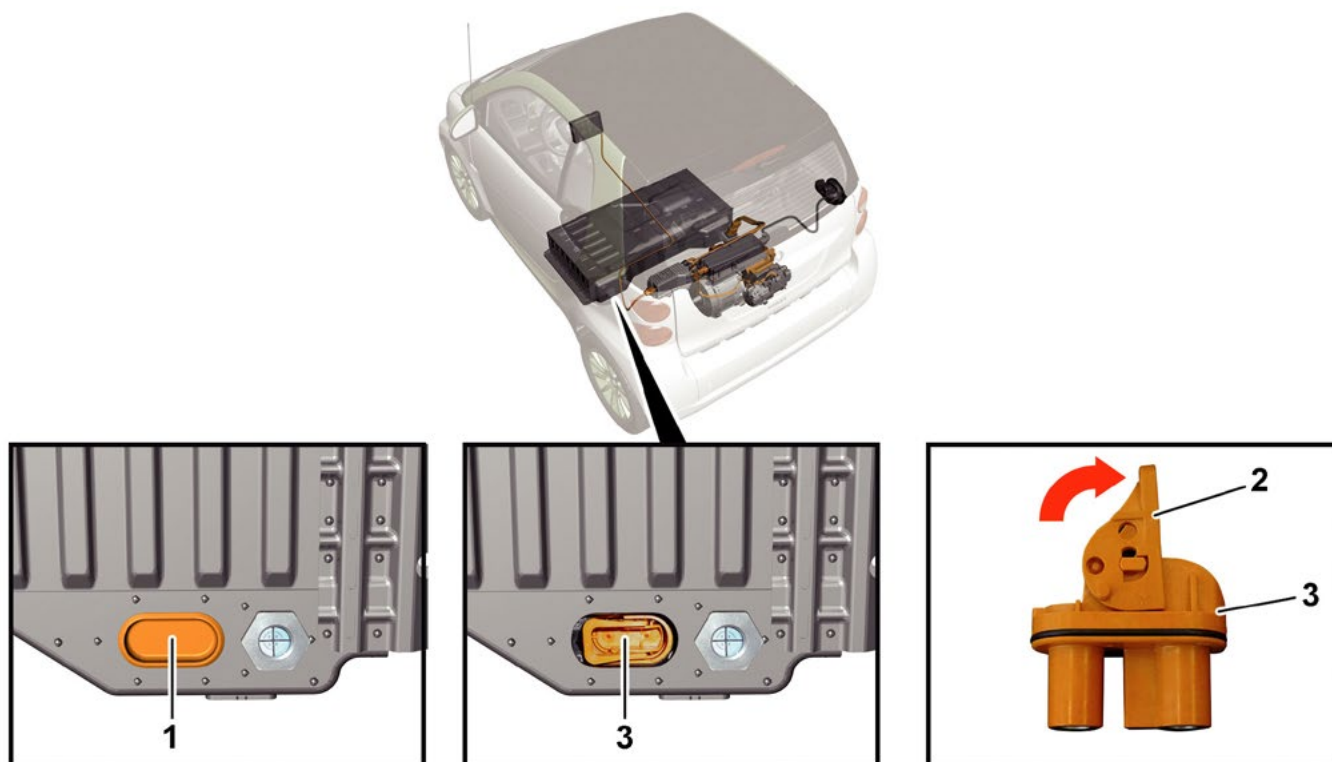

Rimuovere la copertura (1) / Aprire il bloccaggio (2) sul connettore a spina (3) / Estrarre il connettore a spina (3) dalla batteria ad alto voltaggio

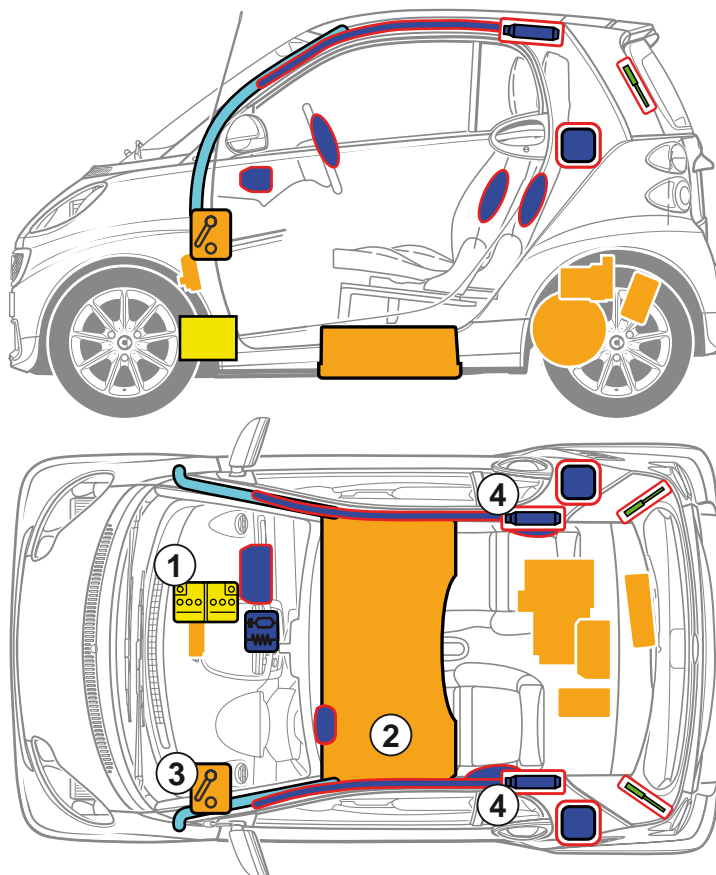

- 1 Batteria (12 V)
- 2 Batteria ad alto voltaggio
- 3 Dispositivo di disinserimento alto voltaggio
- 4 Windowbag (solo USA)

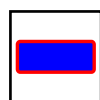

Airbag

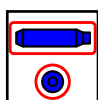

Generatore di gas

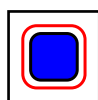

Pretensionatore

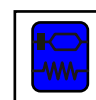

Centralina di comando sistemi di ritenuta

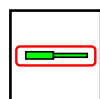

Ammortizzatore pneumatico



Rinforzo carrozzeria



Batteria 12 V



Batteria ad alto voltaggio



Componenti per l'alto voltaggio



Dispositivo di disinserimento alto voltaggio



Identificazione veicolo

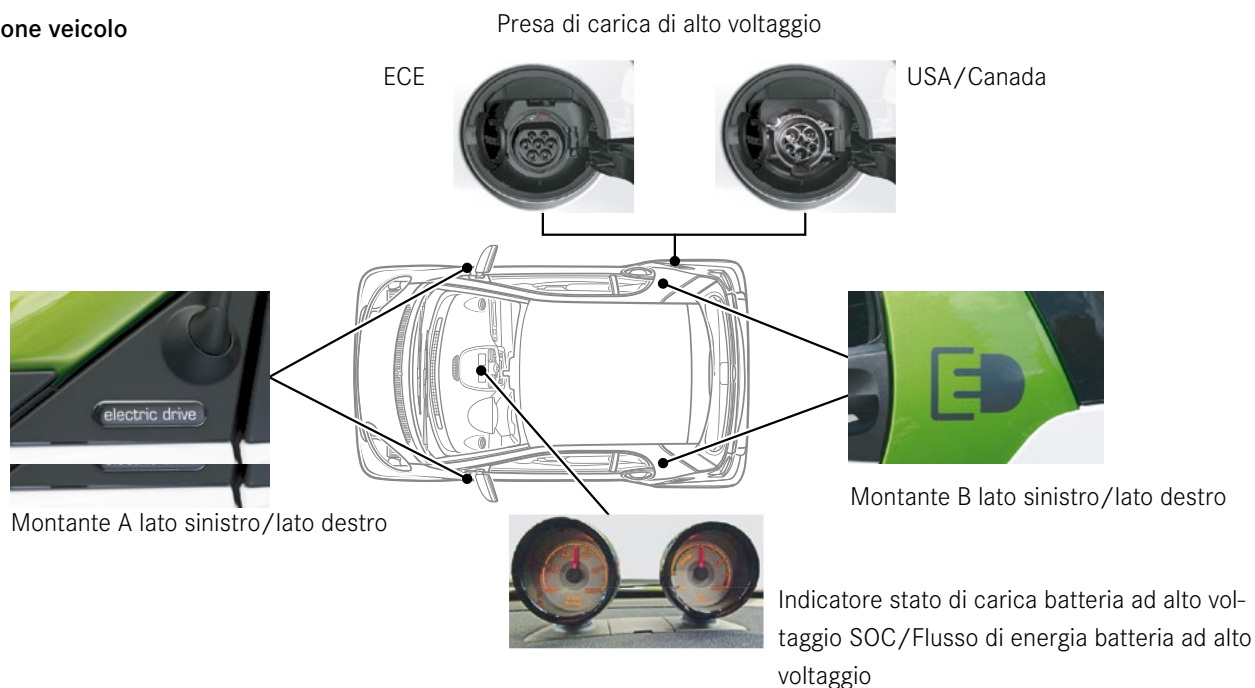

Dispositivo di disinserimento alto voltaggio

Il dispositivo di disinserimento alto voltaggio si trova sul lato inferiore della plancia portastrumenti in direzione di marcia a sinistra.



Estrarre il connettore a spina (1) dal supporto

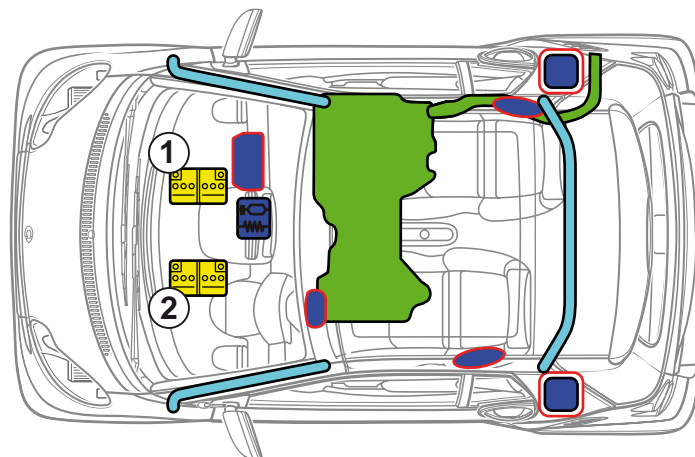
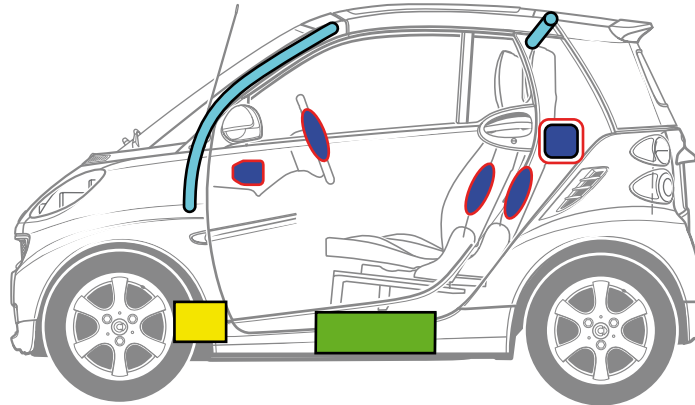
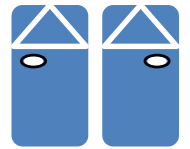

- 1 Veicolo con guida a sinistra
- 2 Veicolo con guida a destra



Airbag

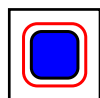

Pretensionatore



Centralina di comando sistemi di ritenuta



Rinforzo carrozzeria



Serbatoio carburante

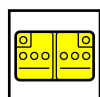

Batteria

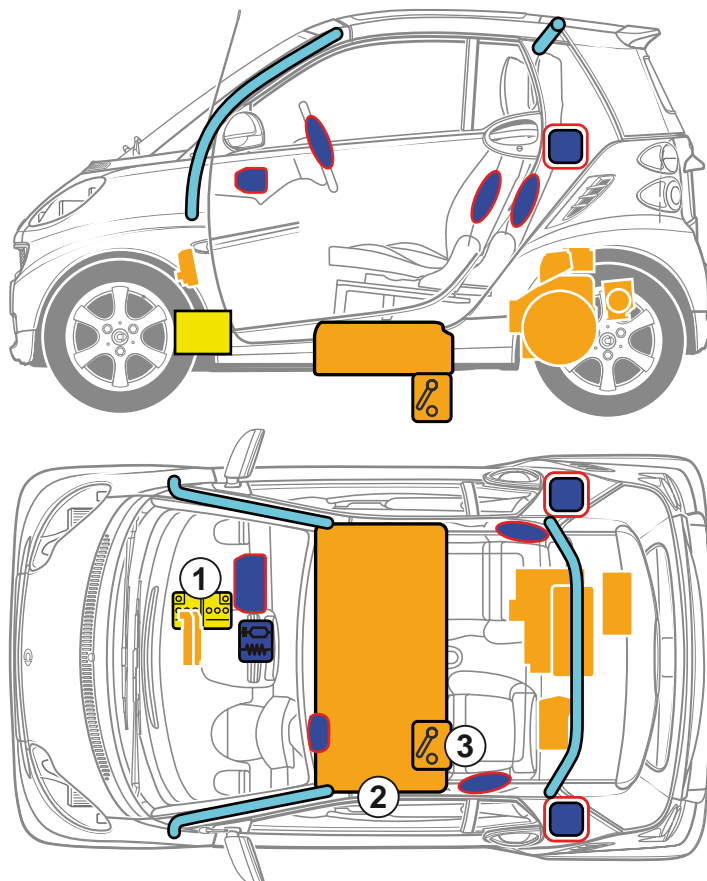
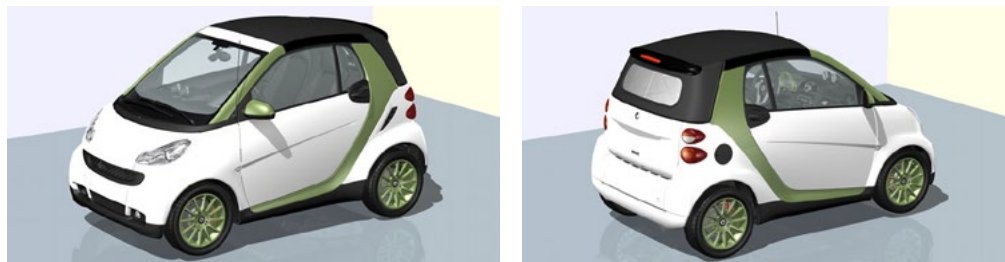

- 1 Batteria (12 V)
- 2 Batteria ad alto voltaggio
- 3 Dispositivo di disinserimento alto voltaggio



Airbag

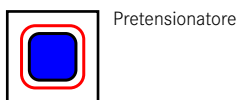

Pretensionatore

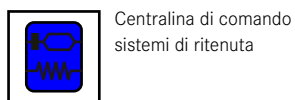

Centralina di comando sistemi di ritenuta

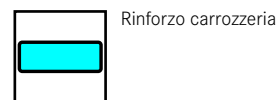

Rinforzo carrozzeria

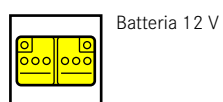

Batteria 12 V

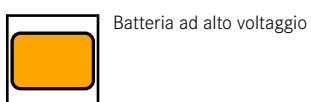

Batteria ad alto voltaggio



Componenti per l'alto voltaggio



Dispositivo di disinserimento alto voltaggio



Identificazione veicolo

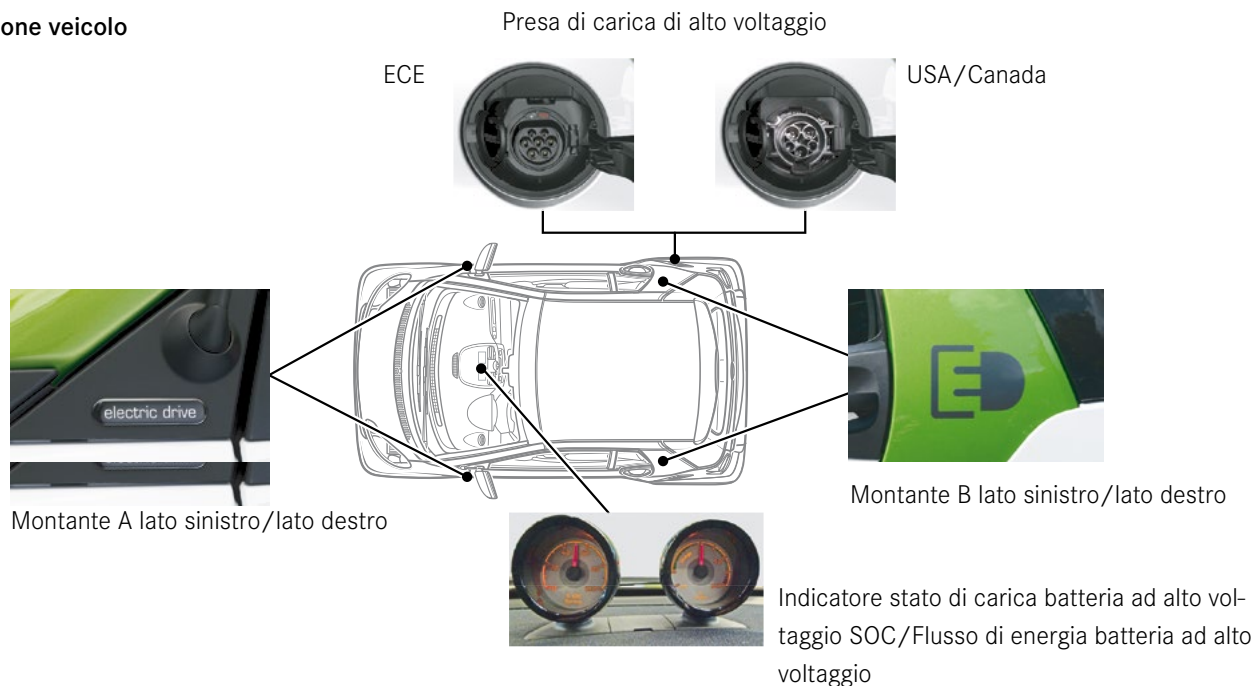

Dispositivo di disinserimento alto voltaggio

Il dispositivo di disinserimento alto voltaggio si trova sul lato inferiore della batteria ad alto voltaggio in direzione di marcia nella parte posteriore sinistra.

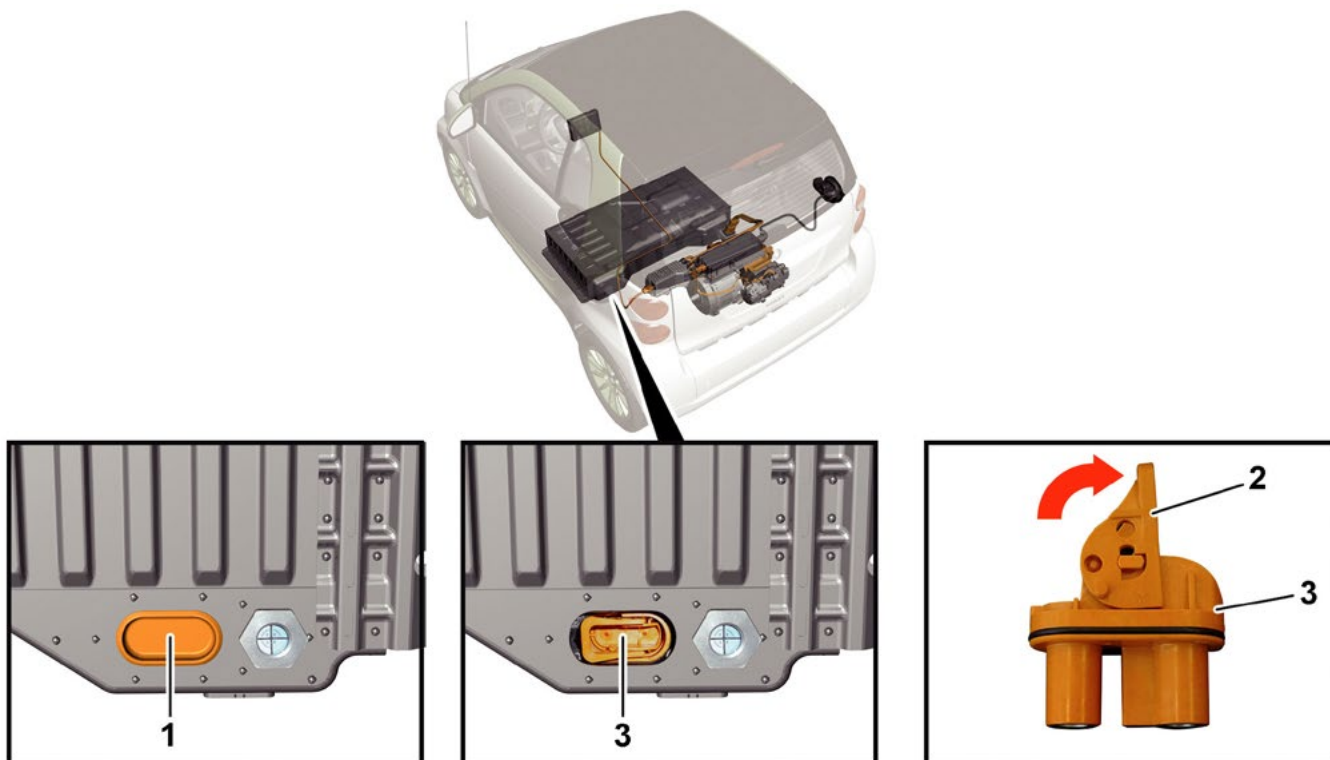

Rimuovere la copertura (1) / Aprire il bloccaggio (2) sul connettore a spina (3) / Estrarre il connettore a spina (3) dalla batteria ad alto voltaggio

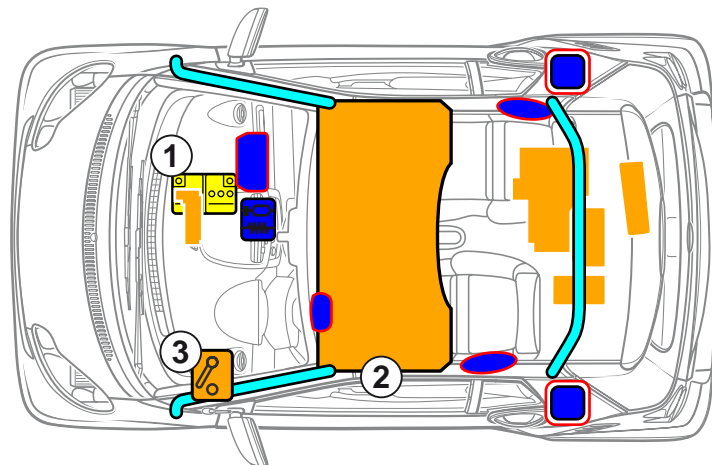
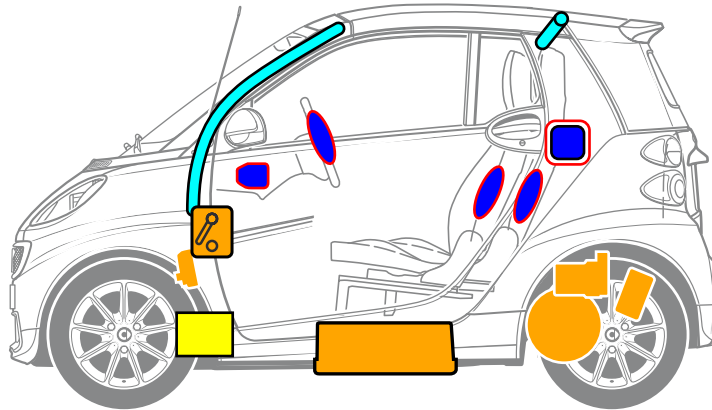

- 1 Batteria (12 V)
- 2 Batteria ad alto voltaggio
- 3 Dispositivo di disinserimento alto voltaggio



Airbag

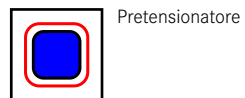

Pretensionatore

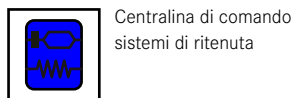

Centralina di comando sistemi di ritenuta



Rinforzo carrozzeria

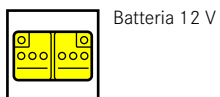

Batteria 12 V

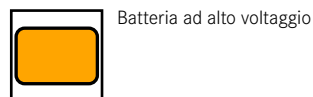

Batteria ad alto voltaggio

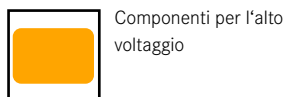

Componenti per l'alto voltaggio

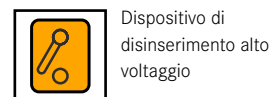

Dispositivo di disinserimento alto voltaggio



Identificazione veicolo

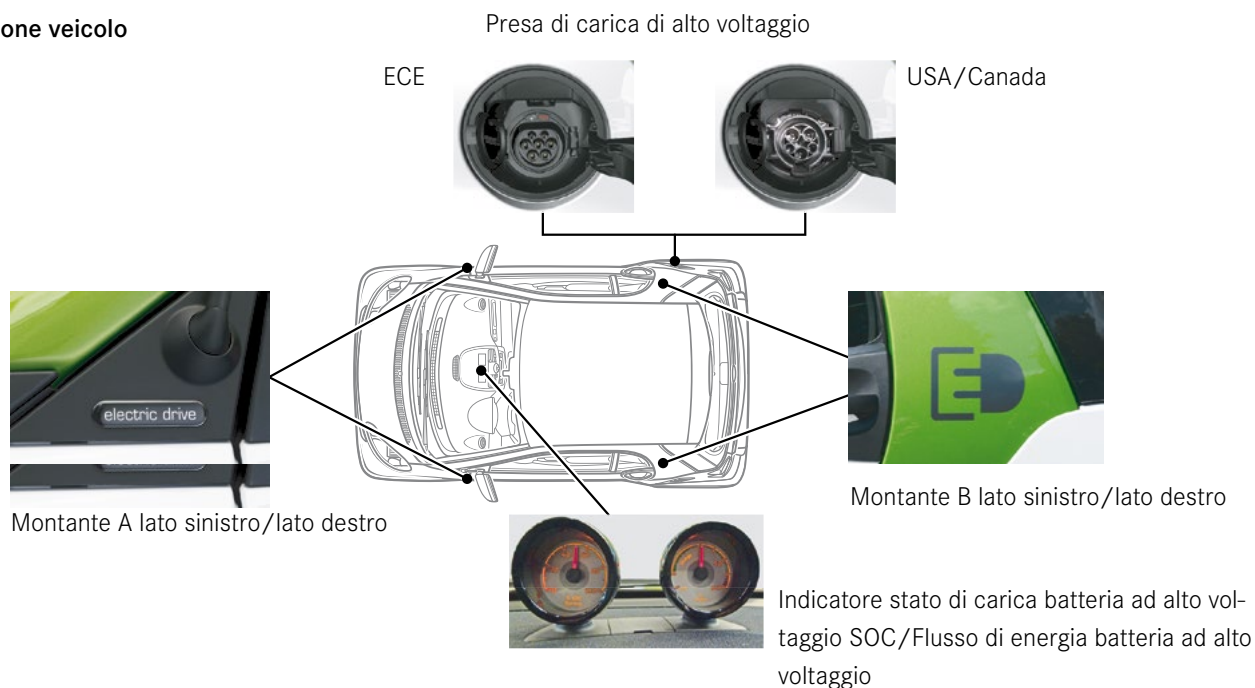

Dispositivo di disinserimento alto voltaggio

Il dispositivo di disinserimento alto voltaggio si trova sul lato inferiore della plancia portastrumenti in direzione di marcia a sinistra.



Estrarre il connettore a spina (1) dal supporto

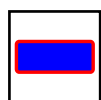
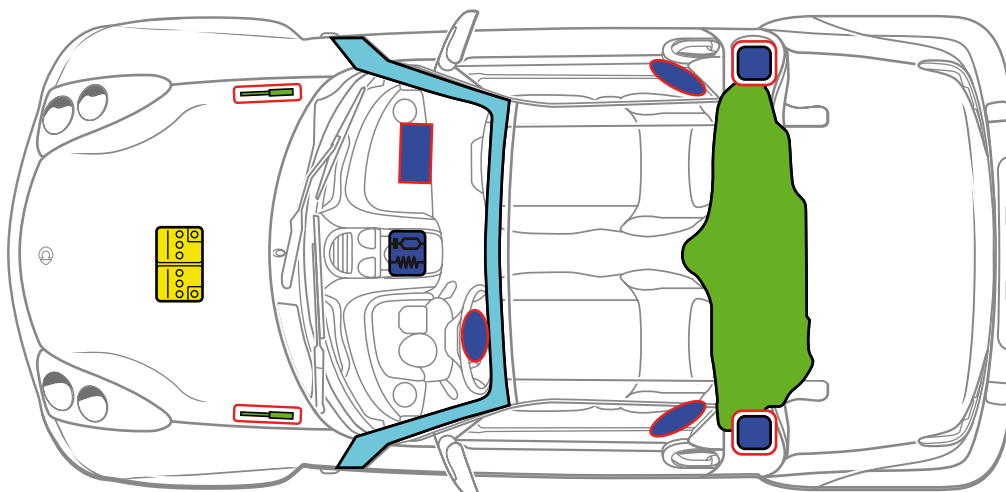
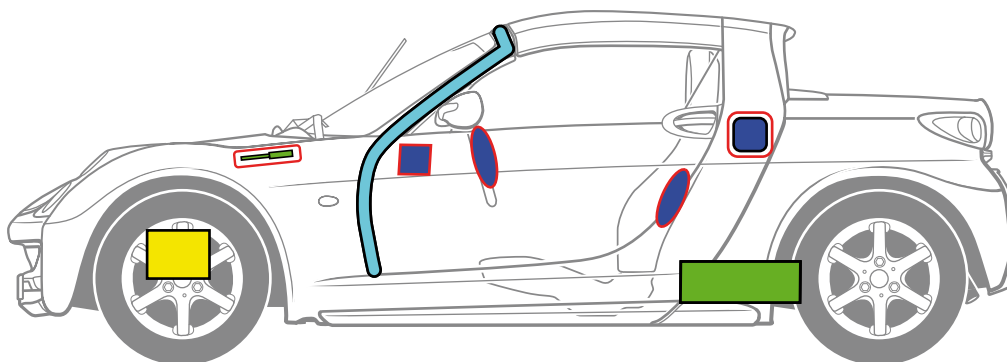

Airbag

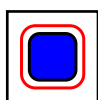

Pretensionatore

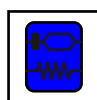

Centralina di comando
 sistemi di ritenuta



Ammortizzatore
 pneumatico

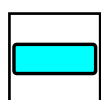

Rinforzo carrozzeria

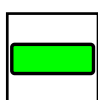

Serbatoio carburante

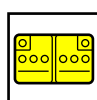

Batteria

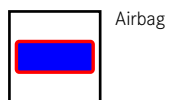
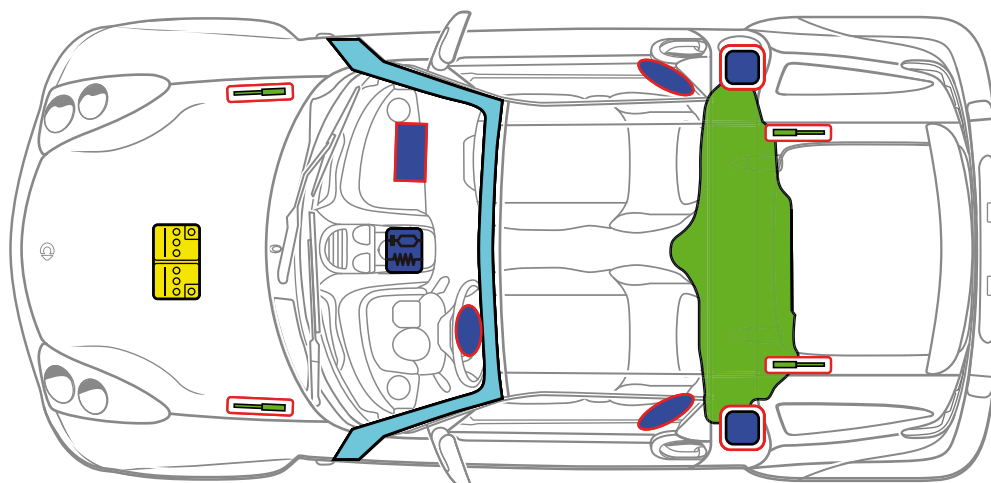
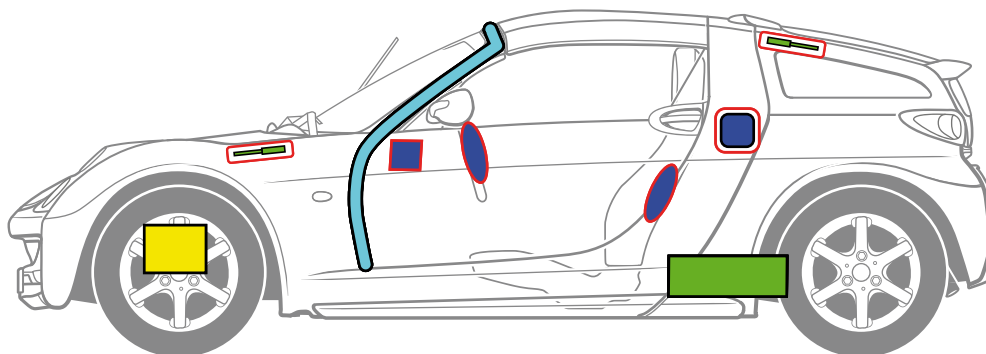

Airbag

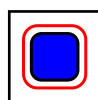

Pretensionatore

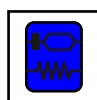

Centralina di comando sistemi di ritenuta



Ammortizzatore pneumatico

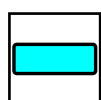

Rinforzo carrozzeria

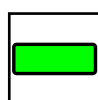

Serbatoio carburante

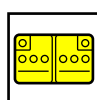

Batteria

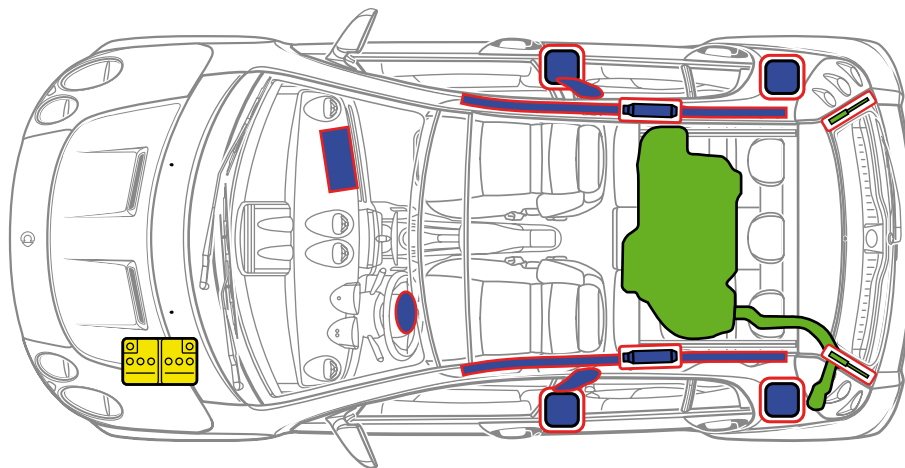
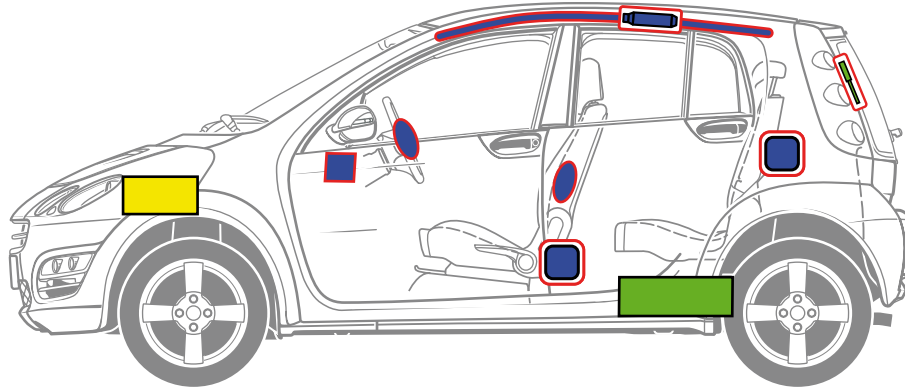

Airbag

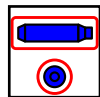

Generatore di gas



Pretensionatore



Centralina di comando sistemi di ritenuta



Ammortizzatore pneumatico

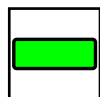

Serbatoio carburante



Batteria

