



# Rettungsdatenblätter

## 3

- 350Z Coupé Z33 2002-2009
- 350Z Cabriolet Z33 2003-2009
- 370Z Coupé Z34 2009-
- 370Z Cabriolet Z34 2009-

## A

- ALMERA 3-Türer N16 1995-2007
- ALMERA 4-Türer N16 1995-2007
- ALMERA 5-Türer N16 1995-2007
- ALMERA TINO V10 2000-2006

## C

- CABSTAR F24 2006-
- CUBE Z12 2010-

## E

- EVALIA M20M 2011-

## G

- GT-R R35 2008-

## I

- INTERSTAR X70 2004-

## J

- JUKE F15 2010-

## L

- LEAF ZE0 2011-2013
- LEAF ZE0 2013-

## M

- MICRA 3-Türer K11 1996-2003
- MICRA 5-Türer K11 1996-2003
- MICRA 3-Türer K12 2003-2010
- MICRA 5-Türer K12 2003-2010
- MICRA C+C K12 2005-2009
- MICRA 5-Türer K13 2010-
- MURANO Z50 2005-2008
- MURANO Z51 2008-

## N

- NAVARA King Cab D40 2005-
- NAVARA Crew Cab D40 2005-
- NOTE E11 2006-2013
- NOTE E12 2013-
- NP300 Single Cab D22 2008-
- NP300 King Cab D22 2008-
- NP300 Crew Cab D22 2008-
- NV200 M20 2009-
- NV400 M9 2011-

## P

- PATHFINDER R51 2005-
- PATROL 3-Türer Y61 2000-
- PATROL 5-Türer Y61 2000-
- PIXO UA0 2009-
- PRIMASTAR X83 2003-
- PRIMERA 4-Türer P11 1994-2002
- PRIMERA 5-Türer P11 1994-2002
- PRIMERA Kombi P11 1994-2002
- PRIMERA 4-Türer P12 2002-2008
- PRIMERA 5-Türer P12 2002-2008
- PRIMERA Kombi P12 2002-2008

## Q

- QASHQAI J10 2007-2014
- QASHQAI+2 J10 2008-2014
- QASHQAI J11 2014-

## T

- TIIDA C11 2006-

## X

- X-TRAIL T30 2001-2007
- X-TRAIL T31 2007-







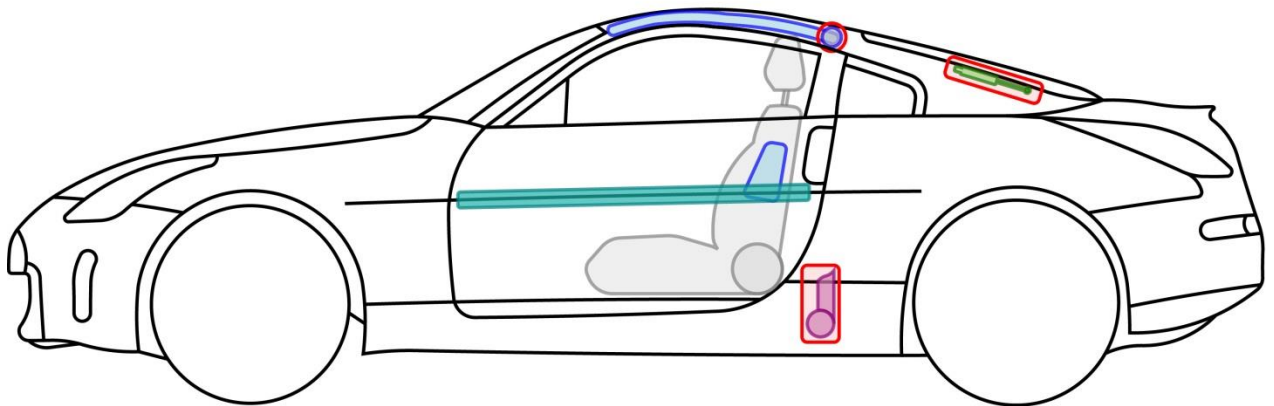
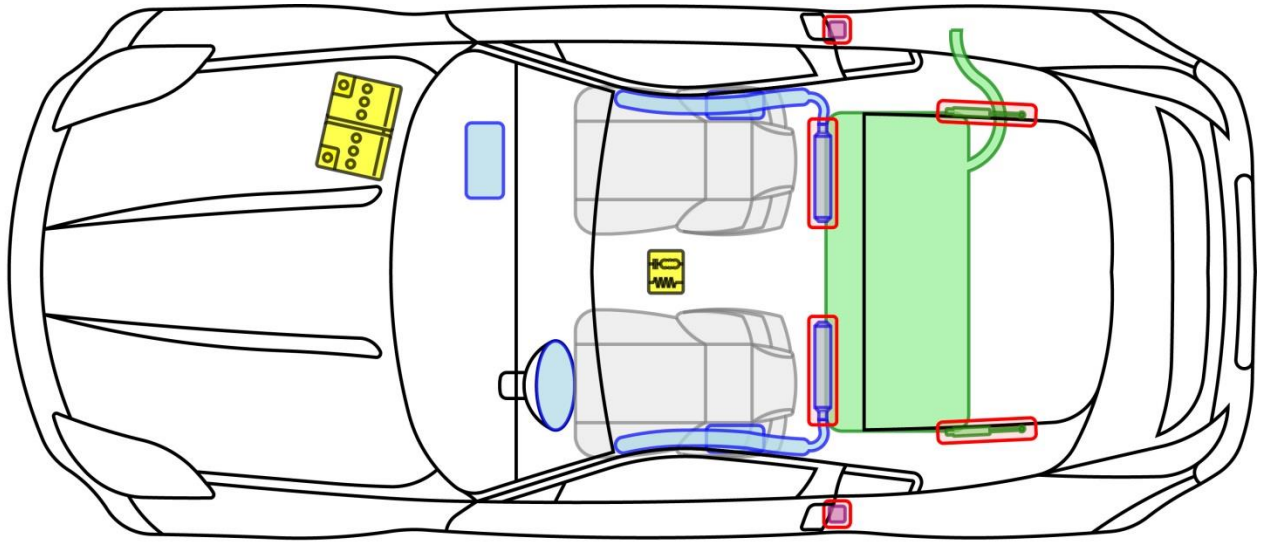

# 350Z Coupé

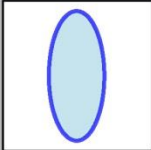
Typ: Z33, 2002-2009

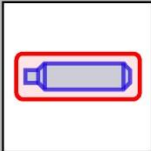

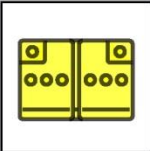
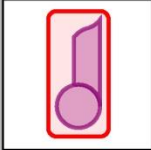
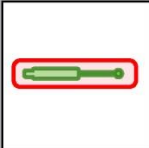
## Legende

	Airbag		Karosserie- verstärkung		Steuergerät
	Gas- generator		Überroll- schutz		Batterie
	Gurt- straffer		Gasdruck- dämpfer		Kraftstoff- tank

350Z







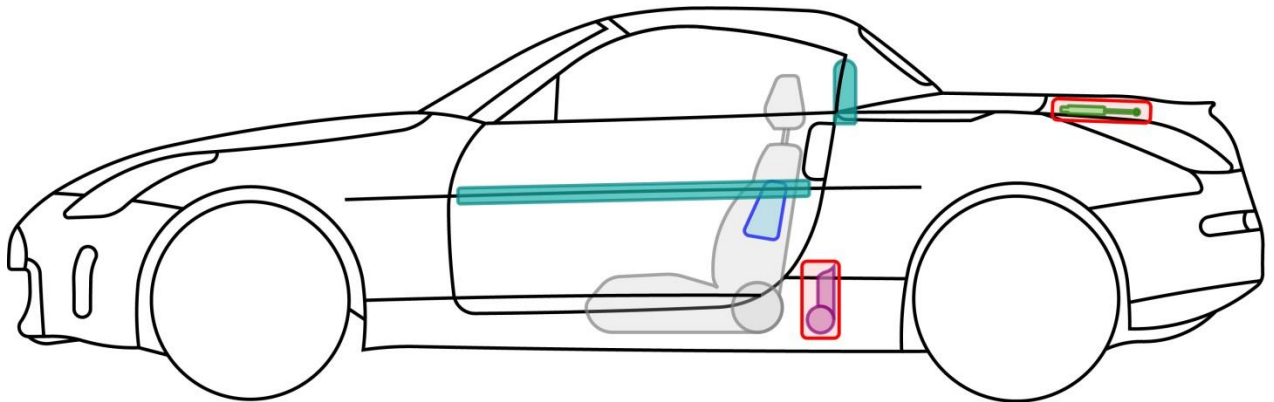
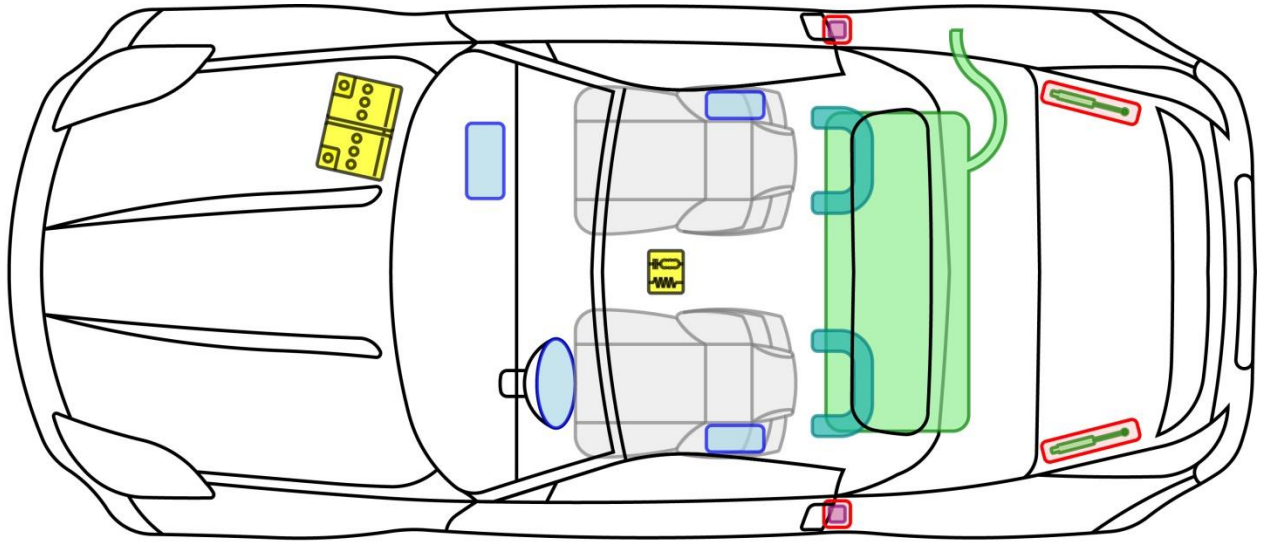

# 350Z Cabriolet

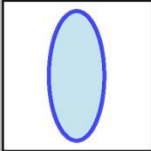
Typ: Z33, 2003-2009

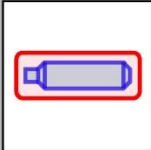

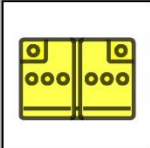
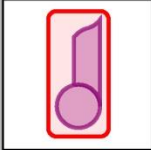
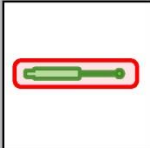
## Legende

	Airbag		Karosserie- verstärkung		Steuergerät
	Gas- generator		Überroll- schutz		Batterie
	Gurt- straffer		Gasdruck- dämpfer		Kraftstoff- tank

350Z







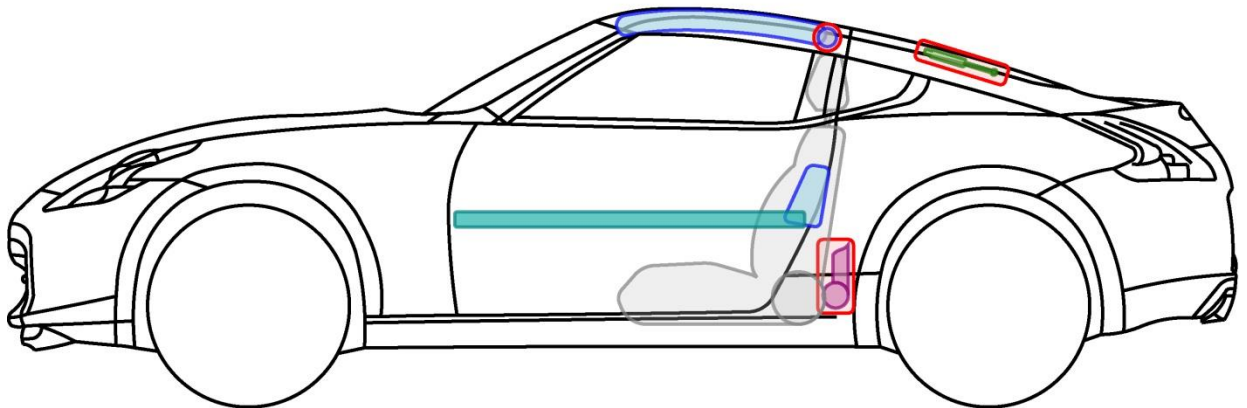
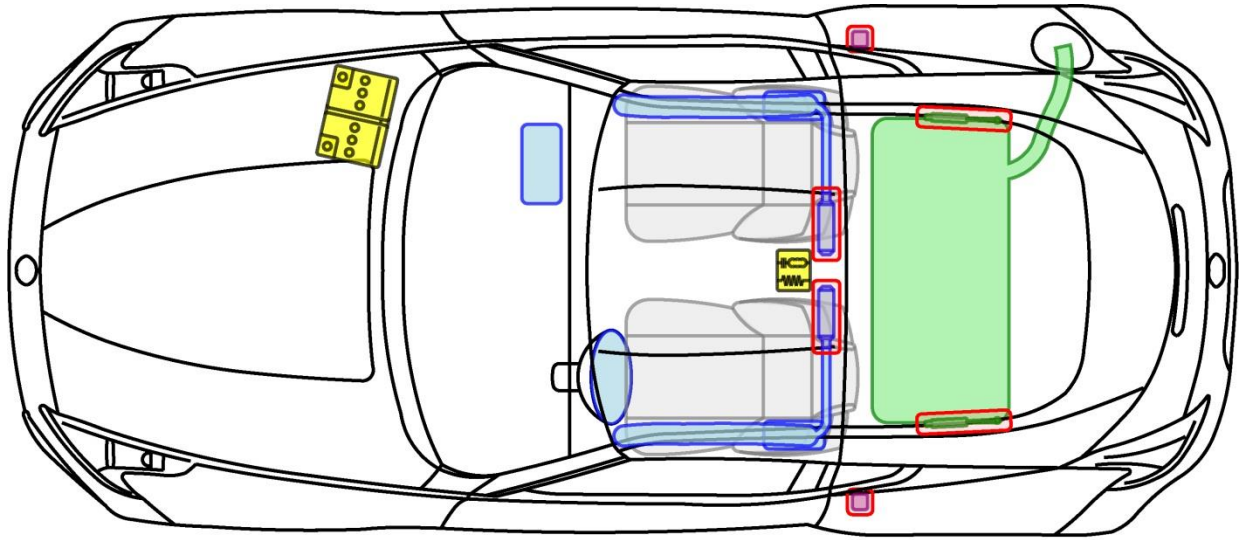

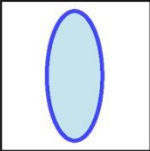

# 370Z Coupé

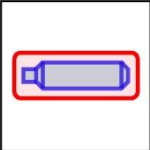
Typ: Z34, 2009-

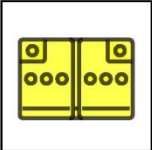

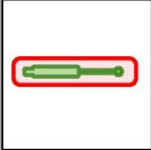
## Legende

	Airbag		Karosserie- verstärkung		Steuergerät
	Gas- generator		Überroll- schutz		Batterie
	Gurt- straffer		Gasdruck- dämpfer		Kraftstoff- tank

370Z







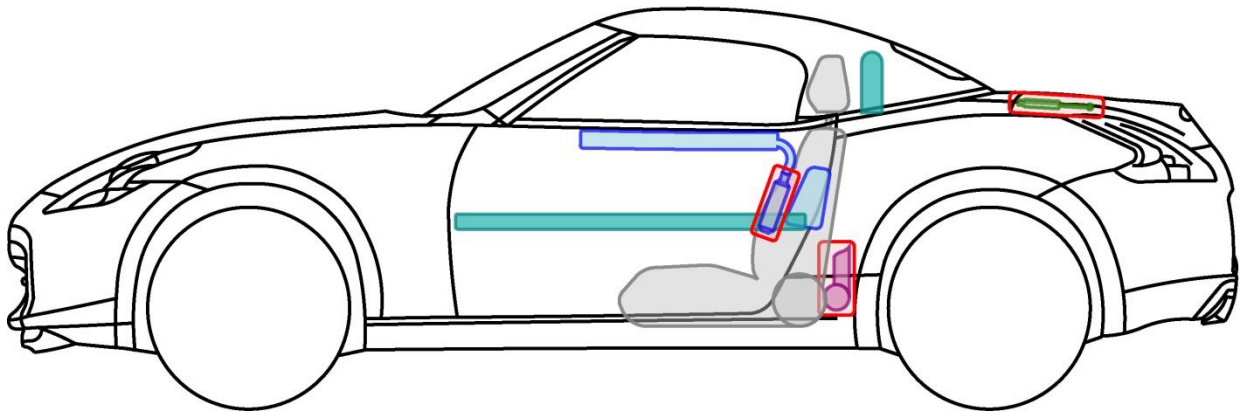
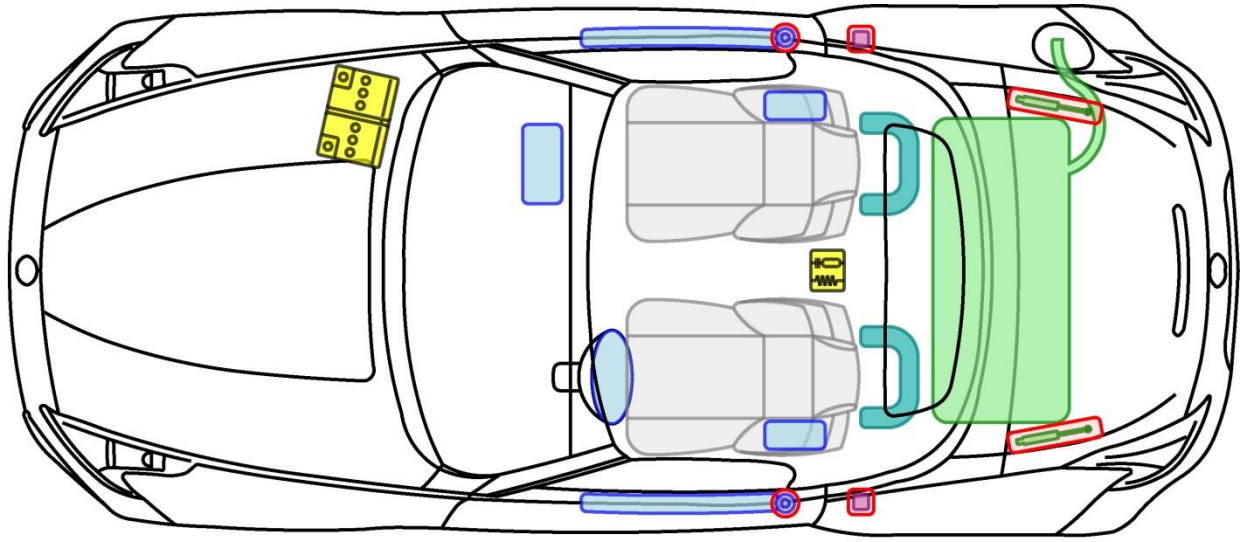

# 370Z Cabriolet

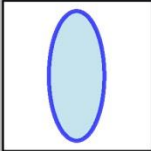
Typ: Z34, 2010-

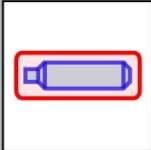

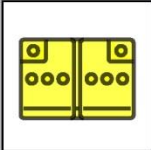
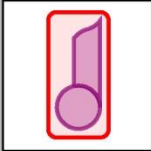
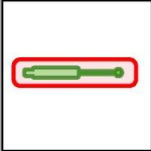
## Legende

	Airbag		Karosserie- verstärkung		Steuergerät
	Gas- generator		Überroll- schutz		Batterie
	Gurt- straffer		Gasdruck- dämpfer		Kraftstoff- tank

370Z







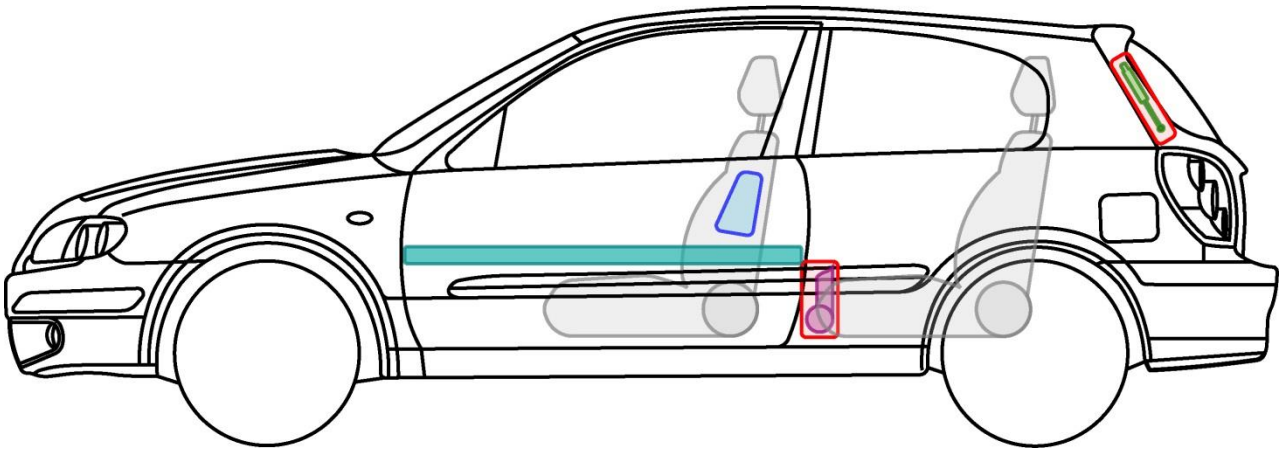
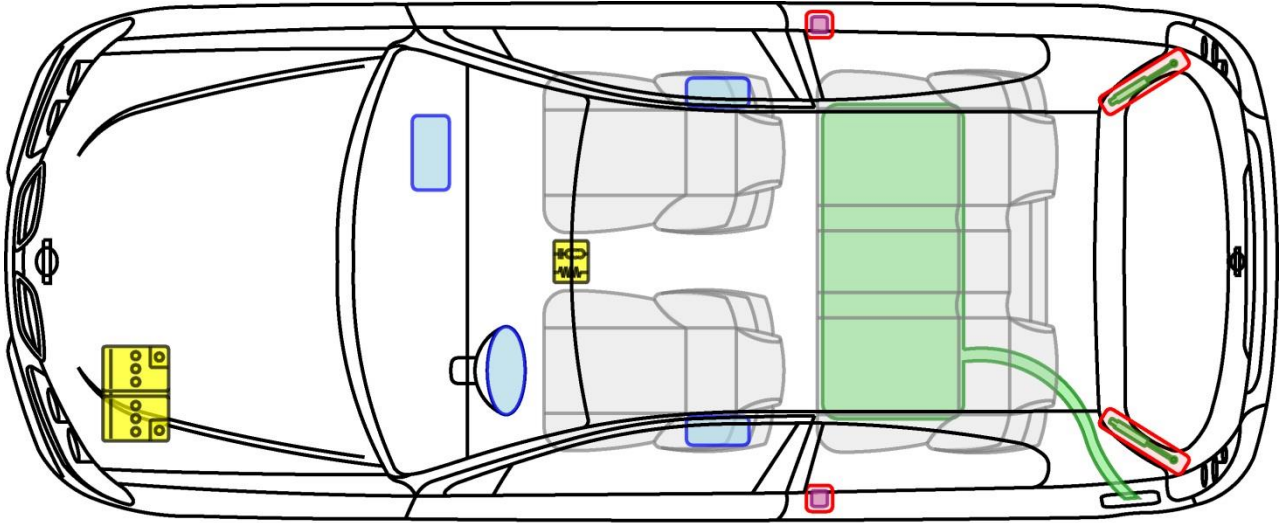

# ALMERA 3-Türer

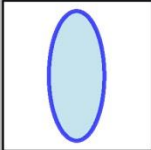
Typ: N16, 1995-2007

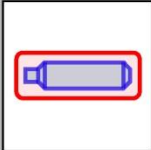

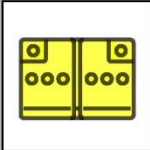
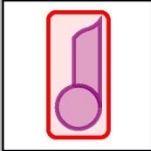
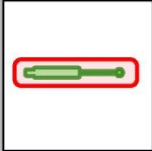
## Legende

	Airbag		Karosserie- verstärkung		Steuergerät
	Gas- generator		Überroll- schutz		Batterie
	Gurt- straffer		Gasdruck- dämpfer		Kraftstoff- tank

ALMERA



# ALMERA 4-Türer

Typ: N16, 1995-2007

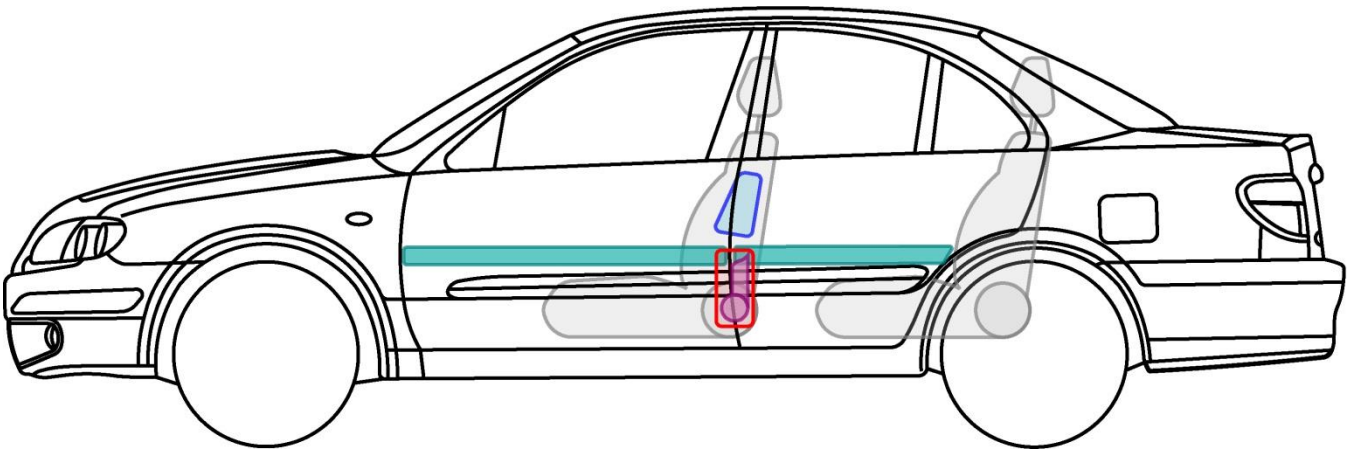
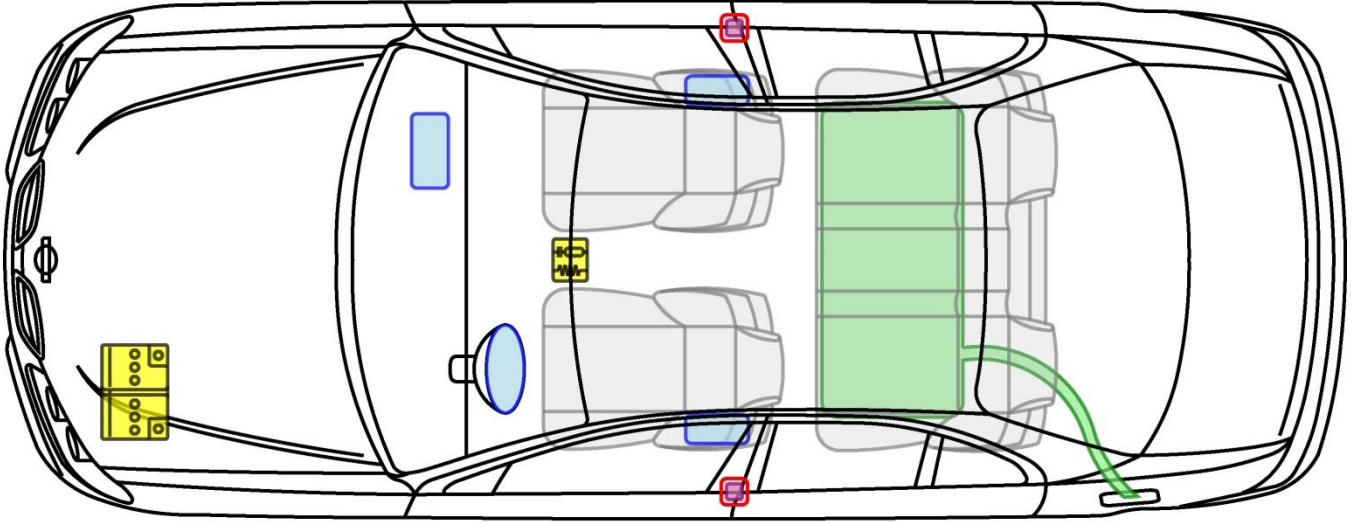

## Legende

	Airbag		Karosserie- verstärkung		Steuergerät
	Gas- generator		Überroll- schutz		Batterie
	Gurt- straffer		Gasdruck- dämpfer		Kraftstoff- tank

ALMERA







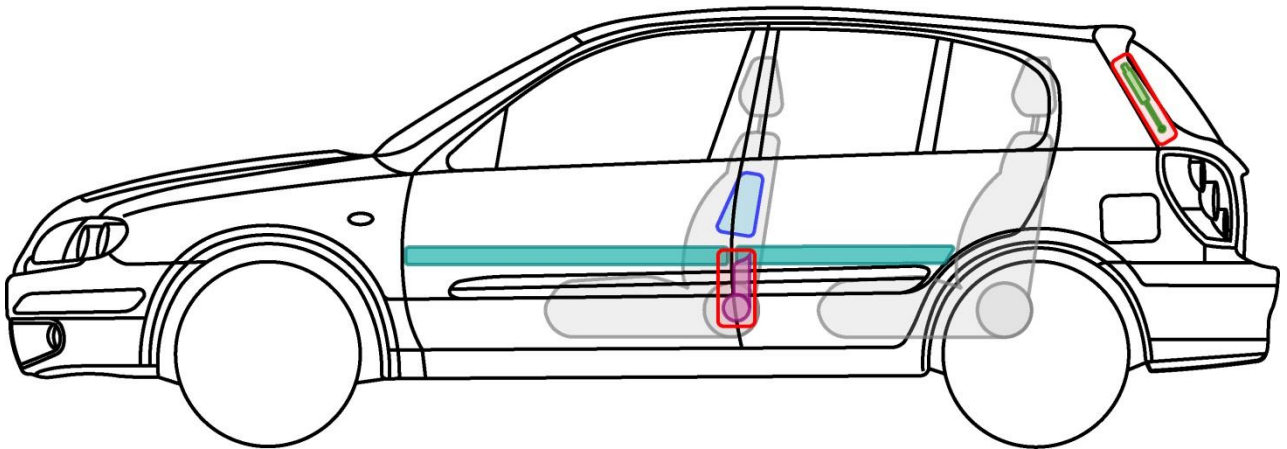
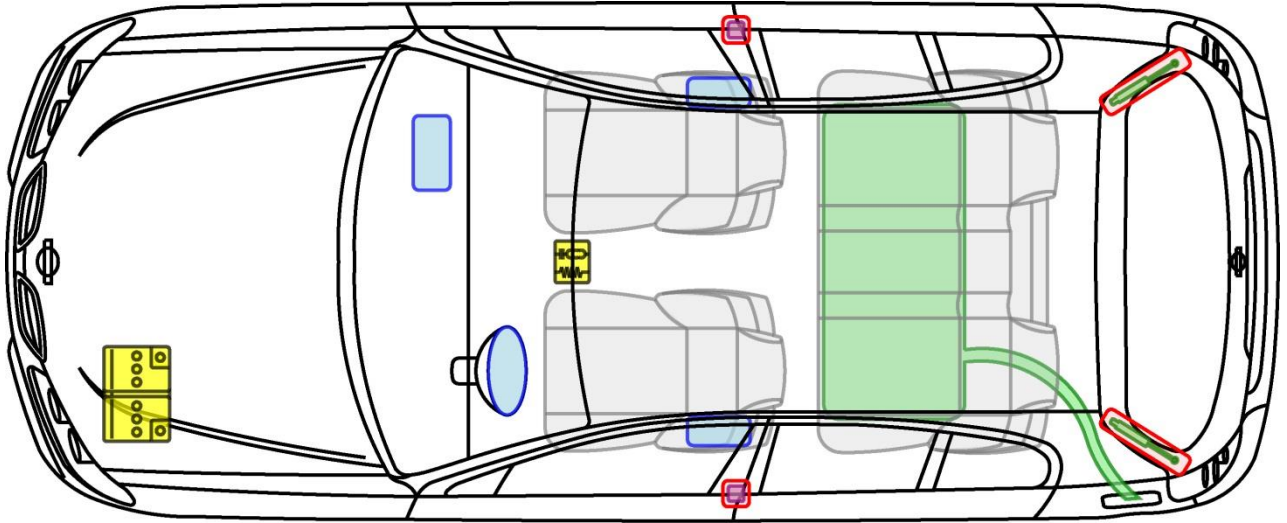

# ALMERA 5-Türer

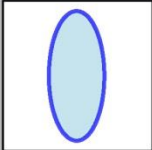
Typ: N16, 1995-2007

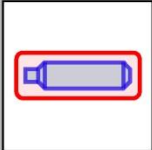

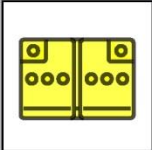
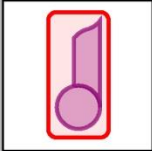
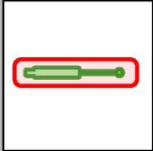
## Legende

	Airbag		Karosserie- verstärkung		Steuergerät
	Gas- generator		Überroll- schutz		Batterie
	Gurt- straffer		Gasdruck- dämpfer		Kraftstoff- tank

ALMERA





# ALMERA TINO

Typ: V10, 2000-2006

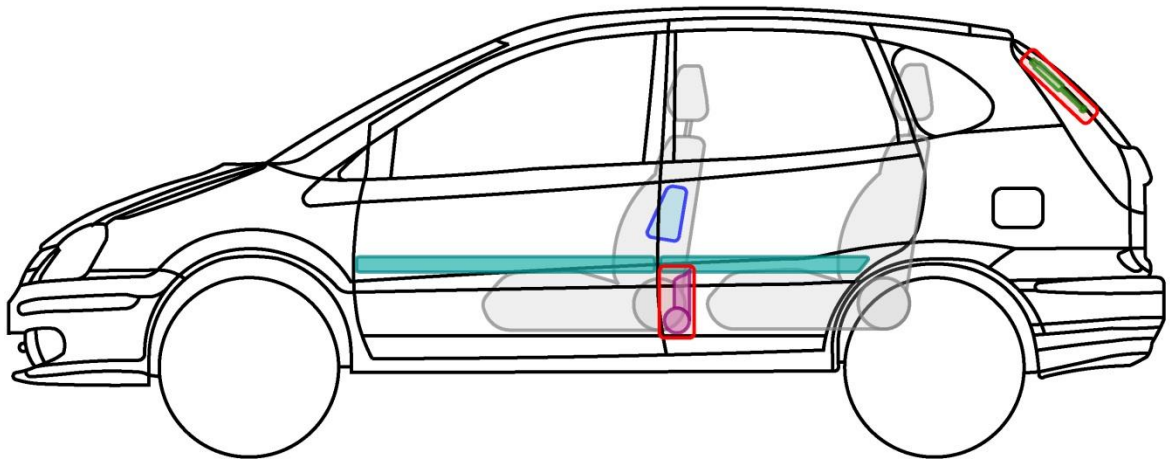
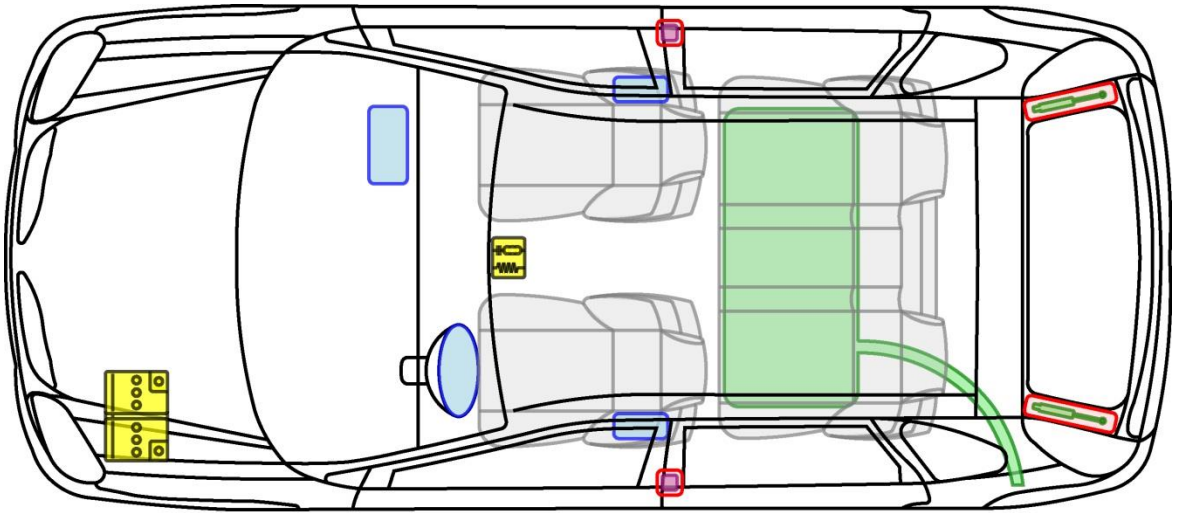

## Legende

	Airbag		Karosserie- verstärkung		Steuergerät
	Gas- generator		Überroll- schutz		Batterie
	Gurt- straffer		Gasdruck- dämpfer		Kraftstoff- tank

ALMERA TINO



# CABSTAR

Typ: F24, 2006-

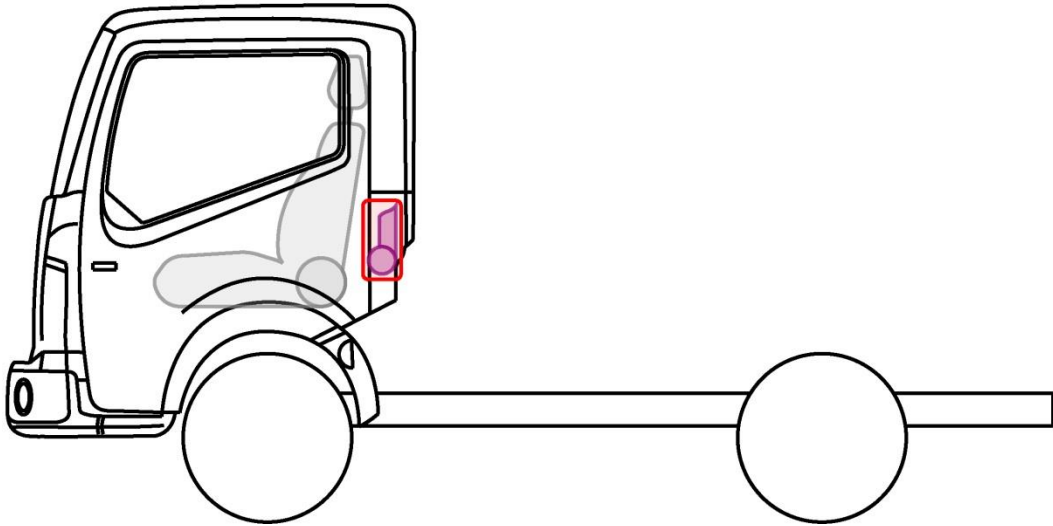
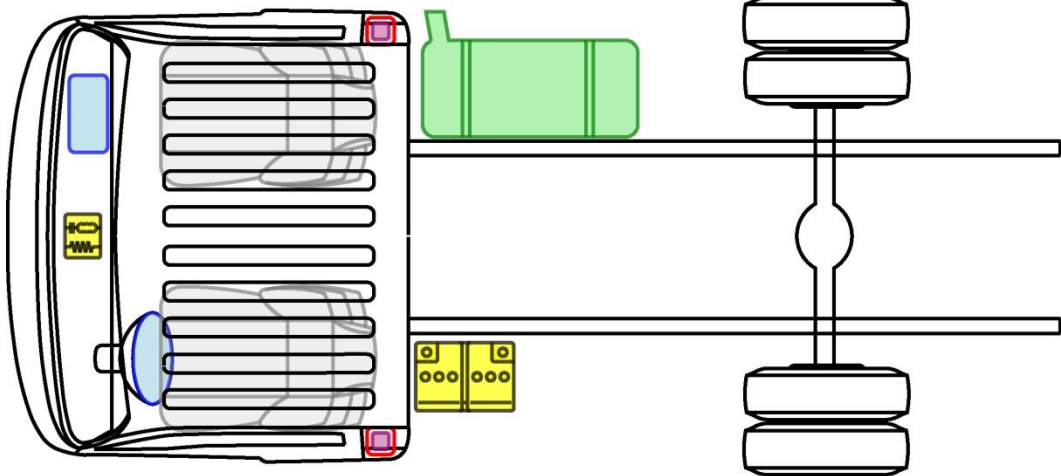

## Legende

	Airbag		Karosserie- verstärkung		Steuergerät
	Gas- generator		Überroll- schutz		Batterie
	Gurt- straffer		Gasdruck- dämpfer		Kraftstoff- tank

CABSTAR



# CUBE

Typ: Z12, 2010-

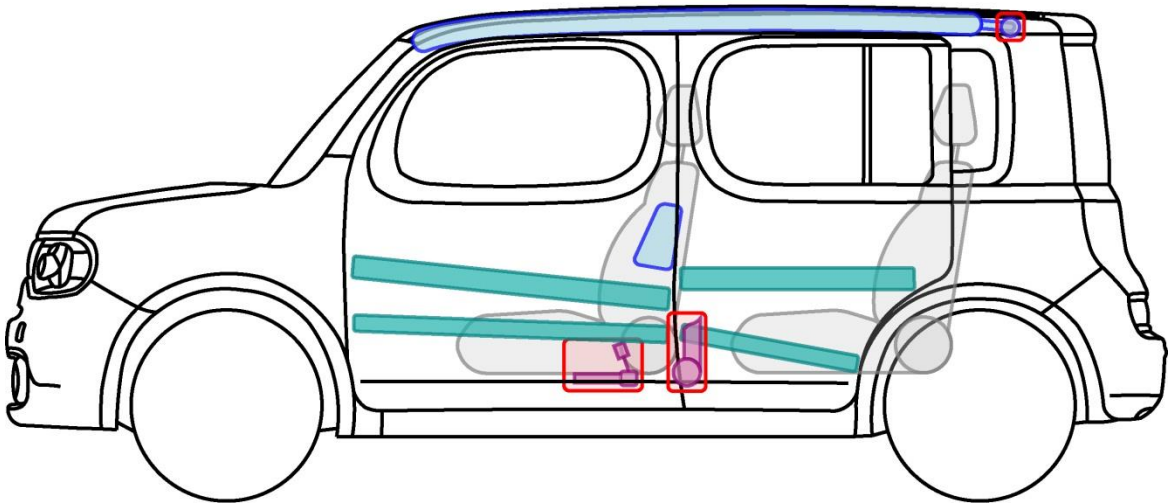
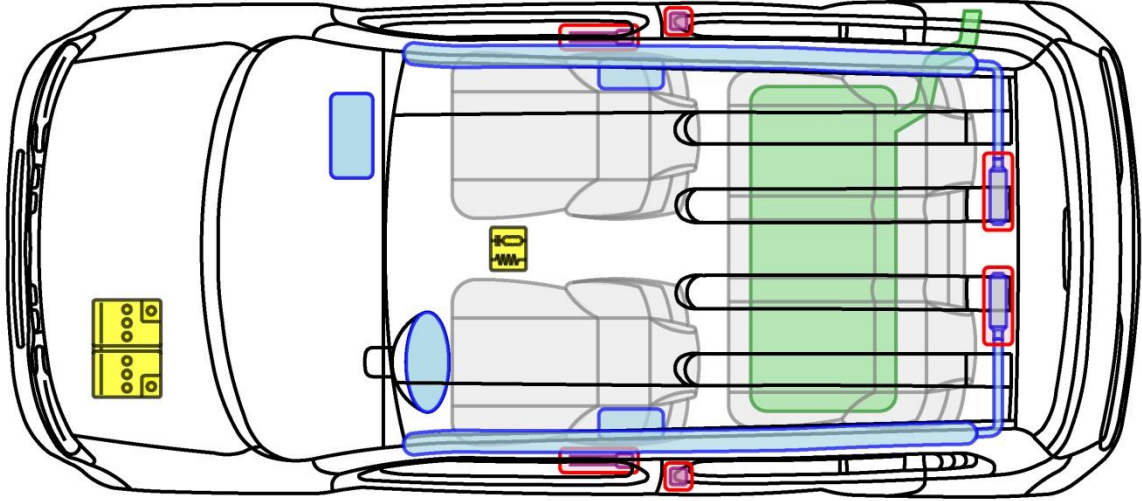

## Legende

	Airbag		Karosserie- verstärkung		Steuergerät
	Gas- generator		Überroll- schutz		Batterie
	Gurt- straffer		Gasdruck- dämpfer		Kraftstoff- tank









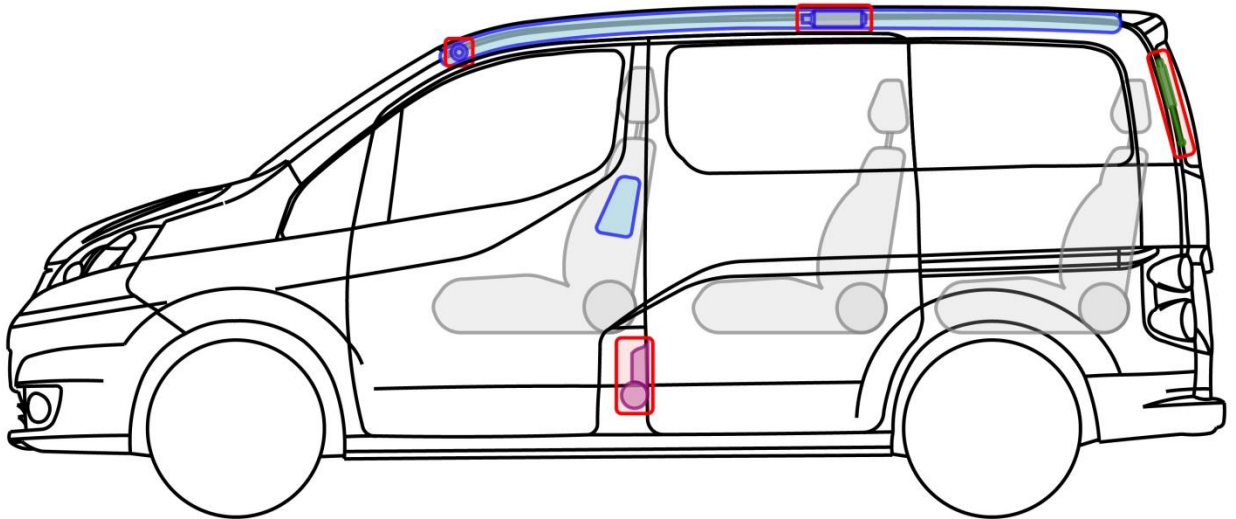
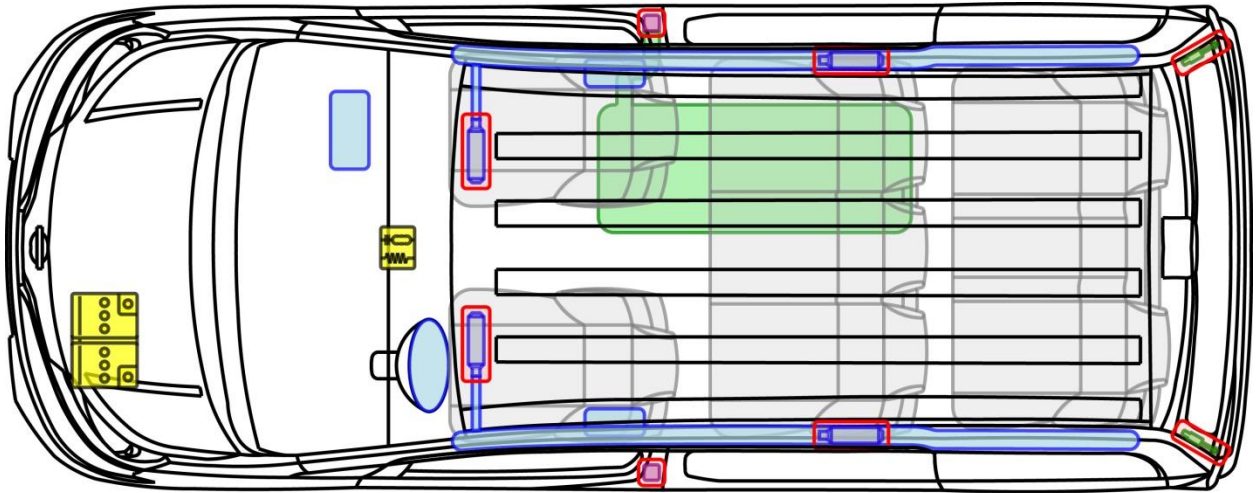

# EVALIA

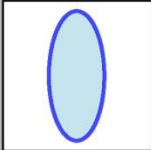
Typ: M20M, 2011-

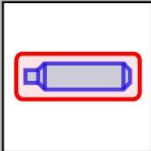

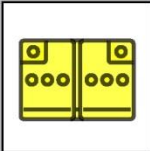
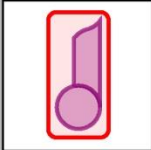
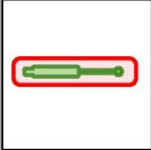
## Legende

	Airbag		Karosserie- verstärkung		Steuergerät
	Gas- generator		Überroll- schutz		Batterie
	Gurt- straffer		Gasdruck- dämpfer		Kraftstoff- tank







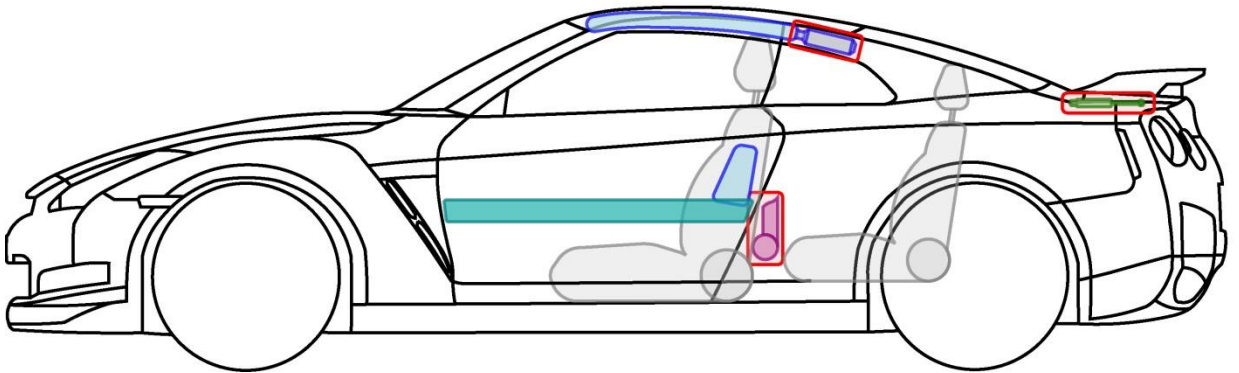
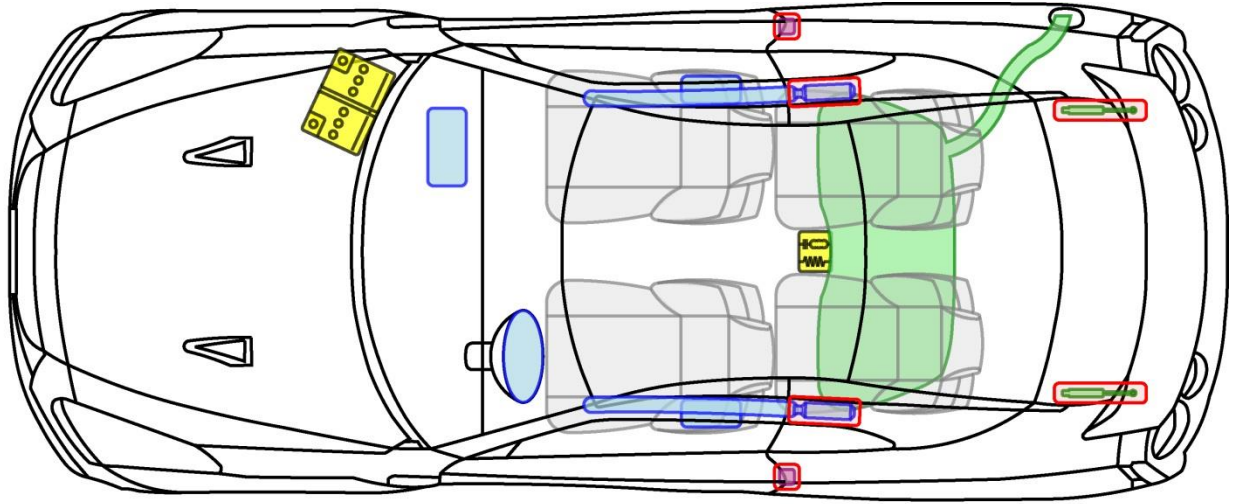

# GT-R

Typ: R35, 2008-

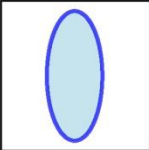

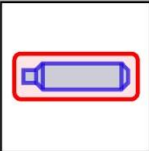
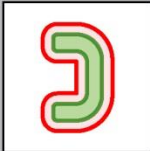
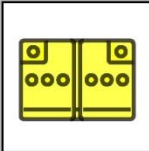
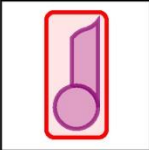
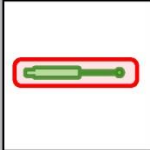
### Legende

	Airbag		Karosserie- verstärkung		Steuergerät
	Gas- generator		Überroll- schutz		Batterie
	Gurt- straffer		Gasdruck- dämpfer		Kraftstoff- tank

GT-R



# INTERSTAR

Typ: X70, 2004-

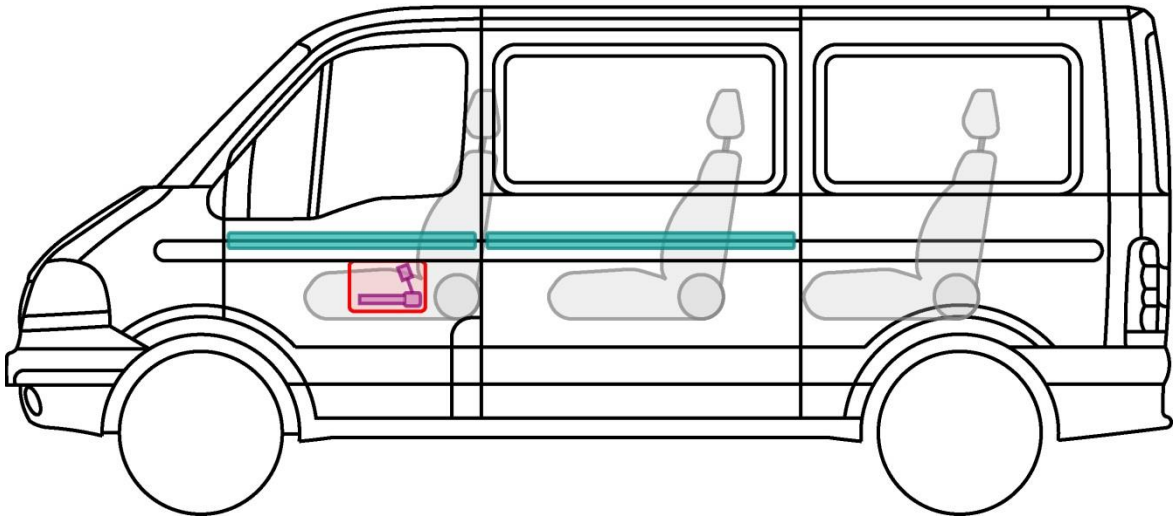
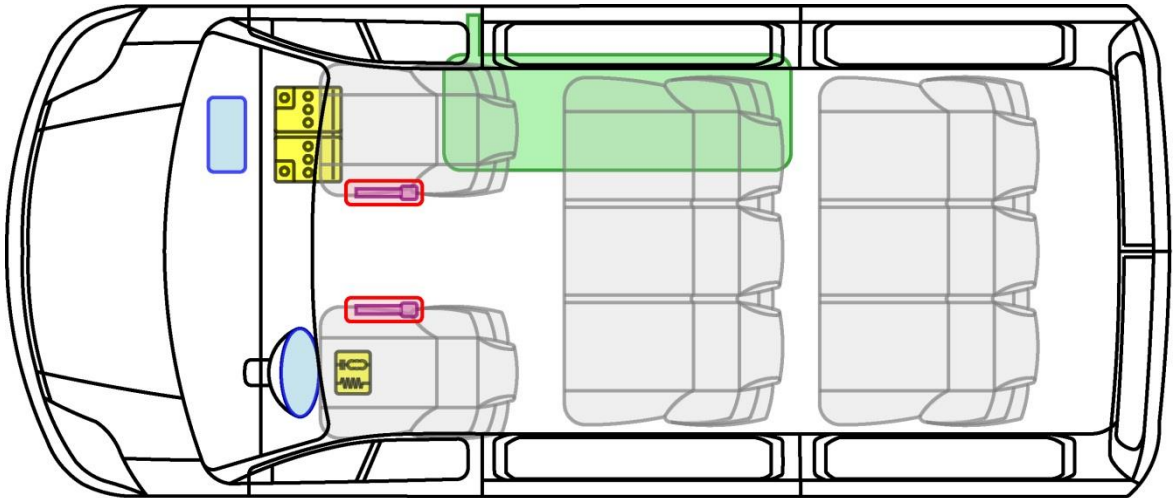

## Legende

	Airbag		Karosserie- verstärkung		Steuergerät
	Gas- generator		Überroll- schutz		Batterie
	Gurt- straffer		Gasdruck- dämpfer		Kraftstoff- tank





# JUKE

Typ: F15, 2010-

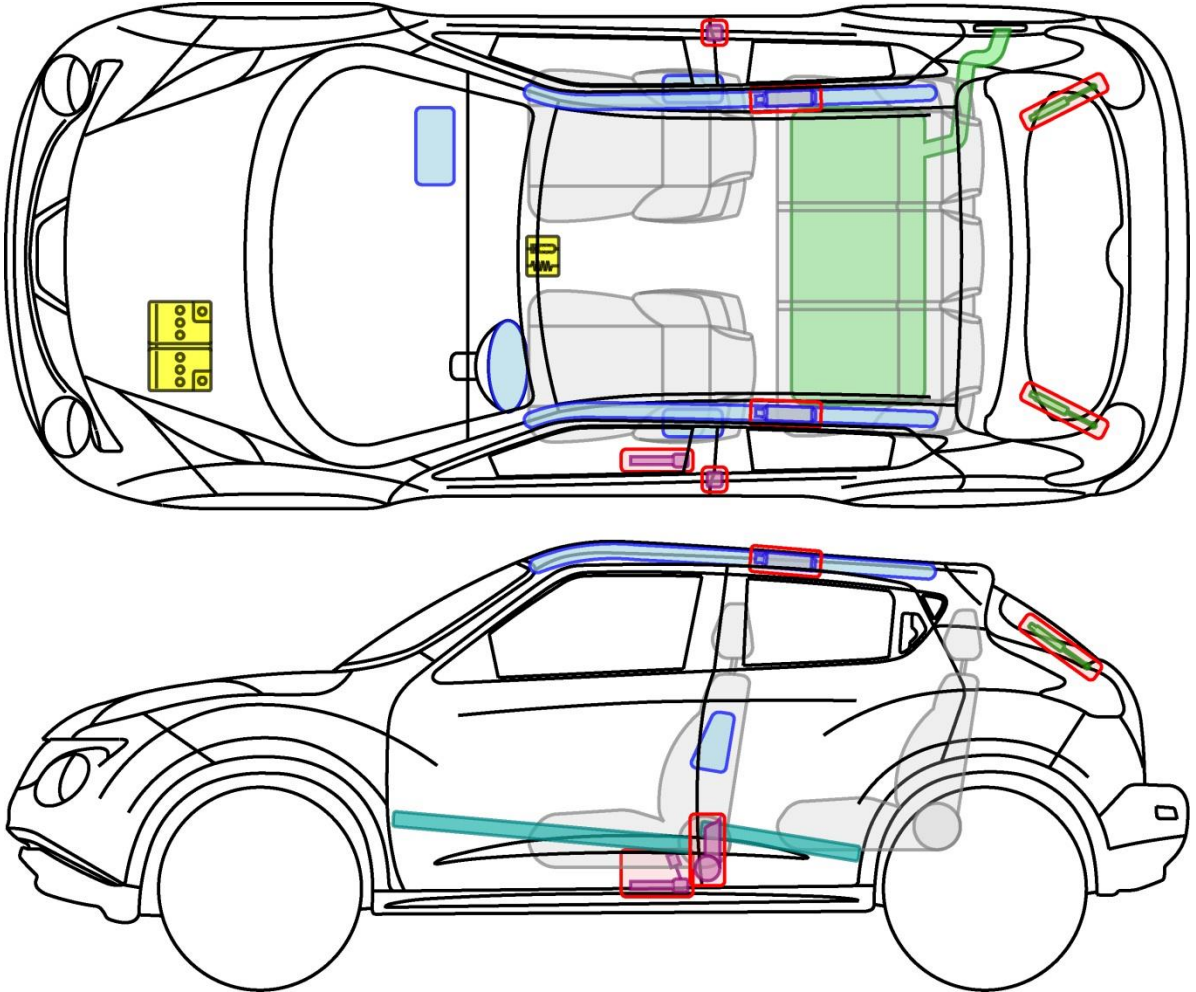

## Legende

	Airbag		Karosserie- verstärkung		Steuergerät
	Gas- generator		Überroll- schutz		Batterie
	Gurt- straffer		Gasdruck- dämpfer		Kraftstoff- tank





# LEAF

Typ: ZE0, 2011-2013  
JN1FAAZE0Uxxxxxxx

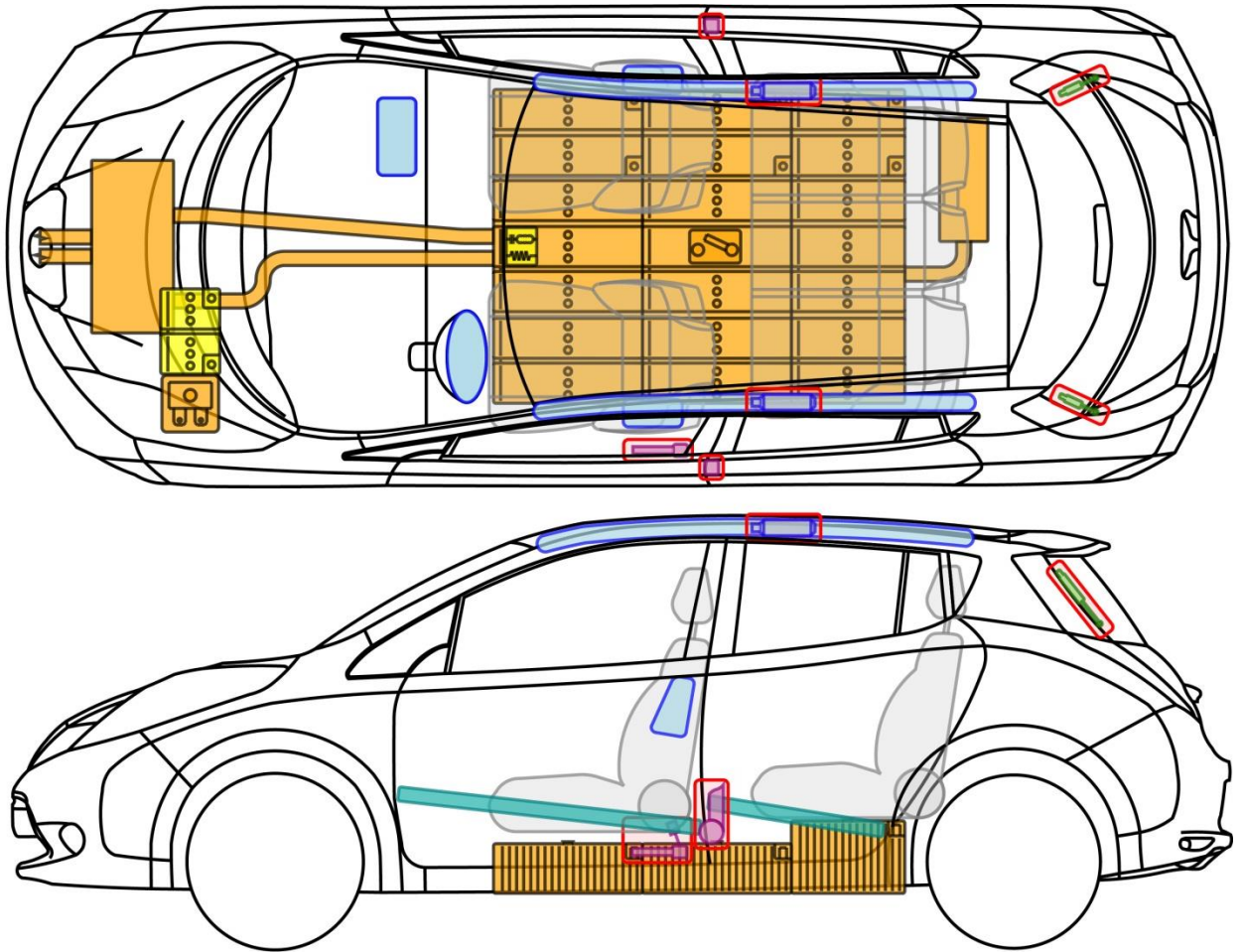

## Legende

	Airbag		Karosserie-verstärkung		Steuergerät		Hochvolt-leitung/-komponente
	Gas-generator		Überroll-schutz		12 V Batterie		HV-Trennstelle
	Gurt-straffer		Gasdruck-dämpfer		Hochvolt-batterie		Sicherungs-kasten
	Kraftstoff-tank						







# LEAF

Typ: ZE0, 2011-2013

JN1FAAZE0Uxxxxxxx



## Allgemeine Hinweise

- Bei Unfällen mit Airbag und/oder Gurtstrafferauslösung wird der Fahrzeugantrieb automatisch deaktiviert. Die Rückhaltesysteme sind weiterhin aktiv.
- Die Zeit bis zur vollständigen Deaktivierung des Antriebs beträgt **10 Minuten** nach Durchführung der Deaktivierungsschritte.
- **Vor Beginn von Arbeiten am Fahrzeug Ladestecker ziehen!**
- **Schutzausrüstung erforderlich (Isolierende Handschuhe bis 1000 V, Gesichtsschutz).**

## Fahrzeug gegen wegrollen sichern

- Räder unterkeilen.
- Bremse betätigen
- Schalter der elektrische Parkbremse nach oben ziehen.



## Deaktivieren von Hochvolt- (HV) und Rückhaltesystem (SRS)

### Methode 1

1. Prüfen ob das Hochvoltsystem eingeschaltet ist. Symbol: 
2. Ist das System aktiv, Start-Stopp Knopf einmal betätigen.
3. 12 Volt Batterie abklemmen. Massekabel zuerst.





# LEAF

Typ: ZE0, 2011-2013  
JN1FAAZE0Uxxxxxxx



## Deaktivieren von Hochvolt- (HV) und Rückhaltesystem (SRS)

### Methode 2

1. Sicherungskasten lokalisieren und öffnen.



2. Dargestellte Sicherungen im Kastendeckel entfernen.

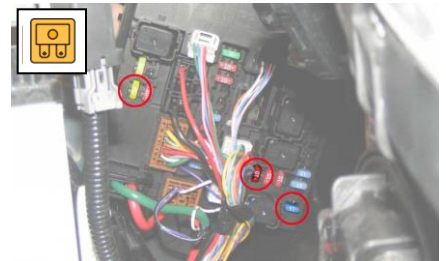

3. 12 Volt Batterie abklemmen. Massekabel zuerst.





# LEAF

Typ: ZE0, 2011-2013

JN1FAAZE0Uxxxxxxx



## Deaktivierung des Hochvoltsystem (HV)

### Methode 3

1. HV-Trennstelle lokalisieren.
2. Abdeckung öffnen, z.B. durch abschrauben (Schlüsselweite 10 mm) oder aufhebeln.
3. Servicestecker wie dargestellt entfernen!

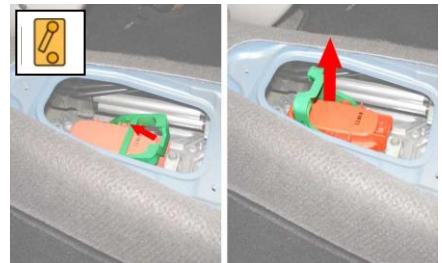
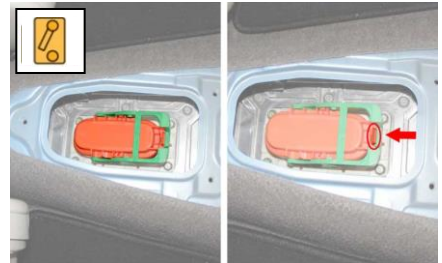

- **Kann die 12 Volt Batterie nicht abgeklemmt werden, sind die Rückhaltesysteme weiterhin aktiv!**



# LEAF

Typ: ZE0, 2013-  
SJNFAAZE0Uxxxxxxx

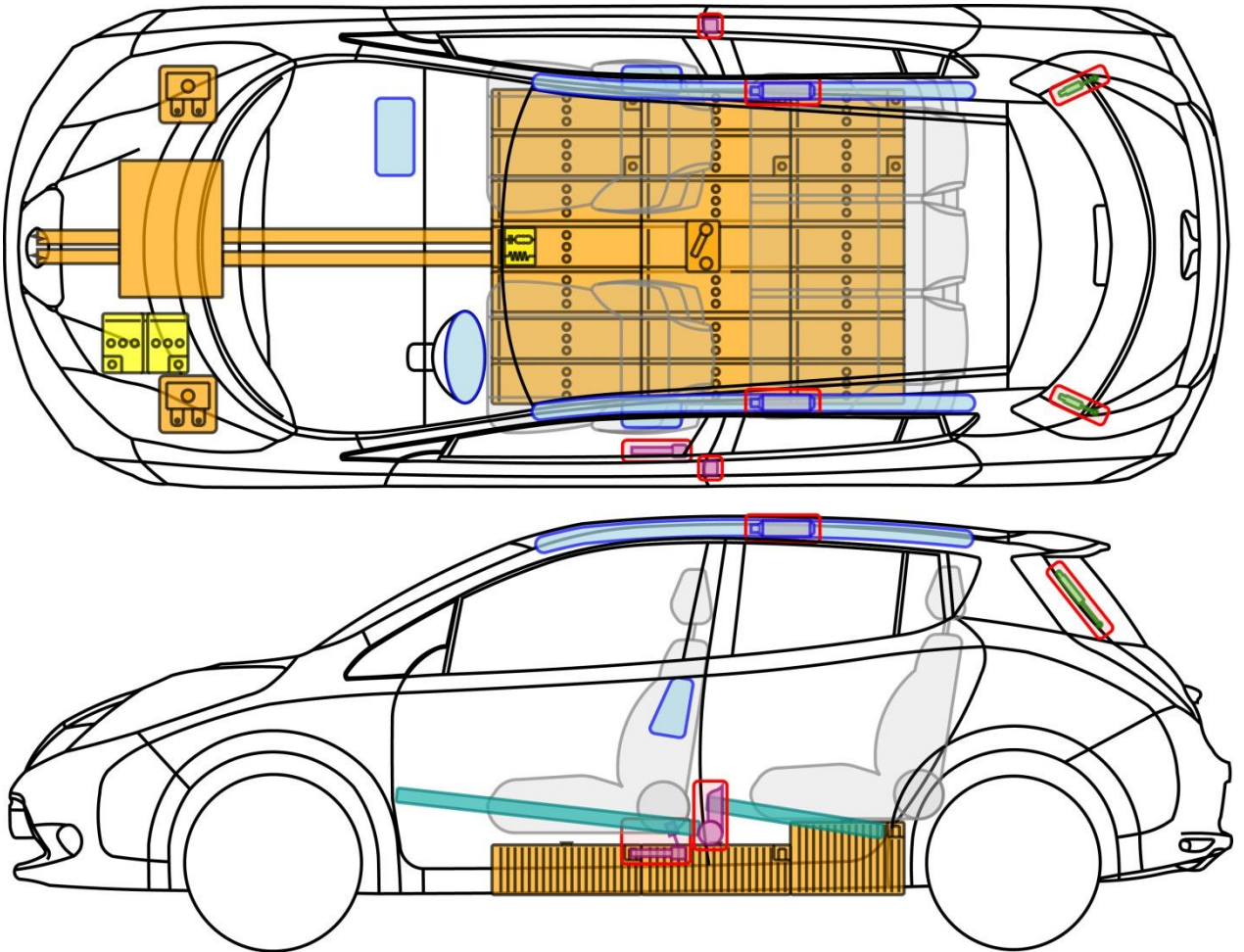

## Legende

	Airbag		Karosserie-verstärkung		Steuergerät		Hochvolt-leitung/-komponente
	Gas-generator		Überroll-schutz		12 V Batterie		HV-Trennstelle
	Gurt-straffer		Gasdruck-dämpfer		Hochvolt-batterie		Sicherungs-kasten
	Kraftstoff-tank						

LEAF



# LEAF

Typ: ZE0, 2013-  
SJNFAAZE0Uxxxxxxx



## Allgemeine Hinweise

- Bei Unfällen mit Airbag und/oder Gurtstrafferauslösung wird der Fahrzeugantrieb automatisch deaktiviert. Die Rückhaltesysteme sind weiterhin aktiv.
- Die Zeit bis zur vollständigen Deaktivierung des Antriebs beträgt **10 Minuten** nach Durchführung der Deaktivierungsschritte.
- **Vor Beginn von Arbeiten am Fahrzeug Ladestecker ziehen!**
- **Schutzausrüstung erforderlich (Isolierende Handschuhe bis 1000 V, Gesichtsschutz).**

## Fahrzeug gegen wegrollen sichern

- Räder unterkeilen.
- Fußfeststellbremse betätigen.

## Deaktivieren von Hochvolt- (HV) und Rückhaltesystem (SRS)

### Methode 1

1. Prüfen ob das Hochvoltsystem eingeschaltet ist. Symbol: 
2. Ist das System aktiv, Start-Stopp Knopf einmal betätigen.
3. 12 Volt Batterie abklemmen. Massekabel zuerst.





# LEAF

Typ: ZE0, 2013-

SJNFAAZE0Uxxxxxxx



## Deaktivieren von Hochvolt- (HV) und Rückhaltesystem (SRS)

### Methode 2

1. Sicherungskasten 1 lokalisieren und öffnen.



2. Dargestellte Sicherungen im Kastendeckel entfernen.



3. Sicherungskasten 2 lokalisieren und öffnen.



4. Dargestellte Sicherung im Kastendeckel entfernen.



5. 12 Volt Batterie abklemmen. Massekabel zuerst.





# LEAF

Typ: ZE0, 2013-

SJNFAAZE0Uxxxxxxx



## Deaktivierung des Hochvoltsystem (HV)

### Methode 3

1. HV-Trennstelle lokalisieren.
2. Abdeckung öffnen, z.B. durch abschrauben (Schlüsselweite 10 mm) oder aufhebeln.
3. Servicestecker wie dargestellt entfernen!



- **Kann die 12 Volt Batterie nicht abgeklemmt werden, sind die Rückhaltesysteme weiterhin aktiv!**







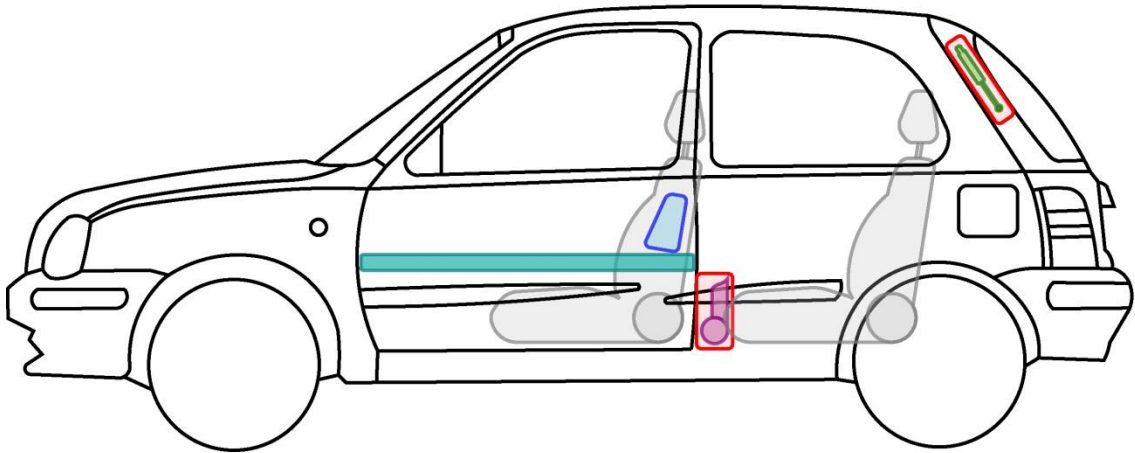
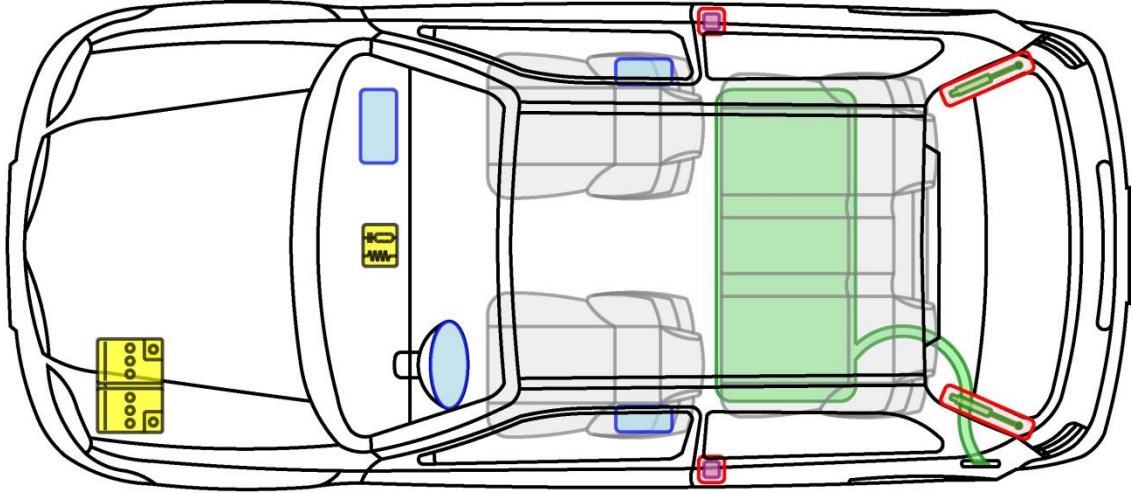

# MICRA 3-Türer

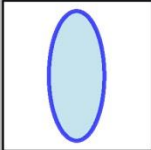
Typ: K11, 1996-2003

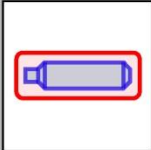

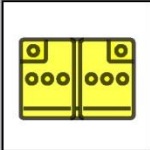
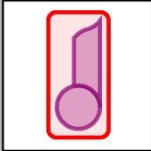
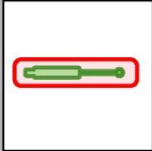
## Legende

	Airbag		Karosserie- verstärkung		Steuergerät
	Gas- generator		Überroll- schutz		Batterie
	Gurt- straffer		Gasdruck- dämpfer		Kraftstoff- tank

MICRA





# MICRA 5-Türer

Typ: K11, 1996-2003

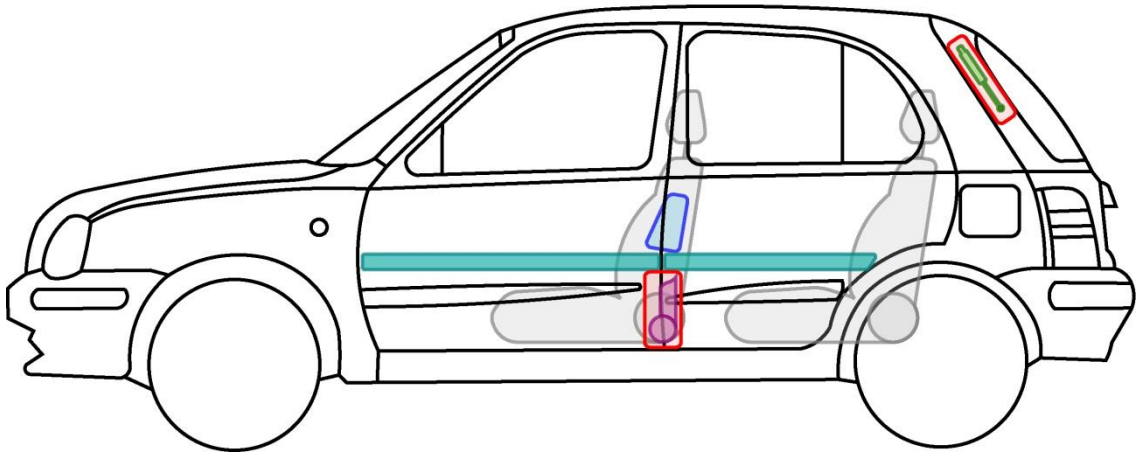
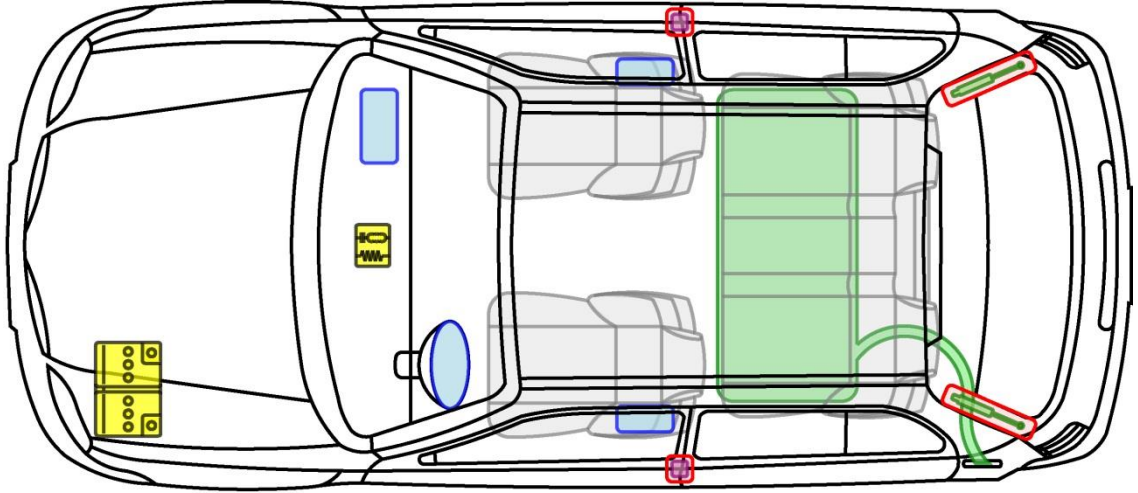

## Legende

	Airbag		Karosserie- verstärkung		Steuergerät
	Gas- generator		Überroll- schutz		Batterie
	Gurt- straffer		Gasdruck- dämpfer		Kraftstoff- tank

MICRA







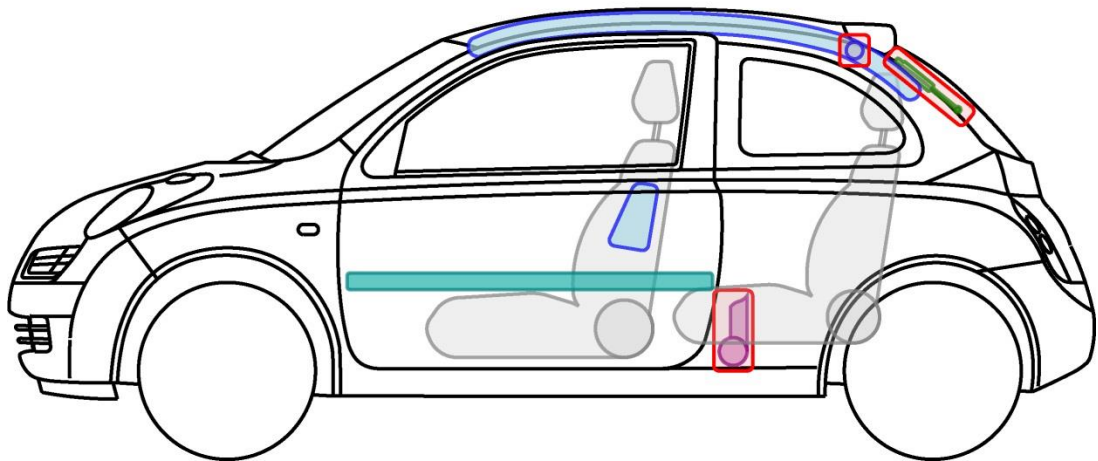
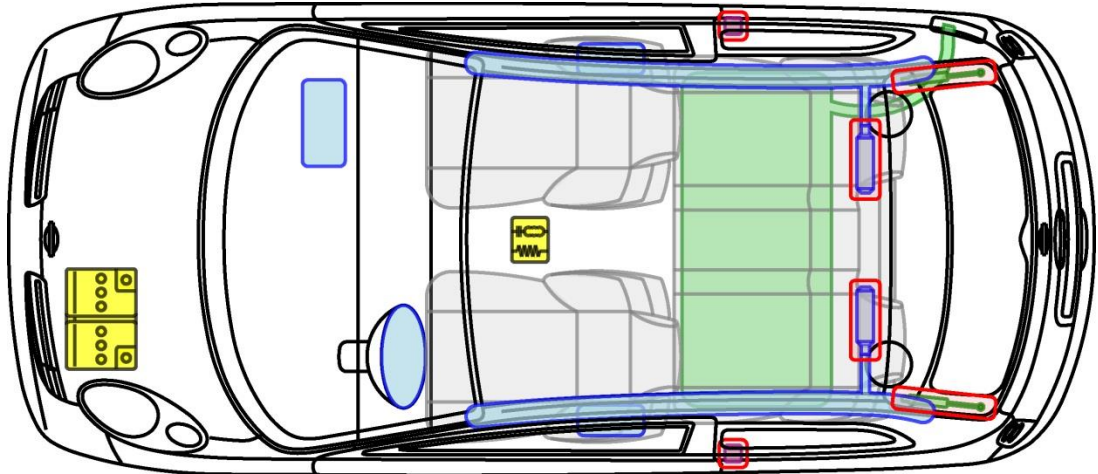

# MICRA 3-Türer

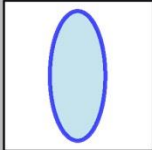
Typ: K12, 2003-2010

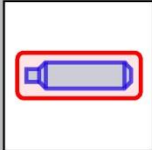
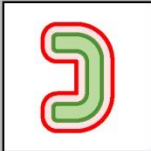
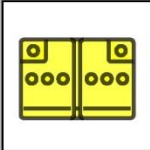

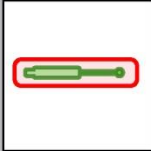
## Legende

	Airbag		Karosserie- verstärkung		Steuergerät
	Gas- generator		Überroll- schutz		Batterie
	Gurt- straffer		Gasdruck- dämpfer		Kraftstoff- tank

MICRA



# MICRA 5-Türer

Typ: K12, 2003-2010

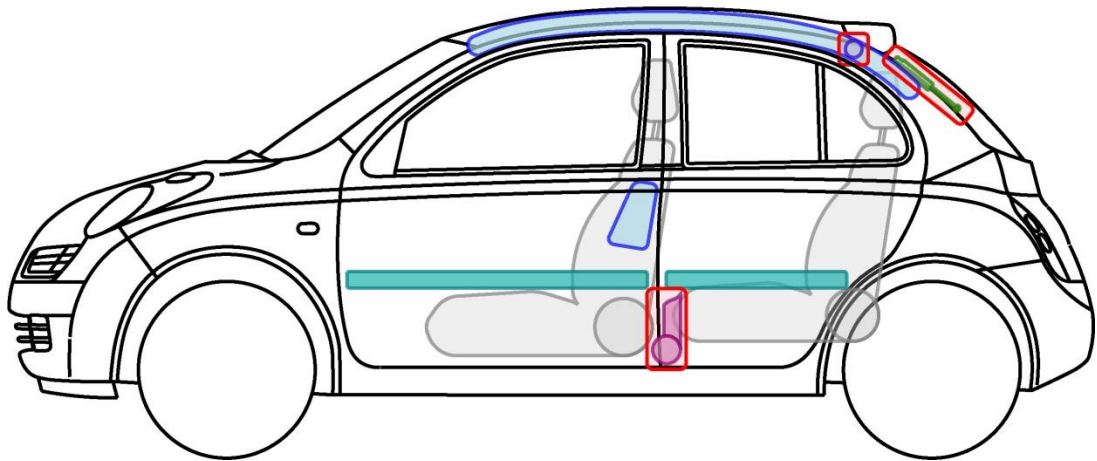
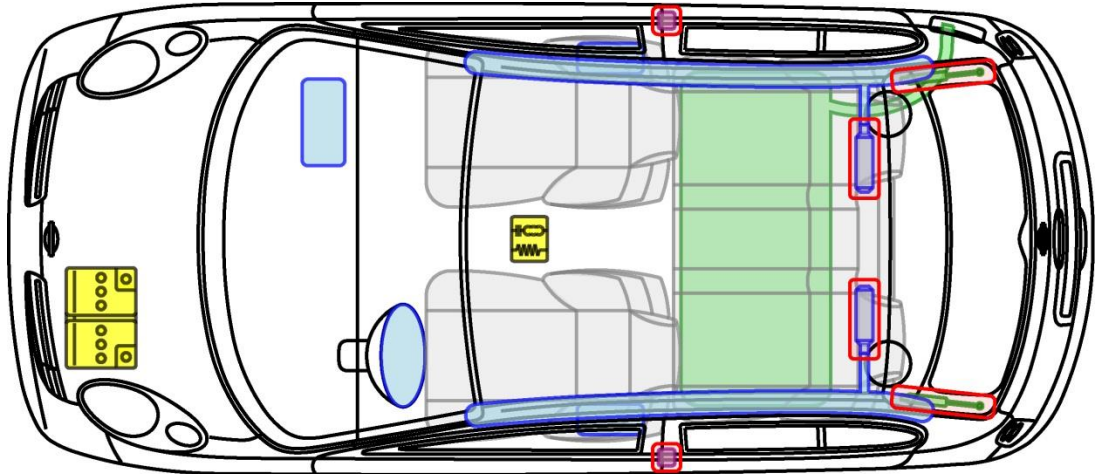

## Legende

	Airbag		Karosserie- verstärkung		Steuergerät
	Gas- generator		Überroll- schutz		Batterie
	Gurt- straffer		Gasdruck- dämpfer		Kraftstoff- tank

MICRA







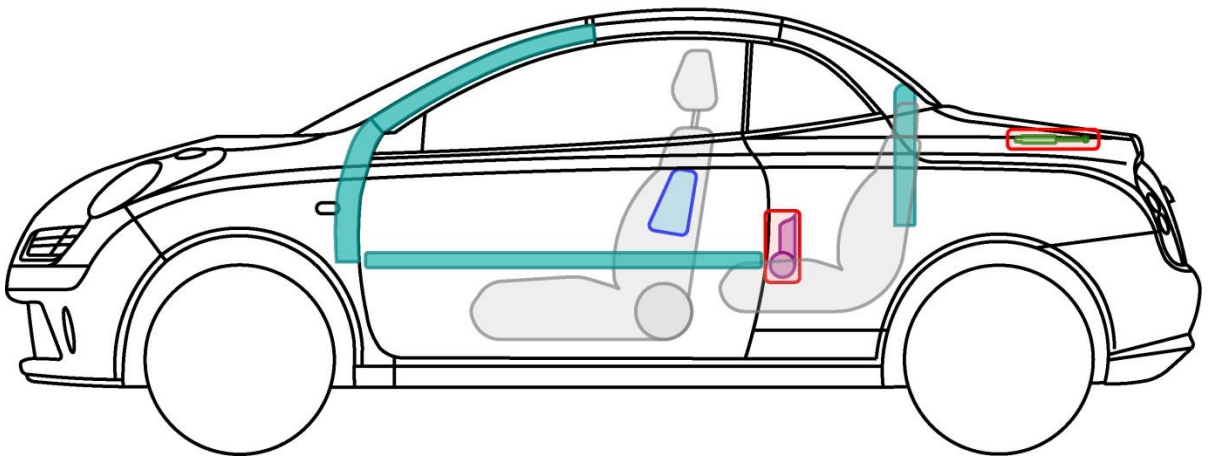
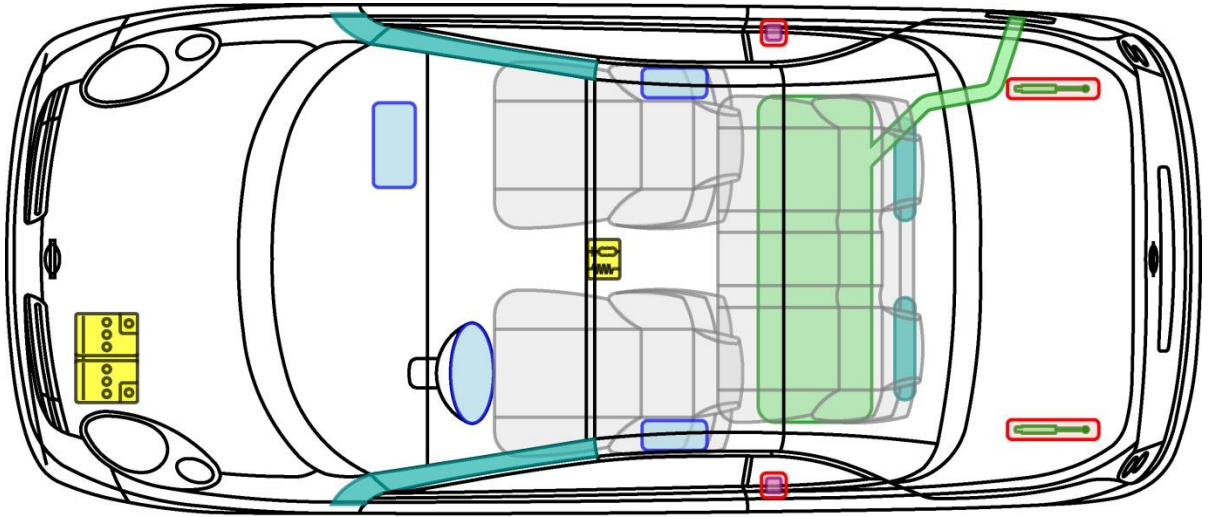

# MICRA C+C

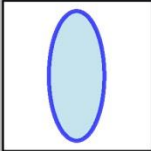
Typ: K12, 2005-2009

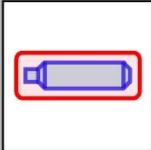

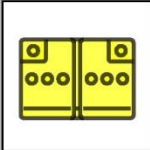
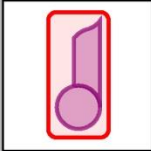
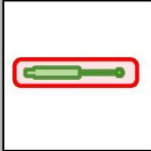
## Legende

	Airbag		Karosserie- verstärkung		Steuergerät
	Gas- generator		Überroll- schutz		Batterie
	Gurt- straffer		Gasdruck- dämpfer		Kraftstoff- tank

MICRA







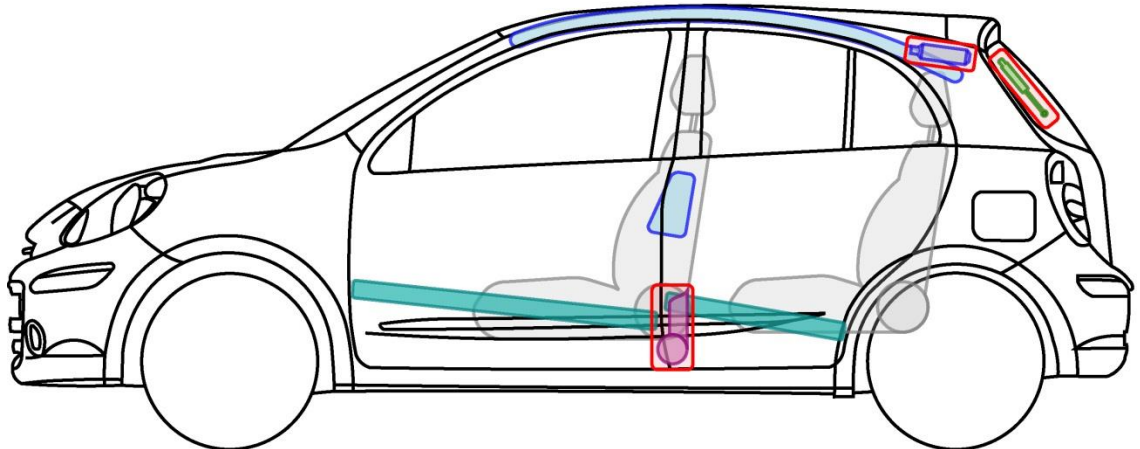
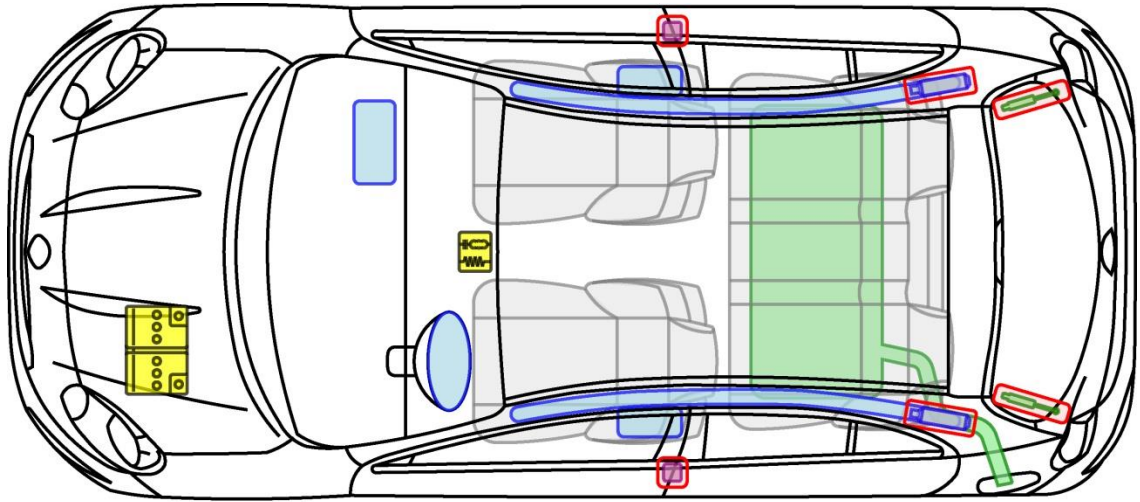

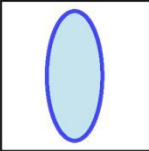

# MICRA 5-Türer

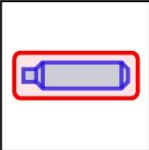
Typ: K13, 2010-

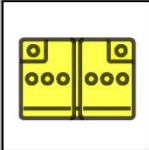

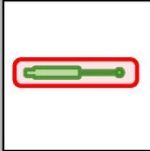
## Legende

	Airbag		Karosserie- verstärkung		Steuergerät
	Gas- generator		Überroll- schutz		Batterie
	Gurt- straffer		Gasdruck- dämpfer		Kraftstoff- tank







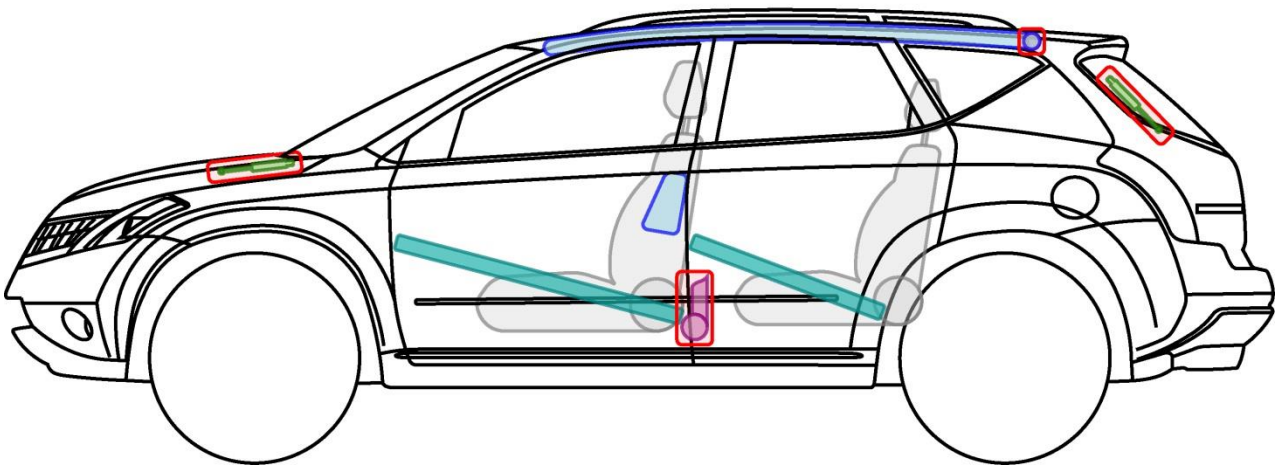
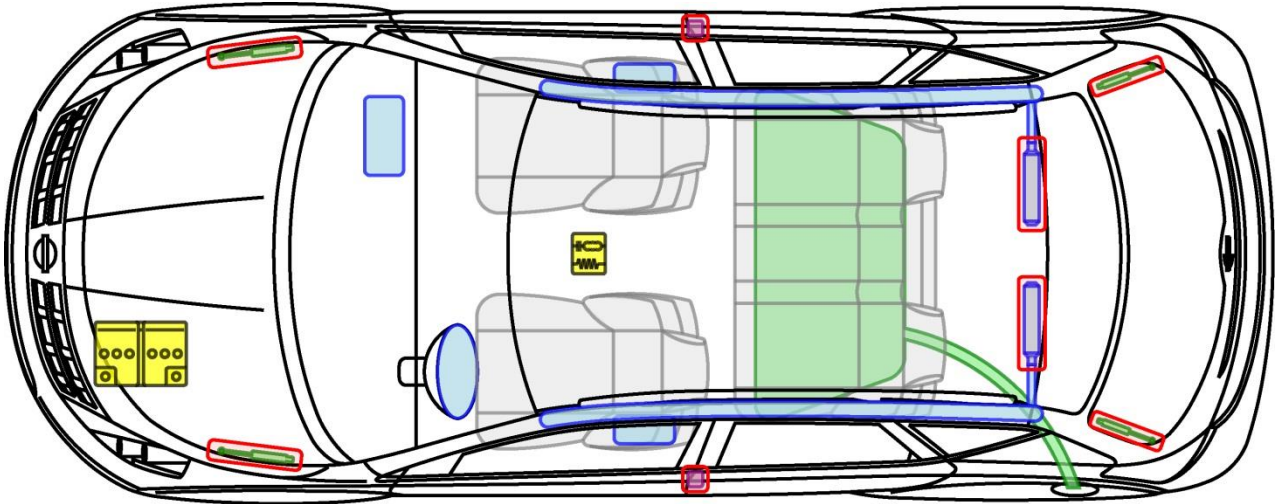

# MURANO

Typ: Z50, 2005-2008

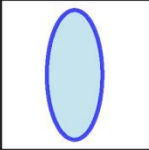
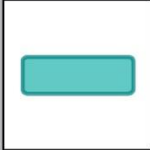

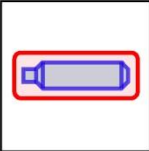
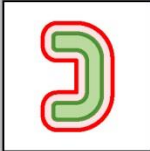
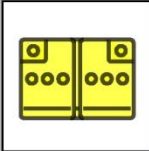
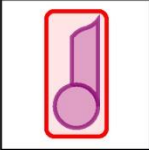
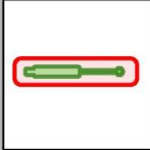
## Legende

	Airbag		Karosserie- verstärkung		Steuergerät
	Gas- generator		Überroll- schutz		Batterie
	Gurt- straffer		Gasdruck- dämpfer		Kraftstoff- tank

**MURANO**







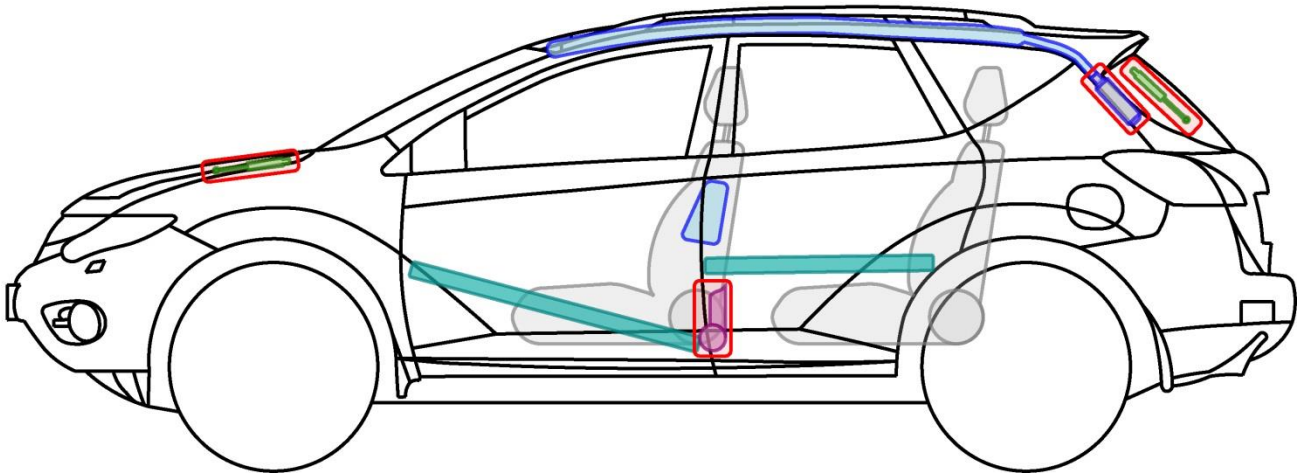
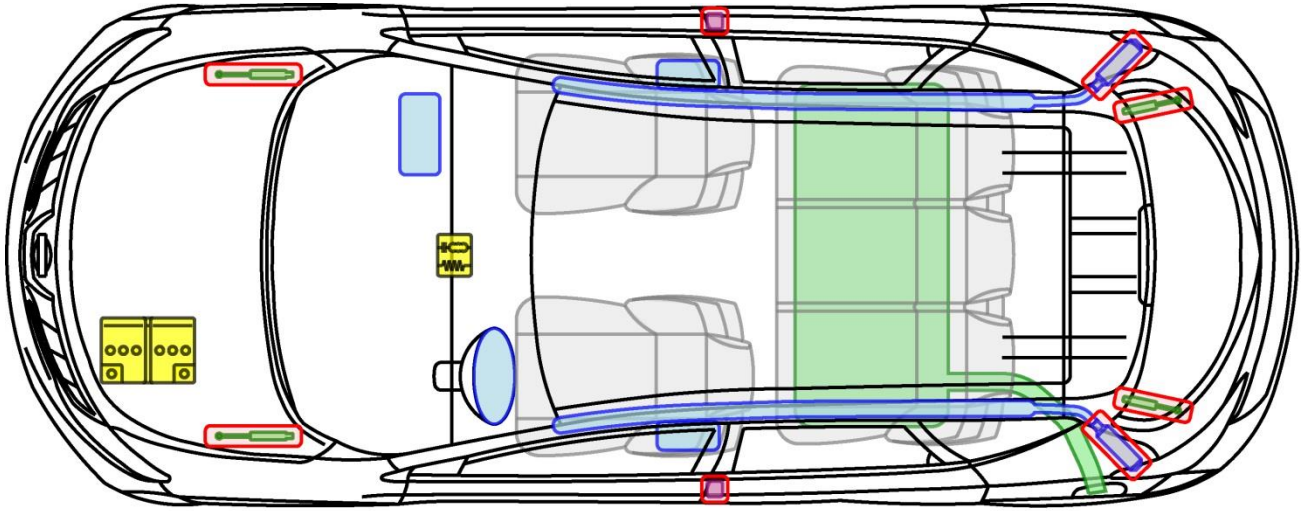

# MURANO

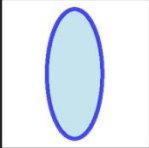
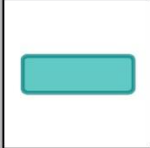
Typ: Z51, 2008-

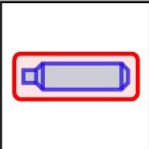

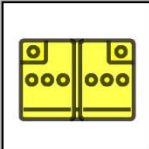
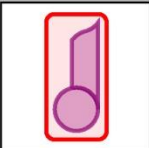
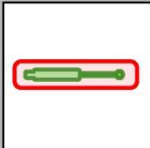
## Legende

	Airbag		Karosserie- verstärkung		Steuergerät
	Gas- generator		Überroll- schutz		Batterie
	Gurt- straffer		Gasdruck- dämpfer		Kraftstoff- tank

**MURANO**







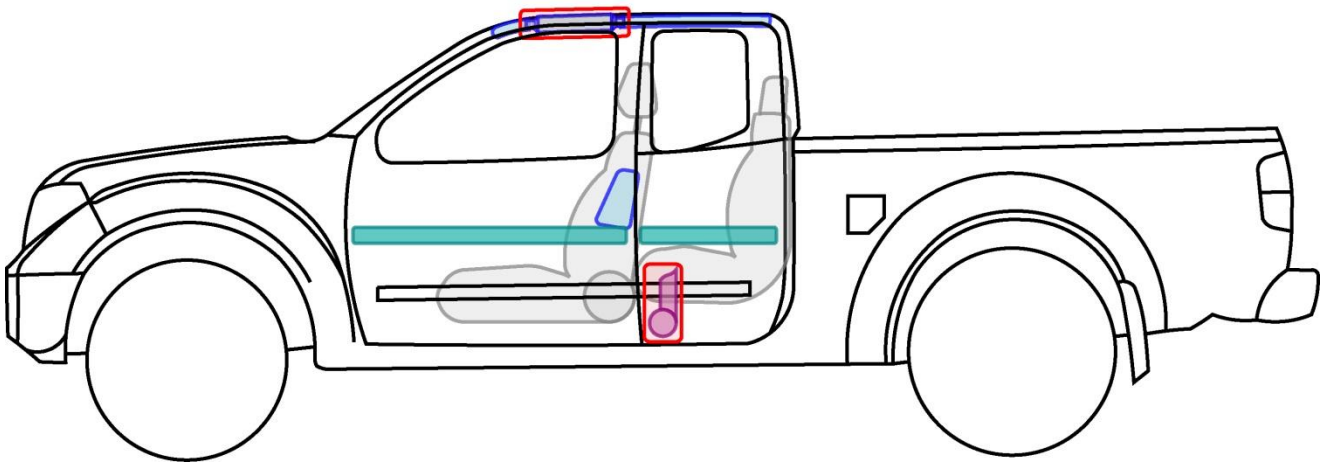
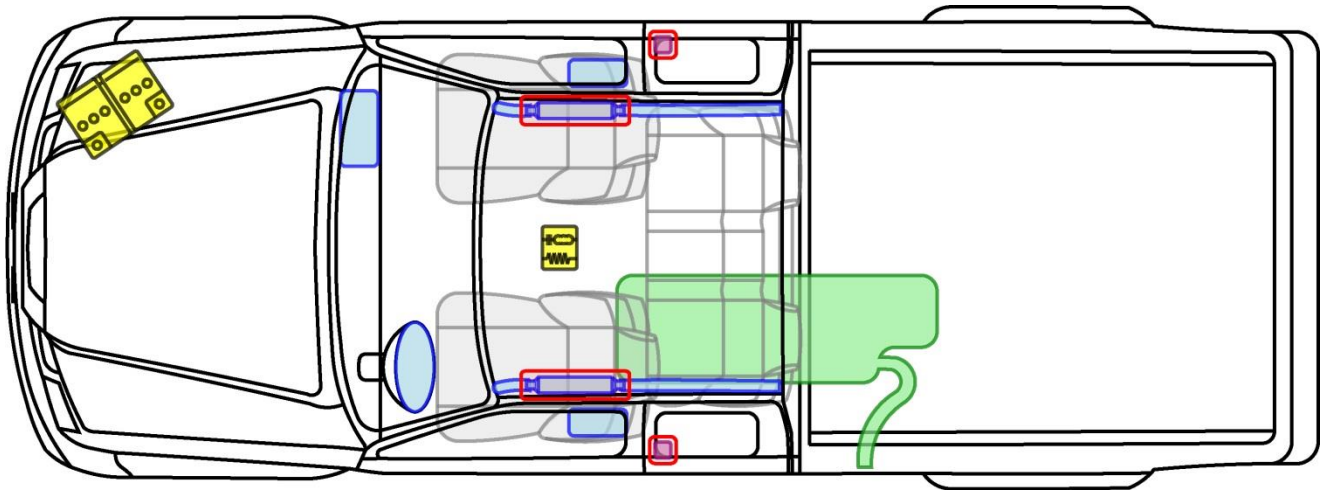

# NAVARA King Cab

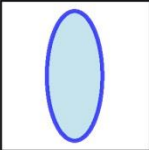
Typ: D40, 2005-

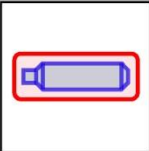
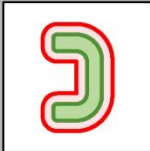
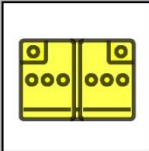

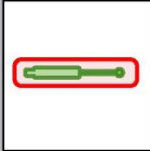
## Legende

	Airbag		Karosserie- verstärkung		Steuergerät
	Gas- generator		Überroll- schutz		Batterie
	Gurt- straffer		Gasdruck- dämpfer		Kraftstoff- tank











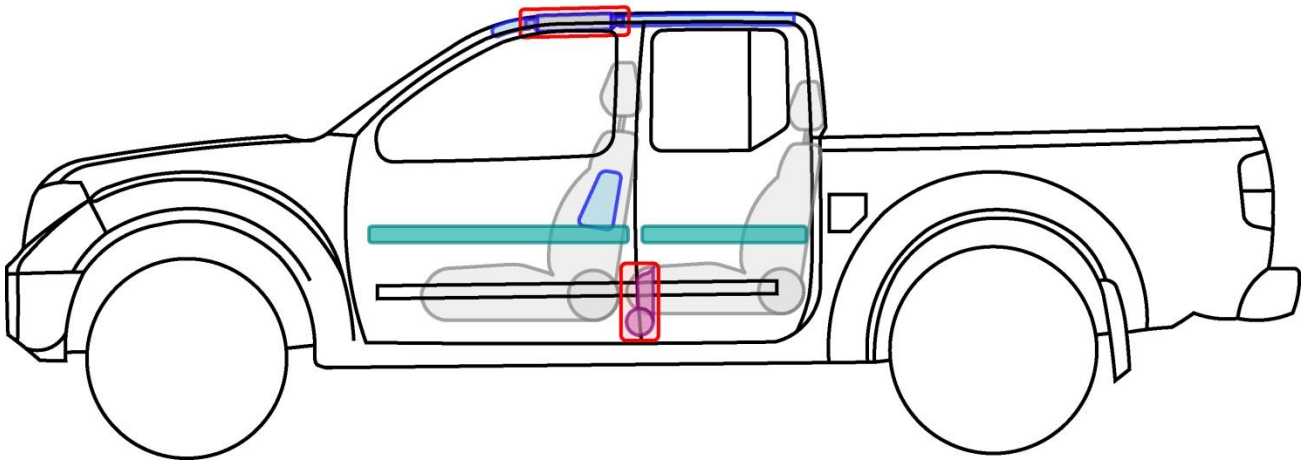
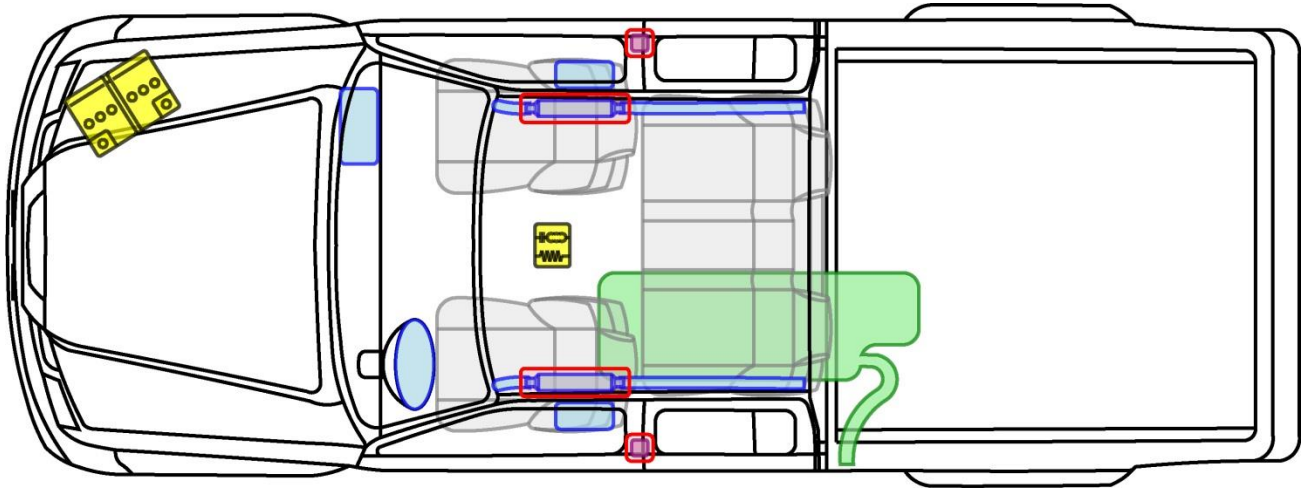

# NAVARA Crew Cab

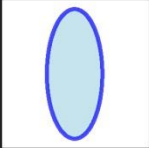
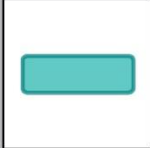
Typ: D40, 2005-

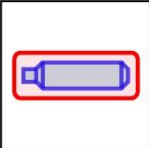

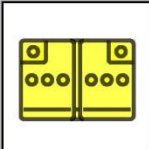
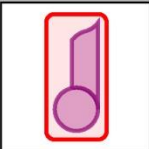
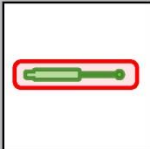
## Legende

	Airbag		Karosserie- verstärkung		Steuergerät
	Gas- generator		Überroll- schutz		Batterie
	Gurt- straffer		Gasdruck- dämpfer		Kraftstoff- tank









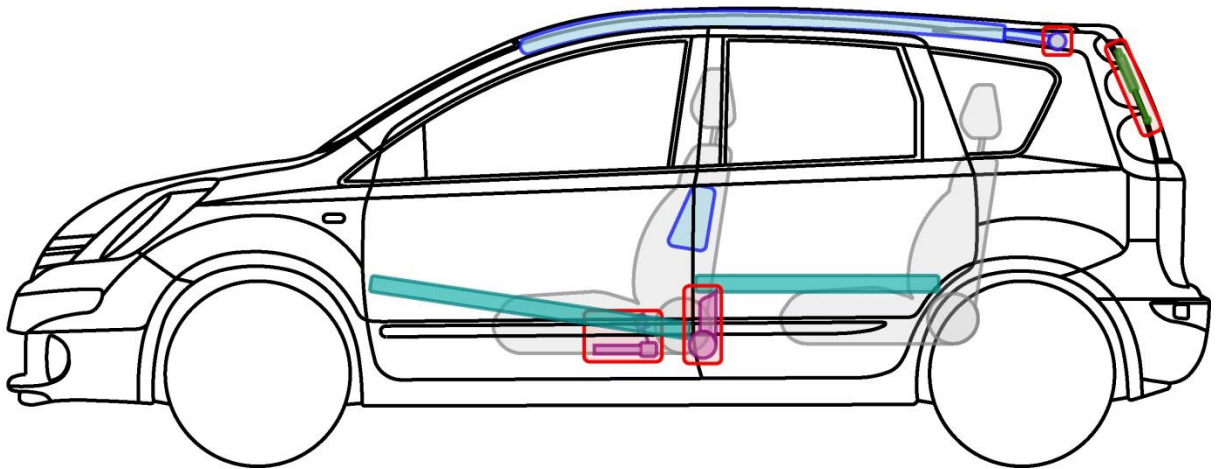
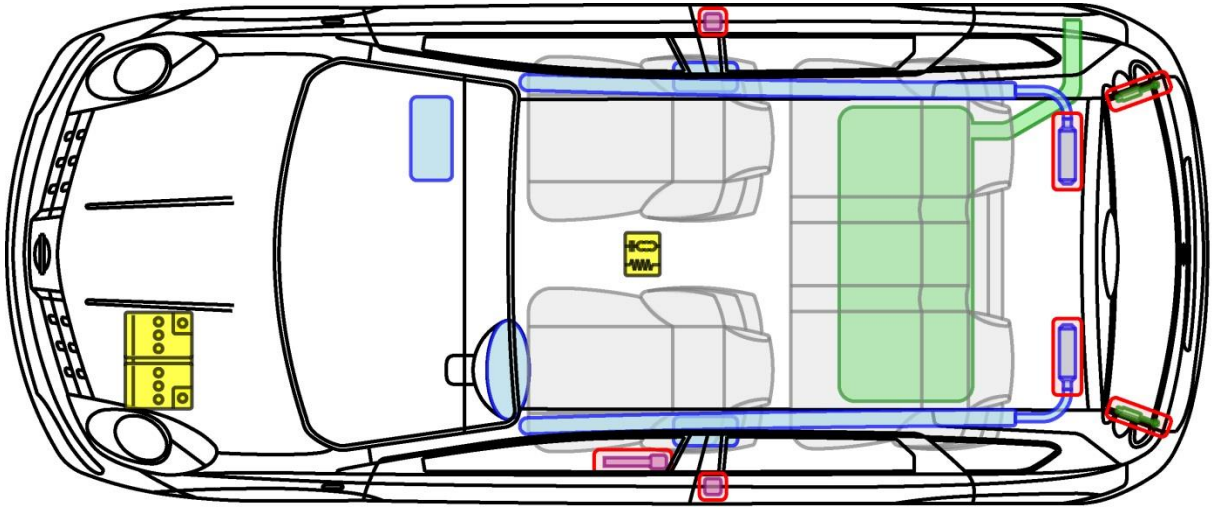

# NOTE

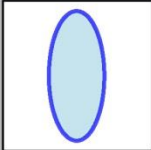
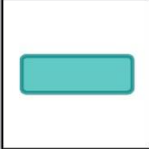
Typ: E11, 2006-2013

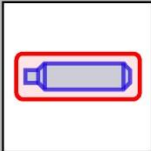

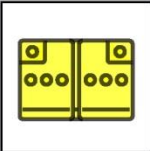
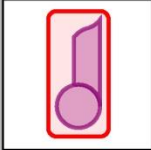
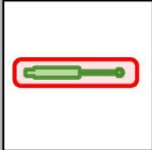
## Legende

	Airbag		Karosserie- verstärkung		Steuergerät
	Gas- generator		Überroll- schutz		Batterie
	Gurt- straffer		Gasdruck- dämpfer		Kraftstoff- tank

NOTE



# NOTE

Typ: E12, 2013-

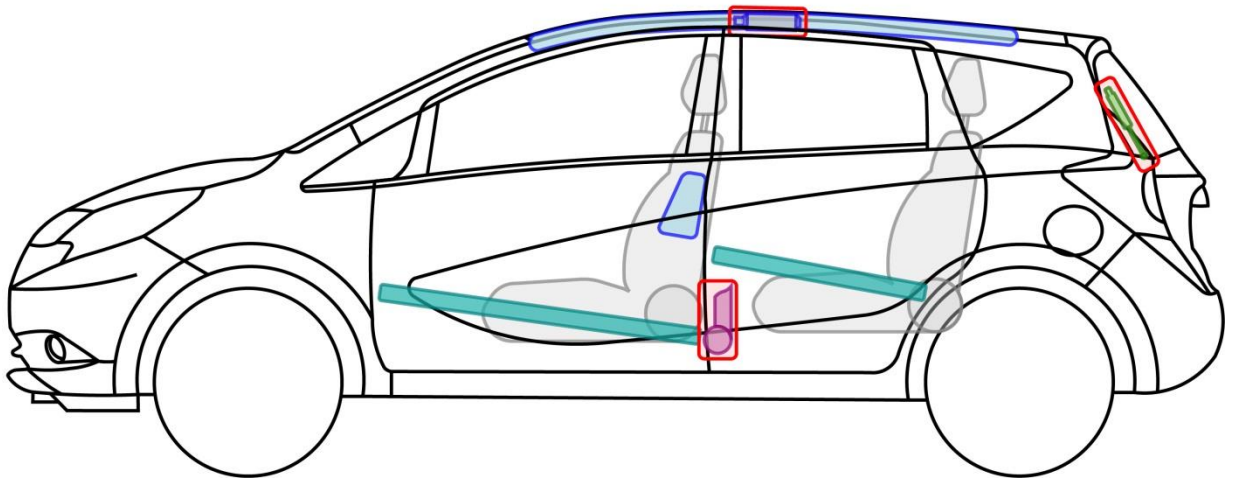
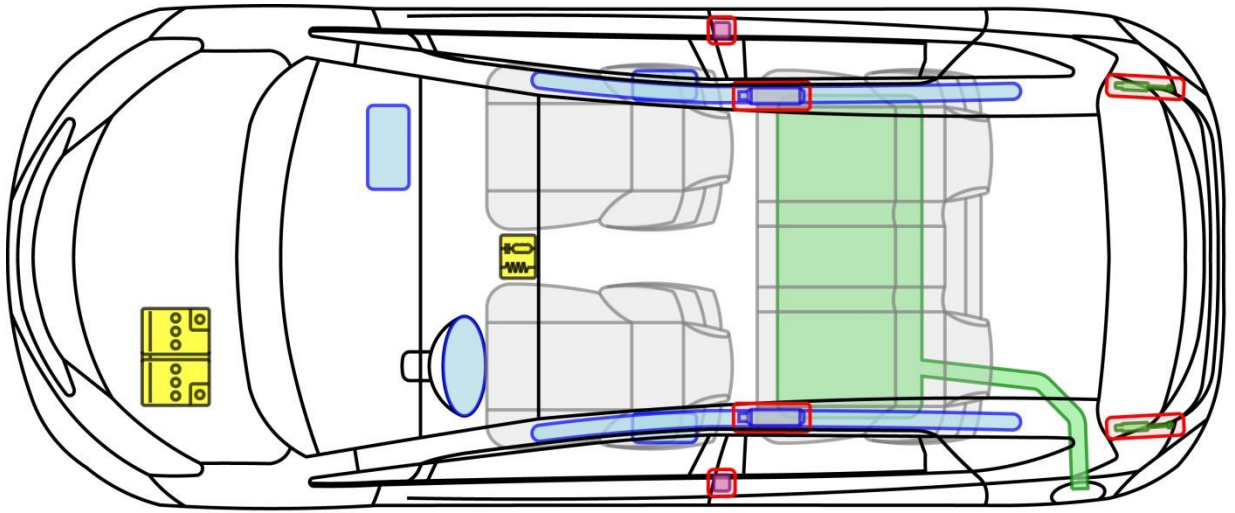

## Legende

	Airbag		Karosserie- verstärkung		Steuergerät
	Gas- generator		Überroll- schutz		Batterie
	Gurt- straffer		Gasdruck- dämpfer		Kraftstoff- tank

NOTE







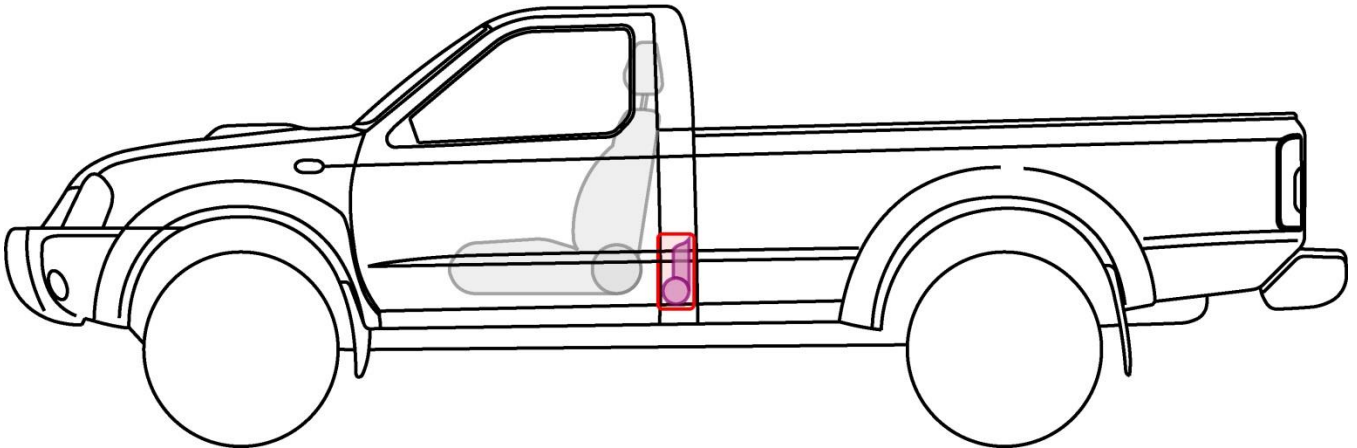
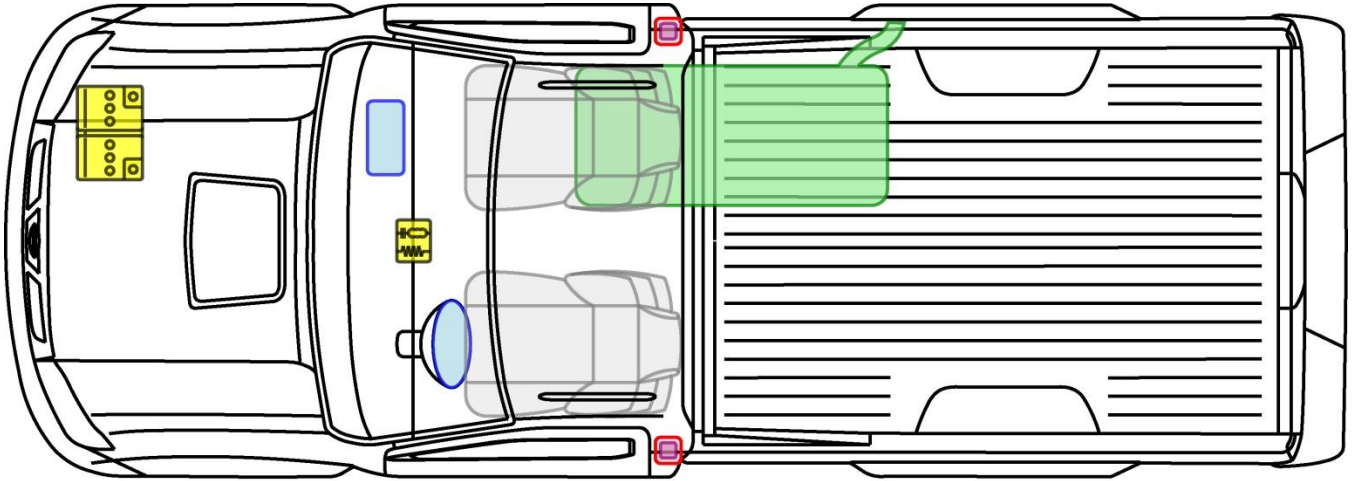

# NP300 Single Cab

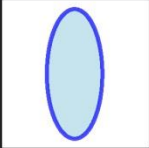
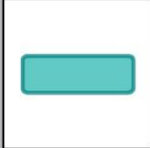
Typ: D22, 2008-

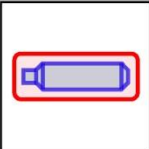

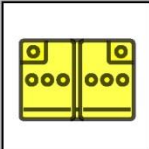
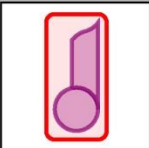
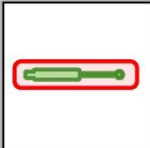
## Legende

	Airbag		Karosserie- verstärkung		Steuergerät
	Gas- generator		Überroll- schutz		Batterie
	Gurt- straffer		Gasdruck- dämpfer		Kraftstoff- tank

NP300







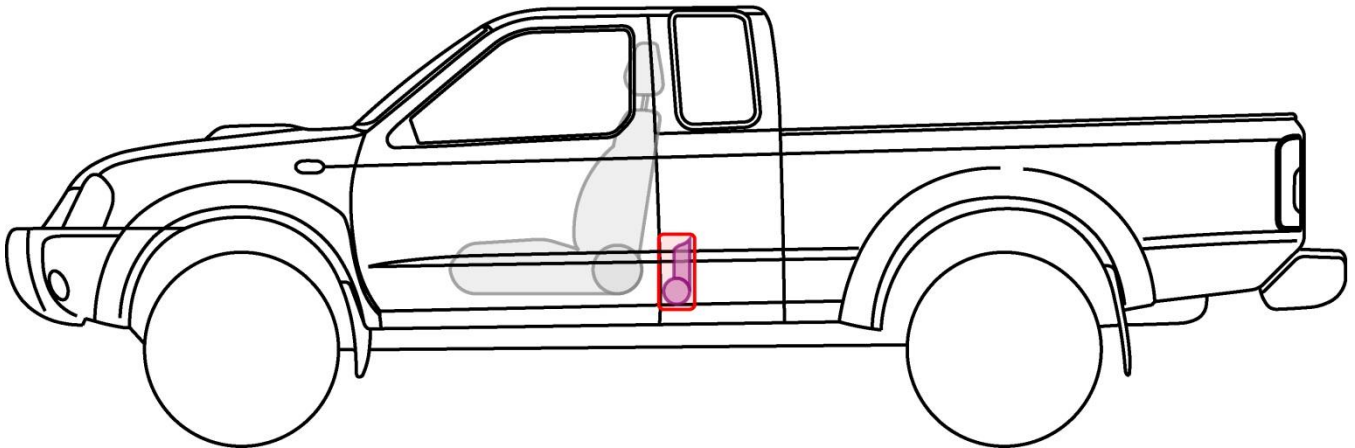
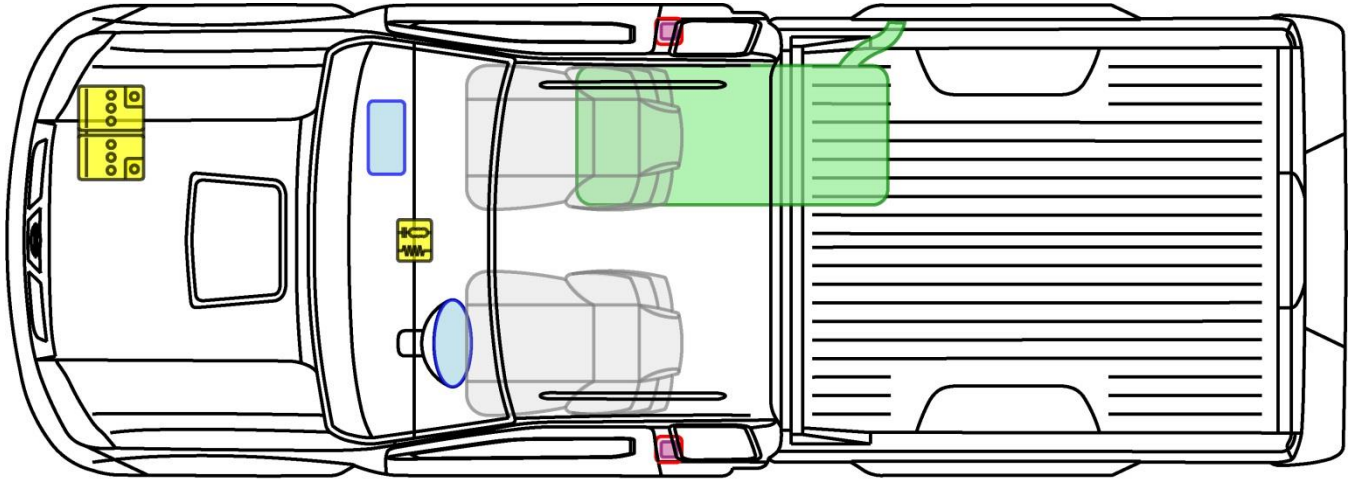

# NP300 King Cab

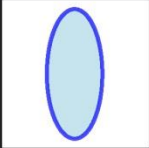
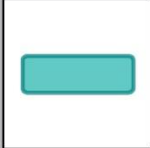
Typ: D22, 2008-

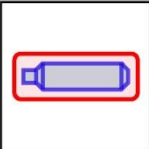

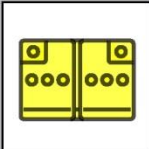
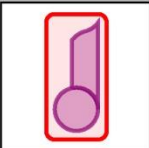
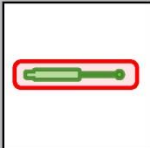
## Legende

	Airbag		Karosserie- verstärkung		Steuergerät
	Gas- generator		Überroll- schutz		Batterie
	Gurt- straffer		Gasdruck- dämpfer		Kraftstoff- tank

NP300







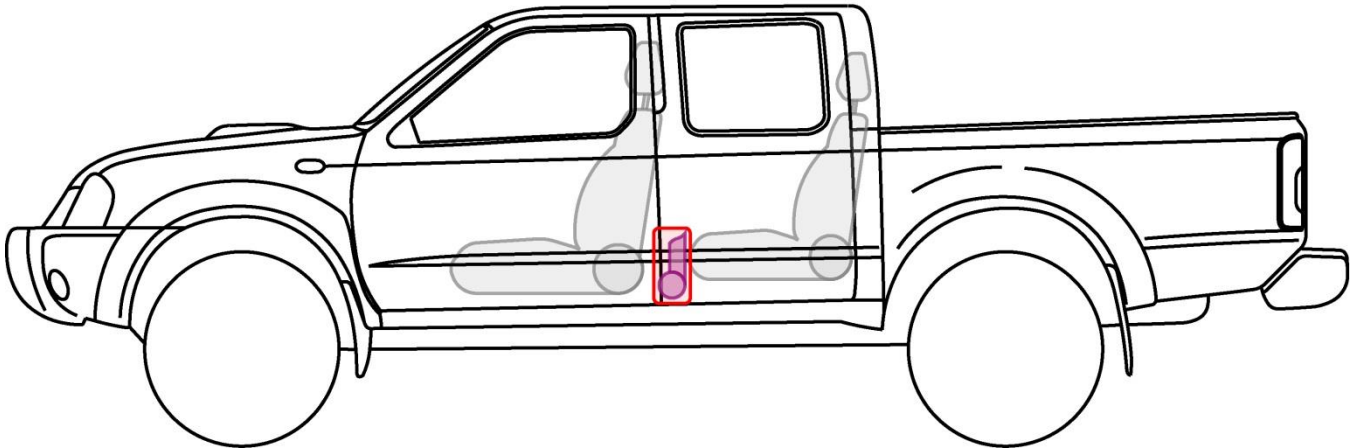
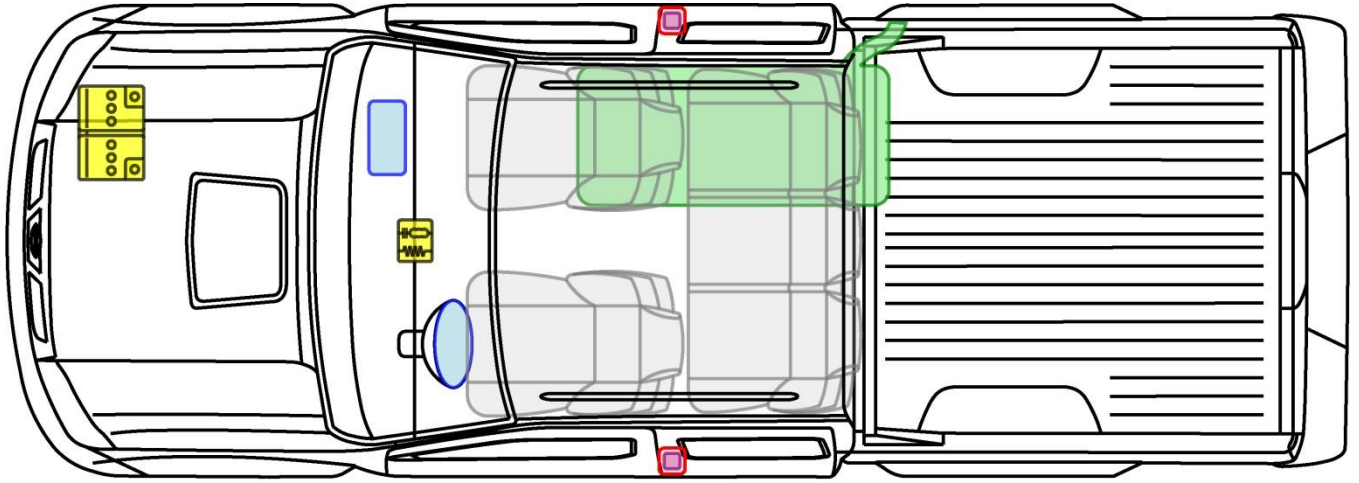

# NP300 Double Cab

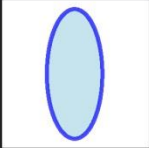
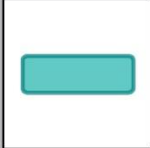
Typ: D22, 2008-

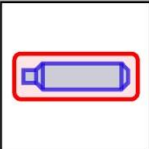

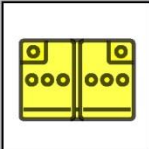
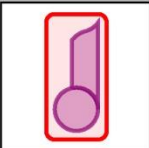
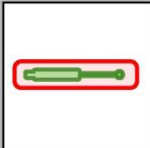
## Legende

	Airbag		Karosserie- verstärkung		Steuergerät
	Gas- generator		Überroll- schutz		Batterie
	Gurt- straffer		Gasdruck- dämpfer		Kraftstoff- tank

NP300



# NV200

Typ: M20, 2009-

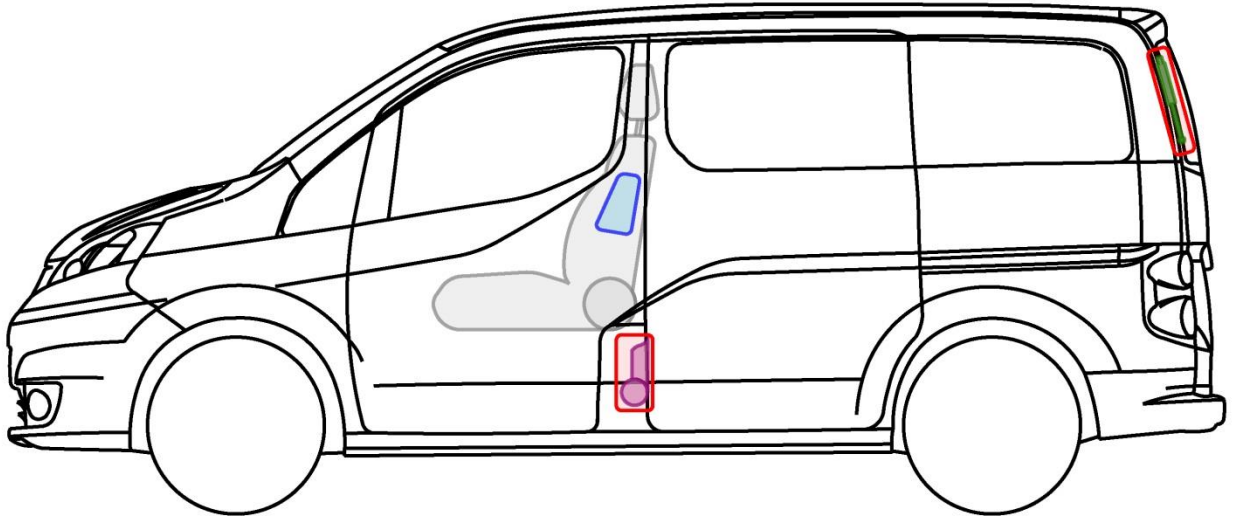
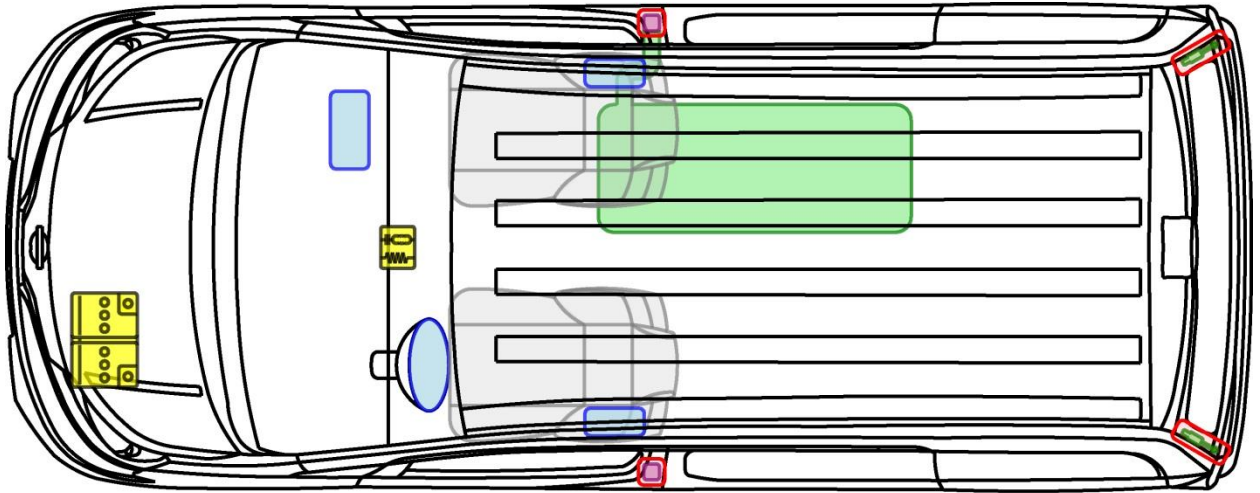

## Legende

	Airbag		Karosserie- verstärkung		Steuergerät
	Gas- generator		Überroll- schutz		Batterie
	Gurt- straffer		Gasdruck- dämpfer		Kraftstoff- tank

NV200



# NV400

Typ: M9, 2011-

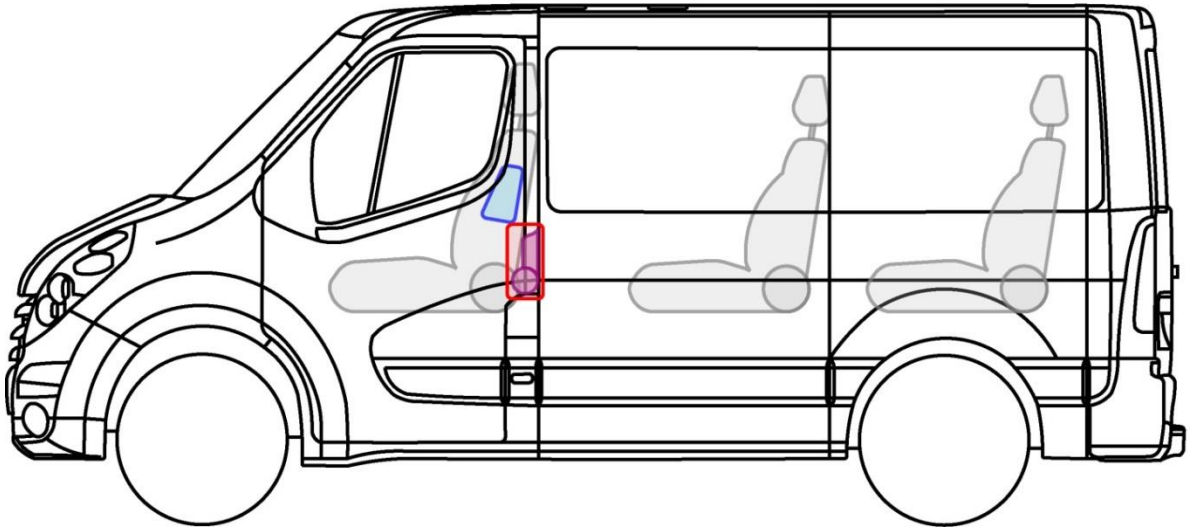
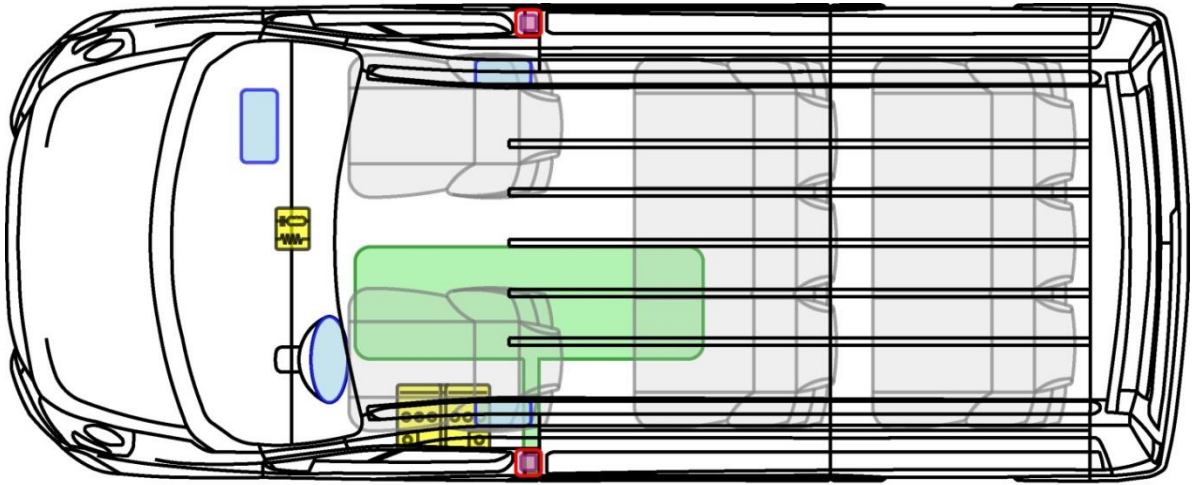

## Legende

	Airbag		Karosserie- verstärkung		Steuergerät
	Gas- generator		Überroll- schutz		Batterie
	Gurt- straffer		Gasdruck- dämpfer		Kraftstoff- tank

NV400





# PATHFINDER

Typ: R51, 2005-

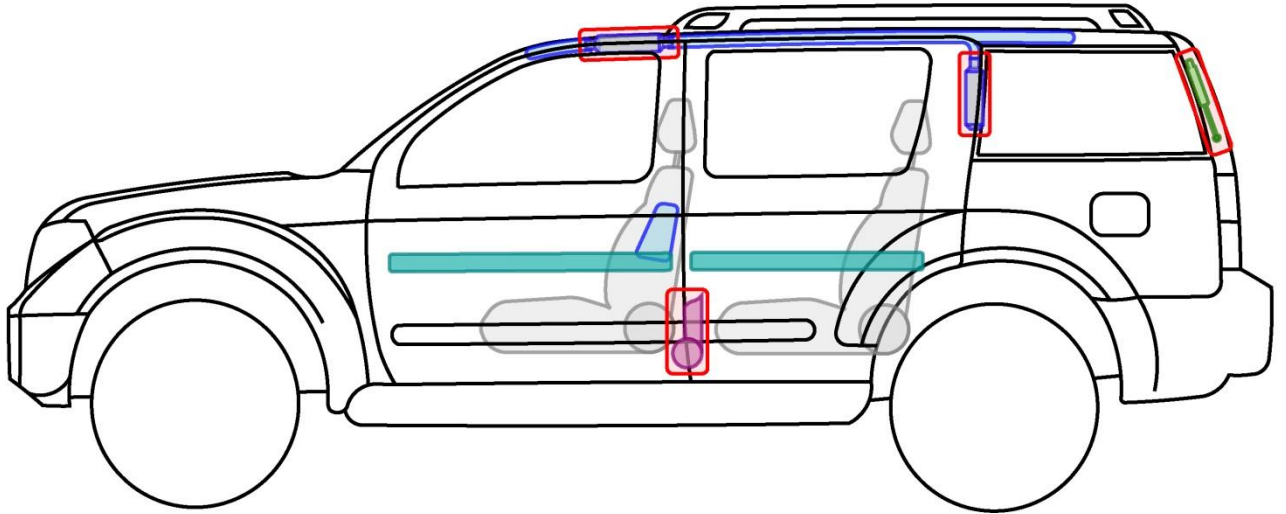
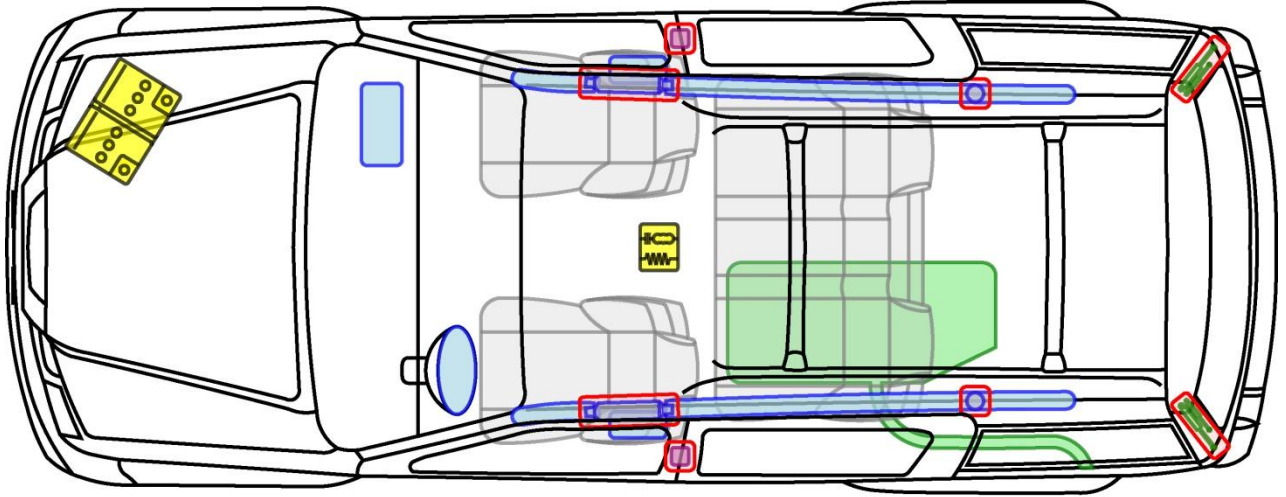

## Legende

	Airbag		Karosserie-verstärkung		Steuergerät
	Gas-generator		Überroll-schutz		Batterie
	Gurt-straffer		Gasdruck-dämpfer		Kraftstoff-tank

PATHFINDER







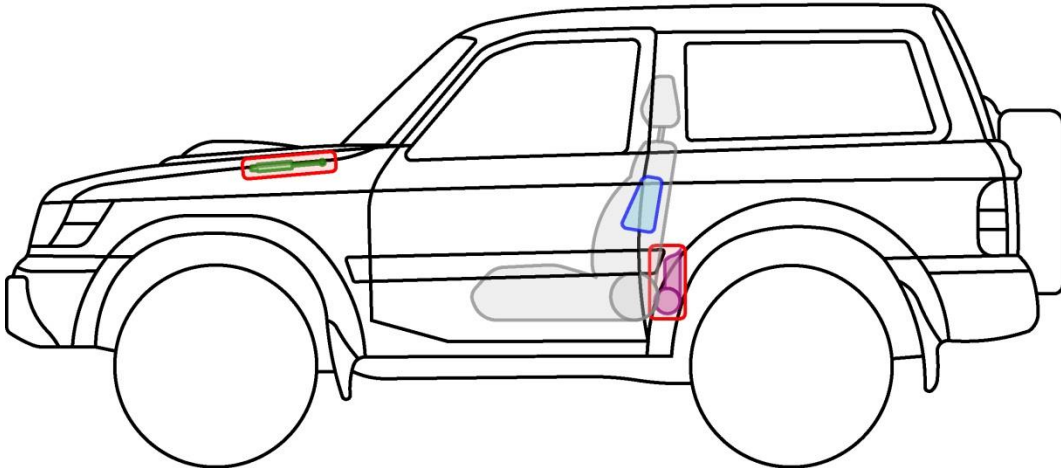
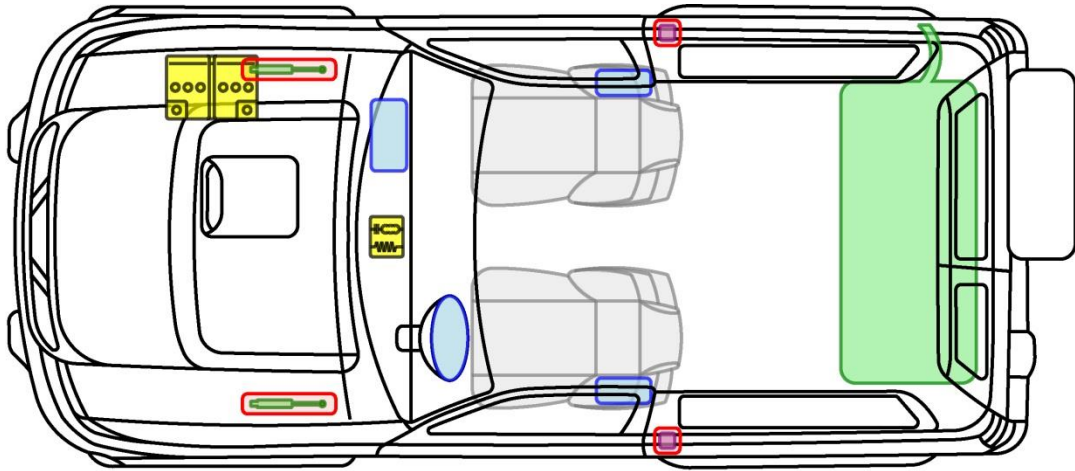

# PATROL 3-Türer

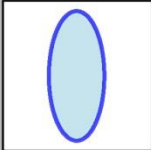
Typ: Y61, 2000-

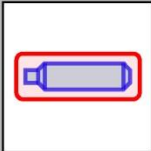

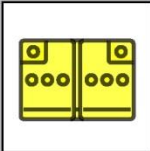
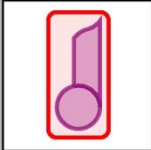
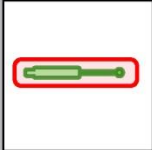
## Legende

	Airbag		Karosserie- verstärkung		Steuergerät
	Gas- generator		Überroll- schutz		Batterie
	Gurt- straffer		Gasdruck- dämpfer		Kraftstoff- tank

PATROL







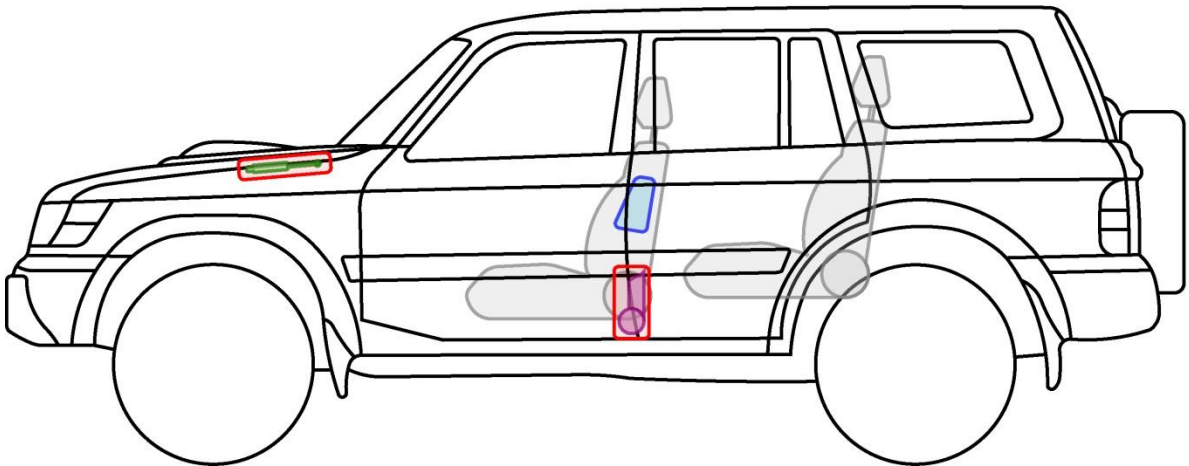
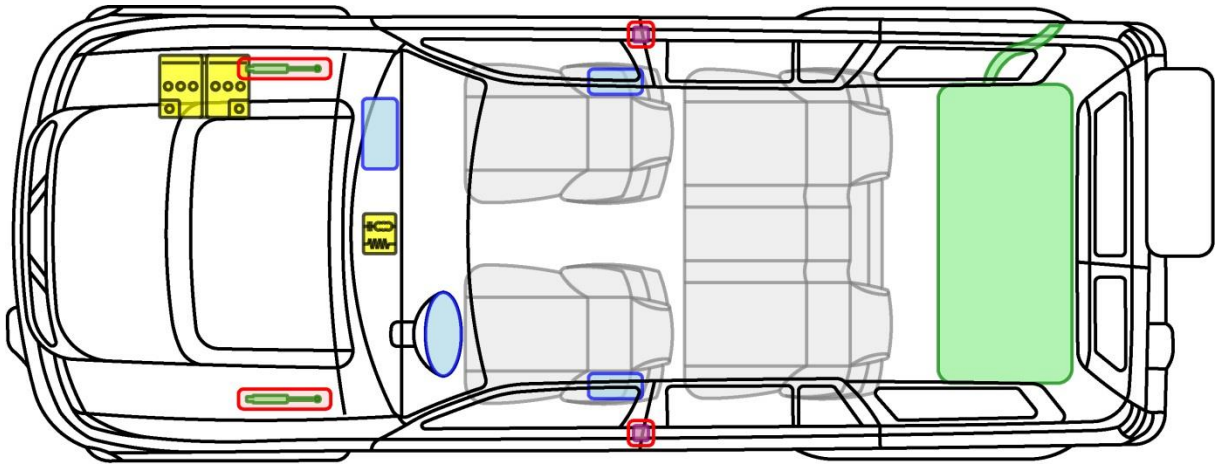

# PATROL 5-Türer

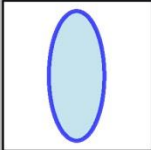
Typ: Y61, 2000-

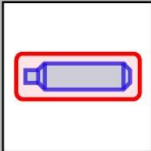

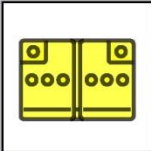
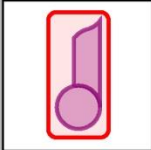
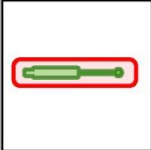
## Legende

	Airbag		Karosserie- verstärkung		Steuergerät
	Gas- generator		Überroll- schutz		Batterie
	Gurt- straffer		Gasdruck- dämpfer		Kraftstoff- tank

PATROL







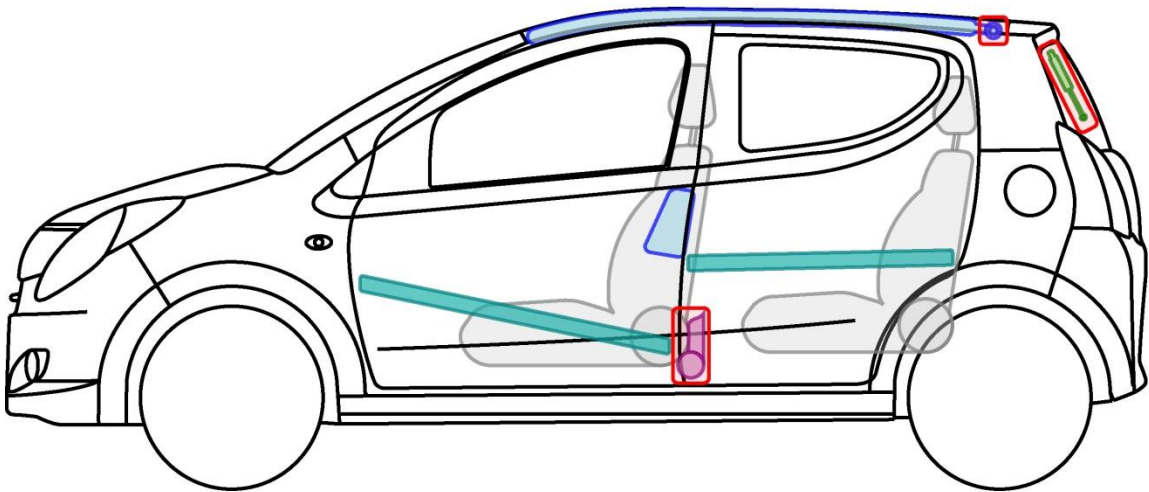
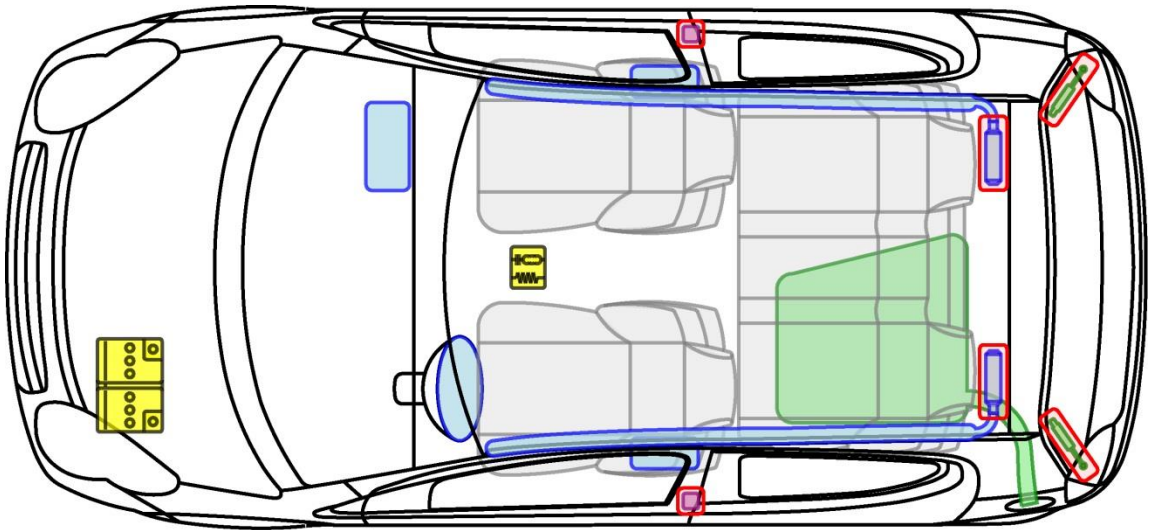

# PIXO

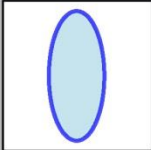
Typ: UA0, 2009-

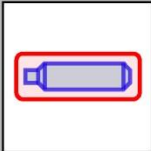

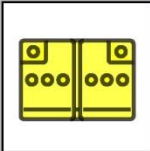
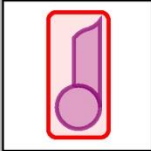
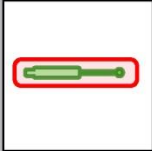
## Legende

	Airbag		Karosserie- verstärkung		Steuergerät
	Gas- generator		Überroll- schutz		Batterie
	Gurt- straffer		Gasdruck- dämpfer		Kraftstoff- tank









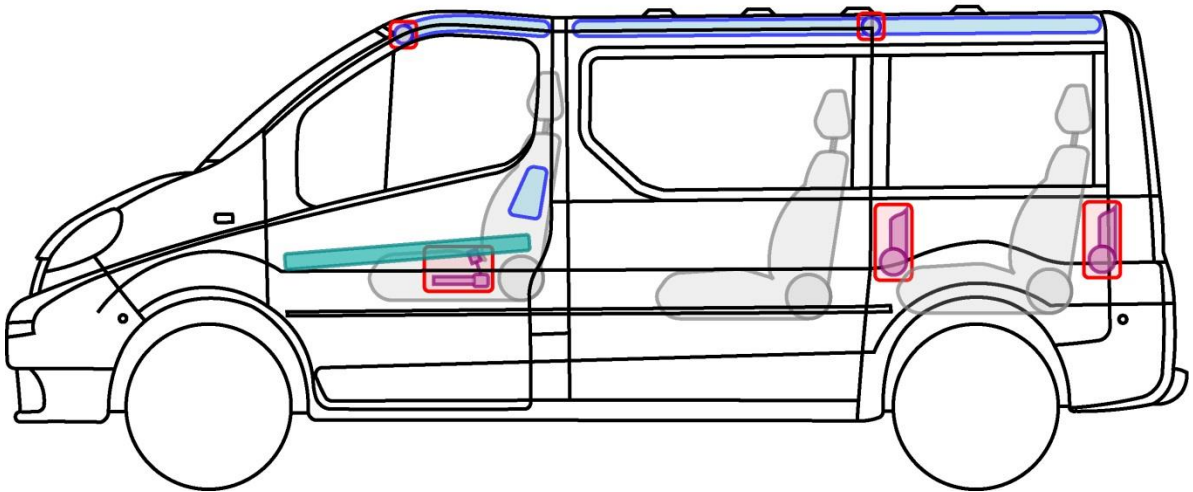
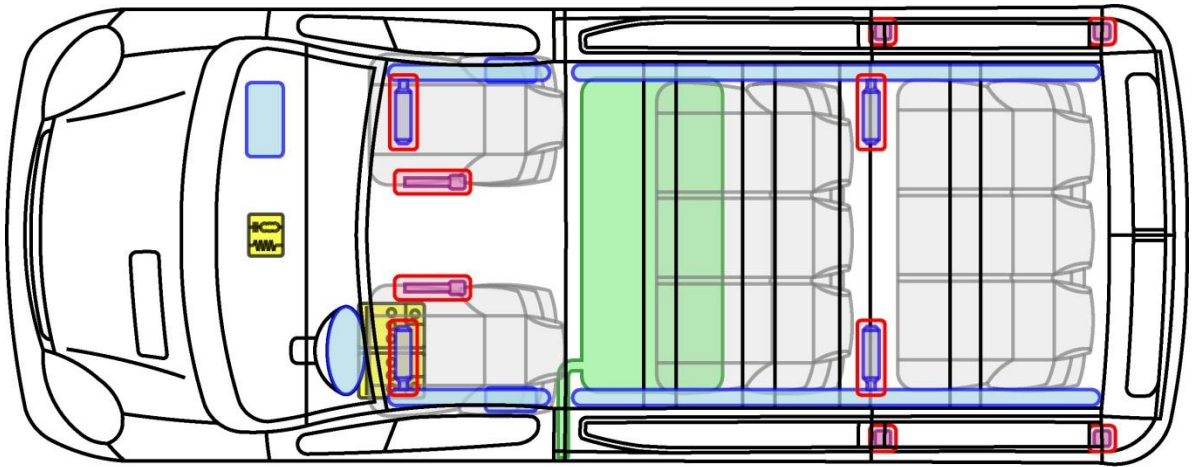

# PRIMASTAR

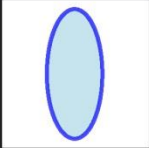
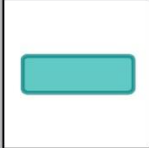
Typ: X83, 2003-

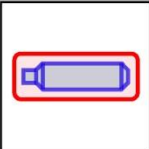

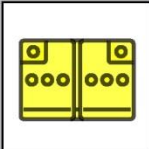
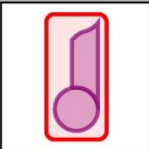
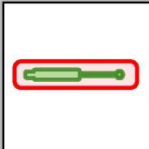
## Legende

	Airbag		Karosserie- verstärkung		Steuergerät
	Gas- generator		Überroll- schutz		Batterie
	Gurt- straffer		Gasdruck- dämpfer		Kraftstoff- tank

PRIMASTAR







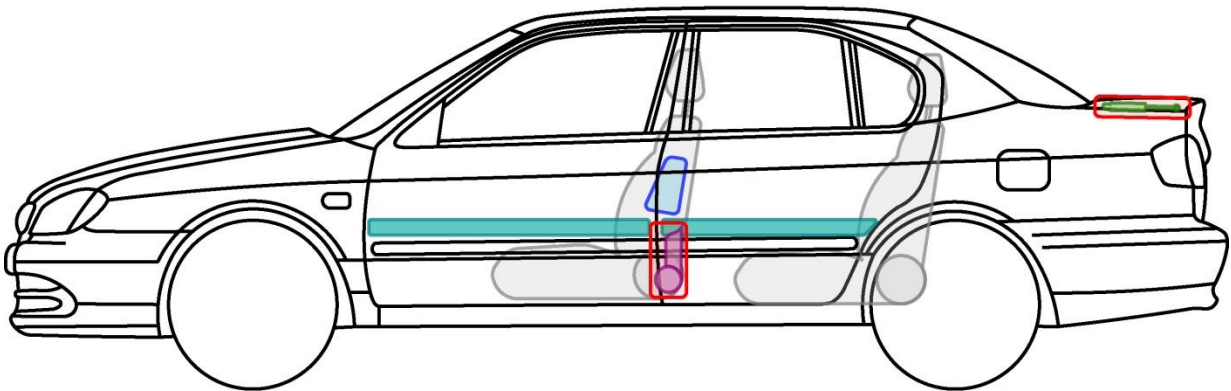
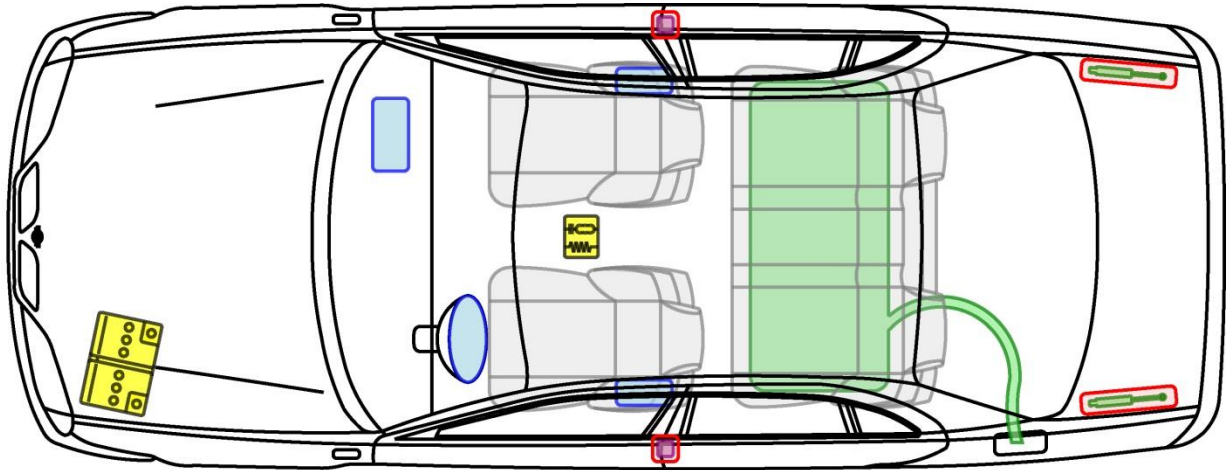

# PRIMERA 4-Türer

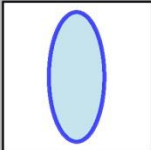
Typ: P11, 1994-2002

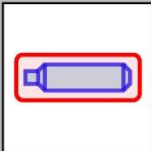

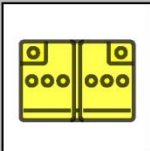
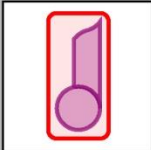
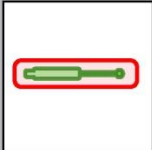
## Legende

	Airbag		Karosserie- verstärkung		Steuergerät
	Gas- generator		Überroll- schutz		Batterie
	Gurt- straffer		Gasdruck- dämpfer		Kraftstoff- tank

PRIMERA



# PRIMERA 5-Türer

Typ: P11, 1994-2002

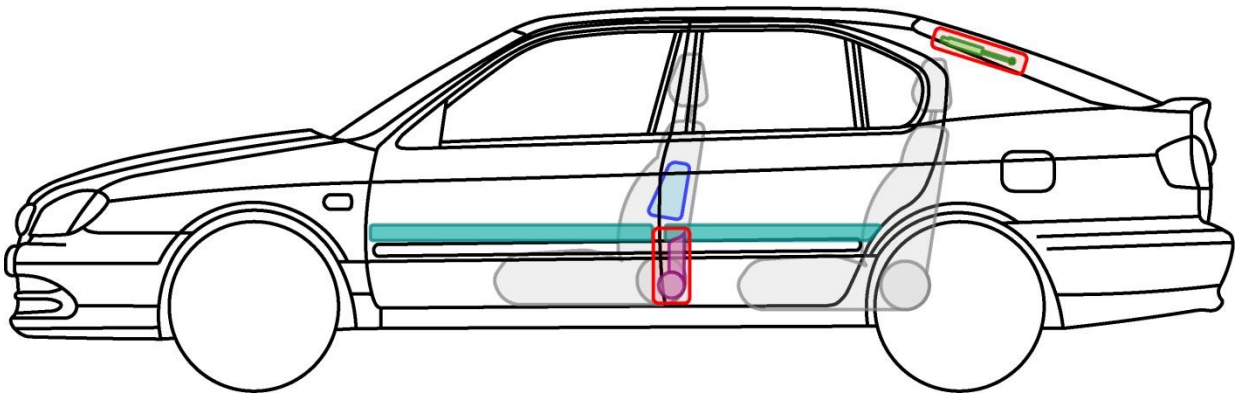
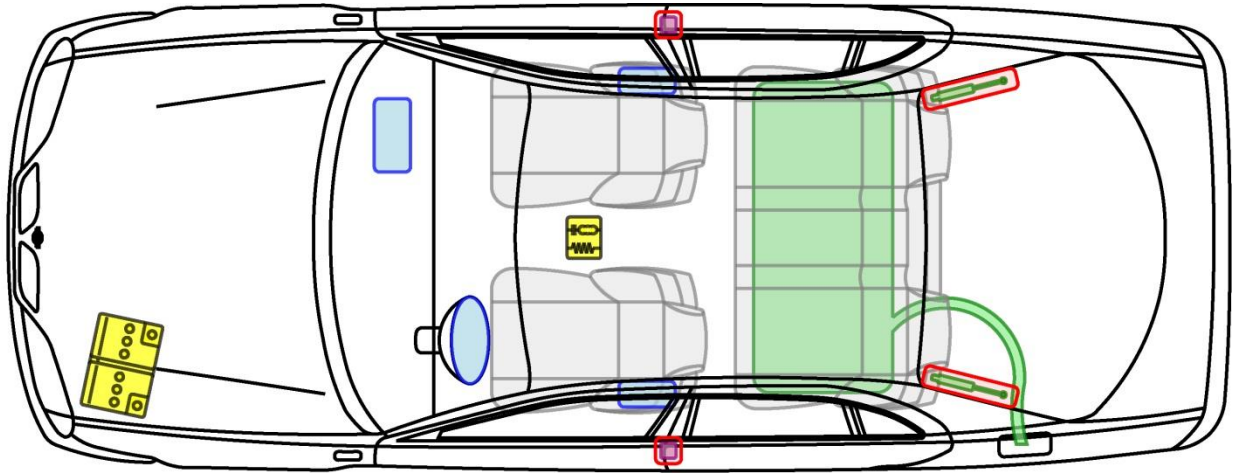

## Legende

	Airbag		Karosserie- verstärkung		Steuergerät
	Gas- generator		Überroll- schutz		Batterie
	Gurt- straffer		Gasdruck- dämpfer		Kraftstoff- tank

PRIMERA



# PRIMERA Kombi

Typ: P11, 1994-2002

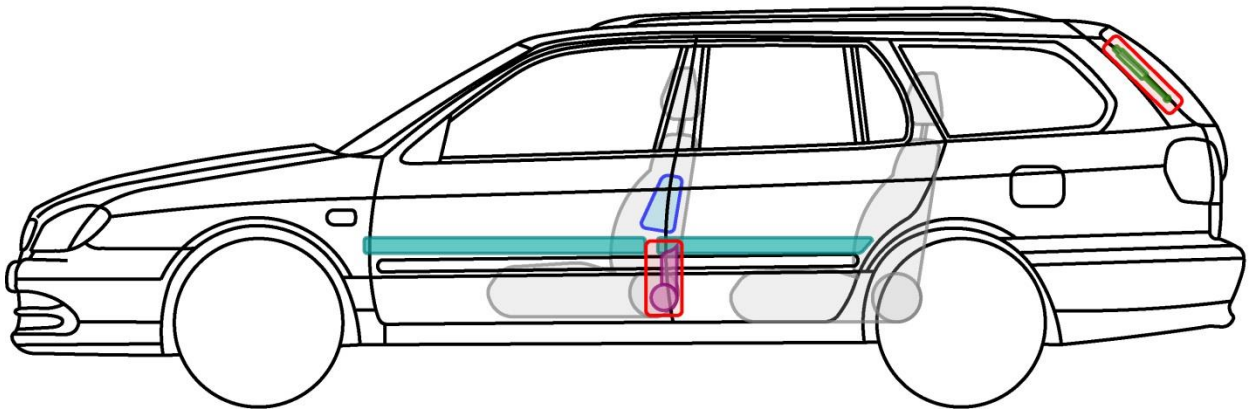
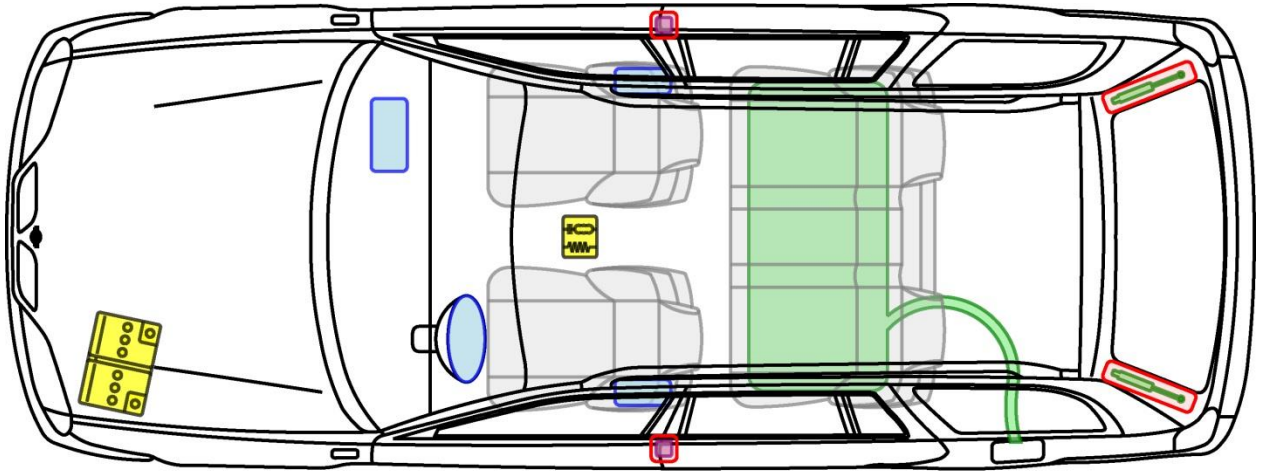

## Legende

	Airbag		Karosserie- verstärkung		Steuergerät
	Gas- generator		Überroll- schutz		Batterie
	Gurt- straffer		Gasdruck- dämpfer		Kraftstoff- tank

PRIMERA









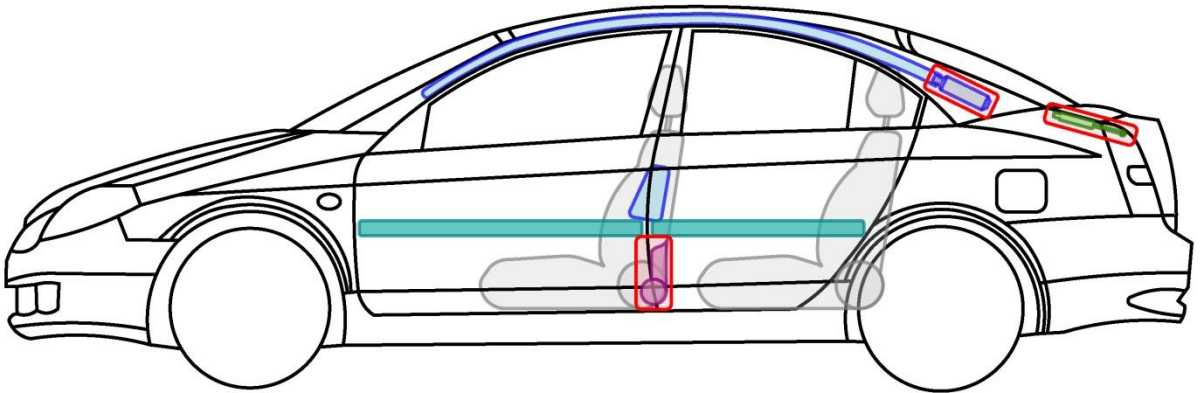
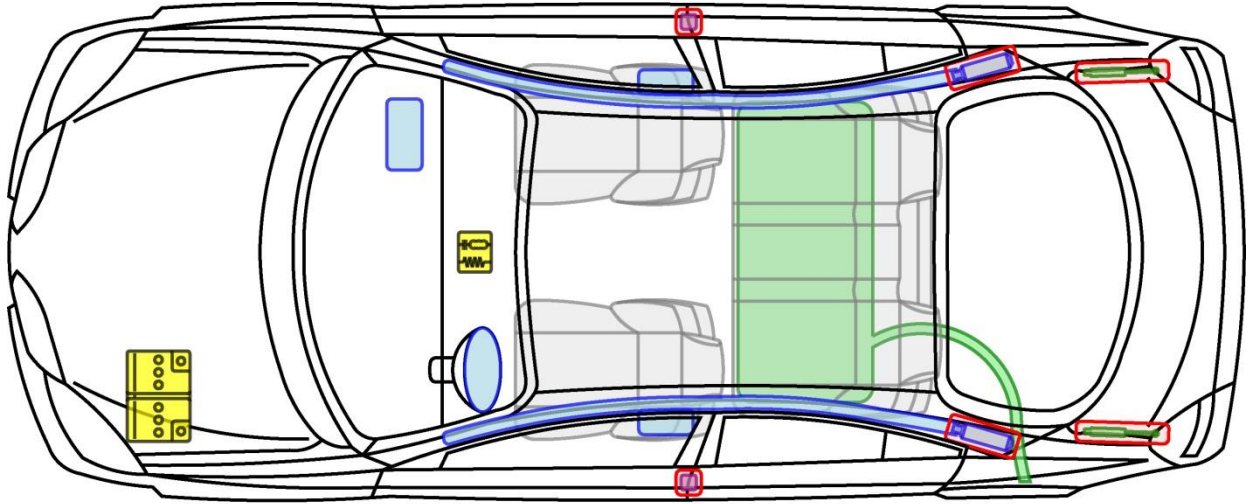

# PRIMERA 4-Türer

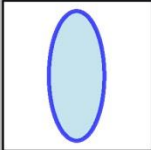
Typ: P12, 2002-2008

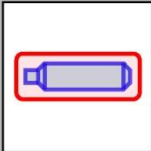

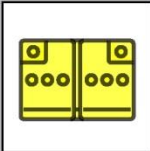
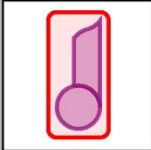
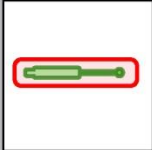
## Legende

	Airbag		Karosserie- verstärkung		Steuergerät
	Gas- generator		Überroll- schutz		Batterie
	Gurt- straffer		Gasdruck- dämpfer		Kraftstoff- tank

PRIMERA





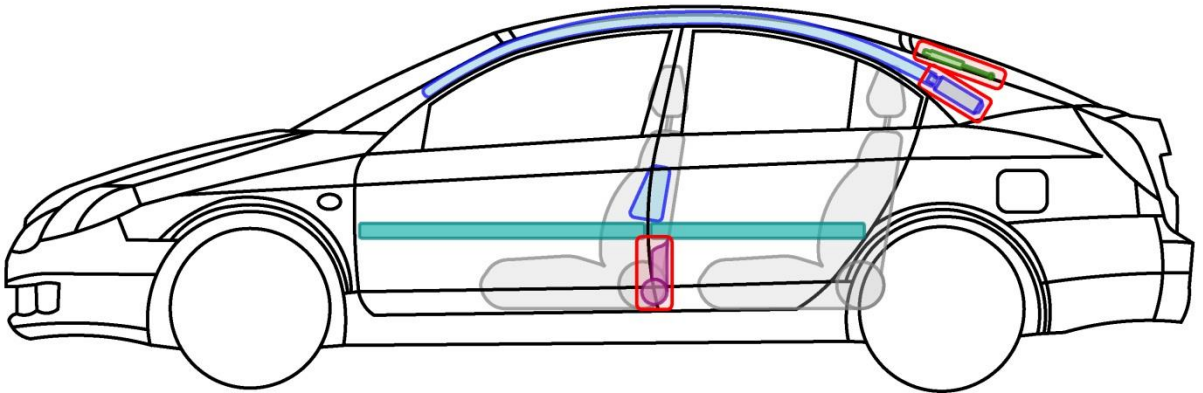
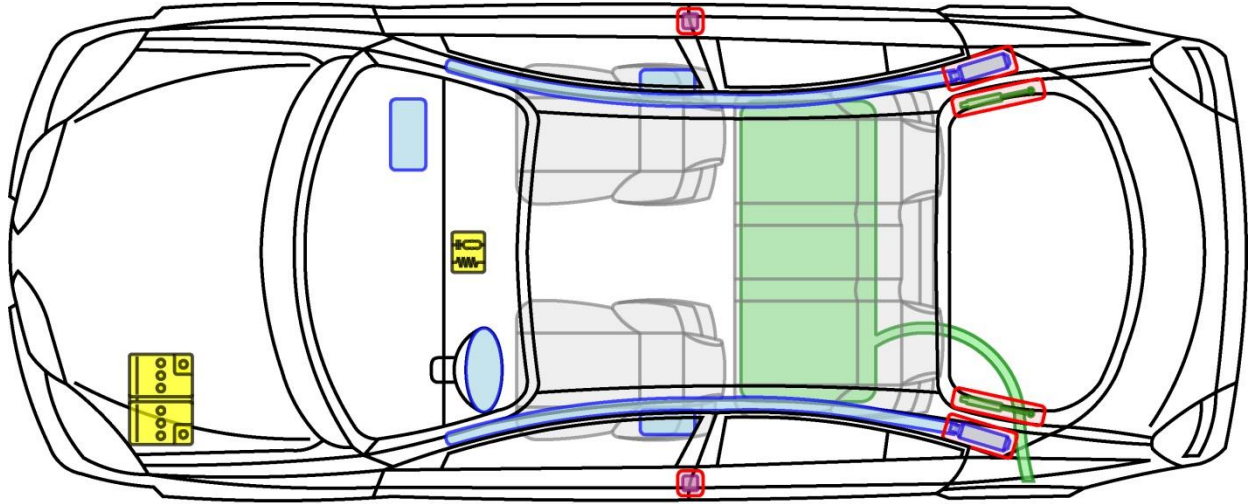

# PRIMERA 5-Türer

Typ: P12, 2002-2008

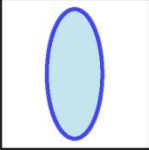

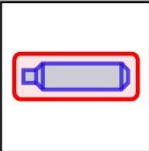
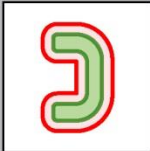
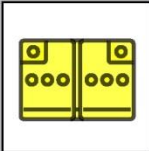
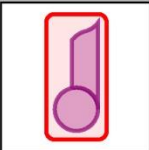
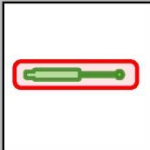
## Legende

	Airbag		Karosserie- verstärkung		Steuergerät
	Gas- generator		Überroll- schutz		Batterie
	Gurt- straffer		Gasdruck- dämpfer		Kraftstoff- tank

PRIMERA



# PRIMERA Kombi

Typ: P12, 2002-2008

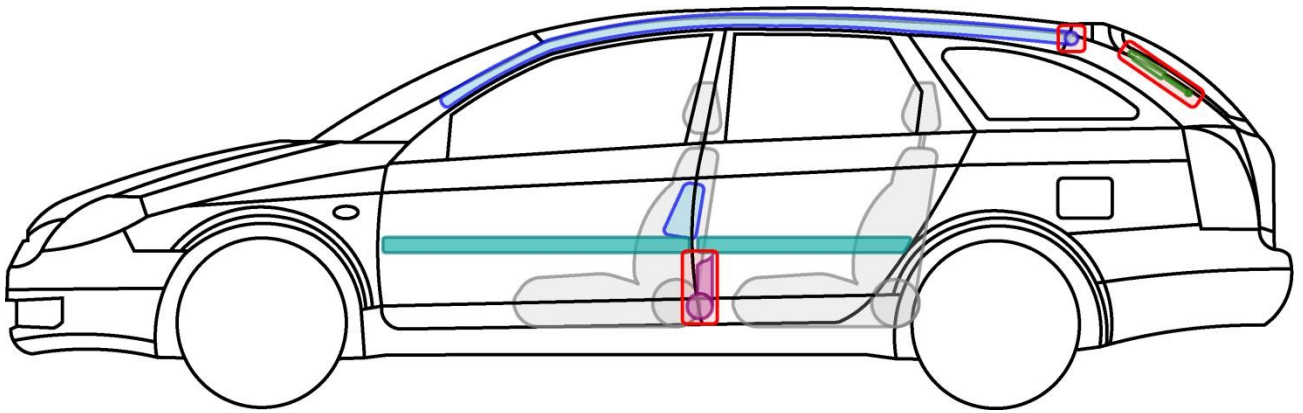
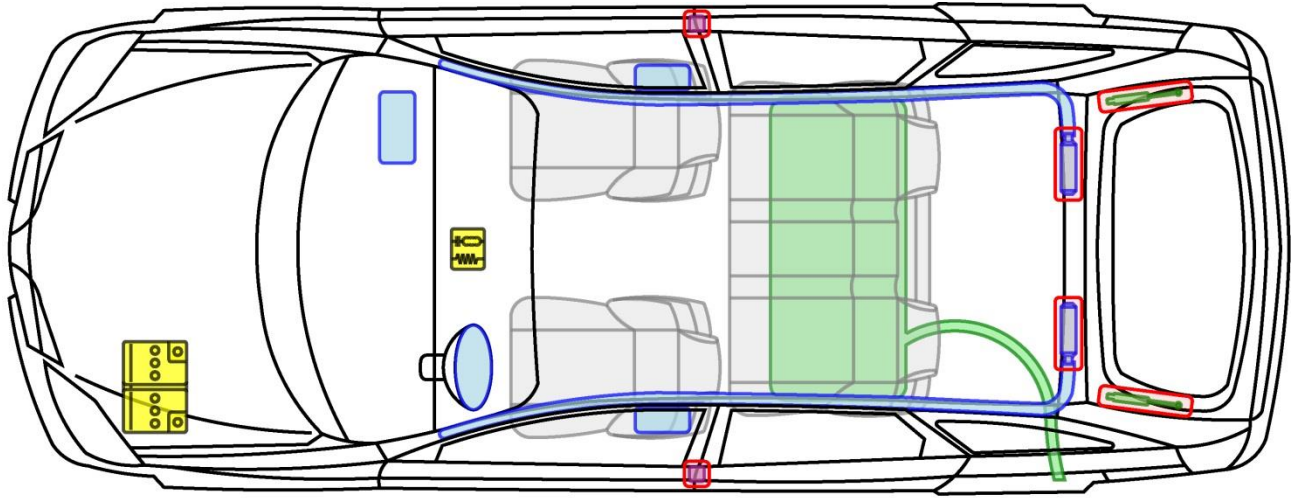

## Legende

	Airbag		Karosserie- verstärkung		Steuergerät
	Gas- generator		Überroll- schutz		Batterie
	Gurt- straffer		Gasdruck- dämpfer		Kraftstoff- tank

PRIMERA







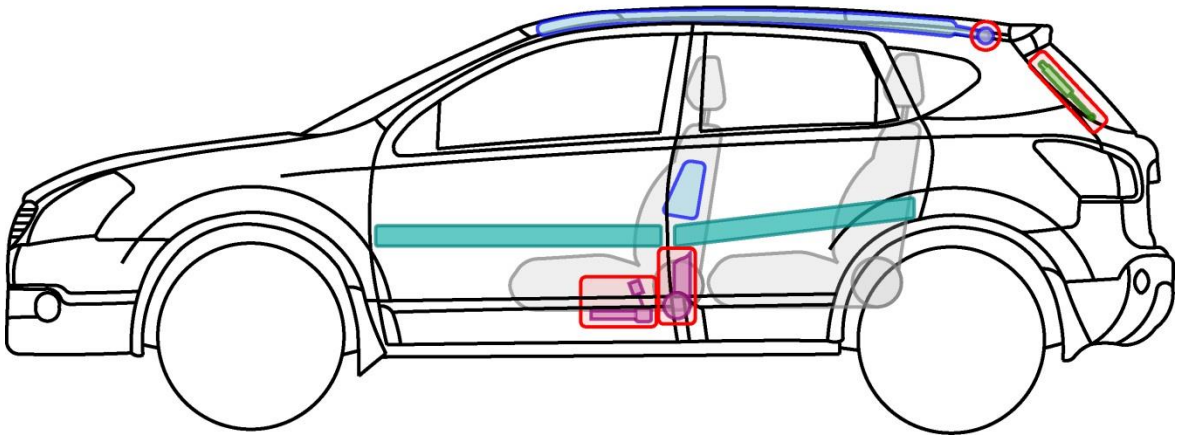
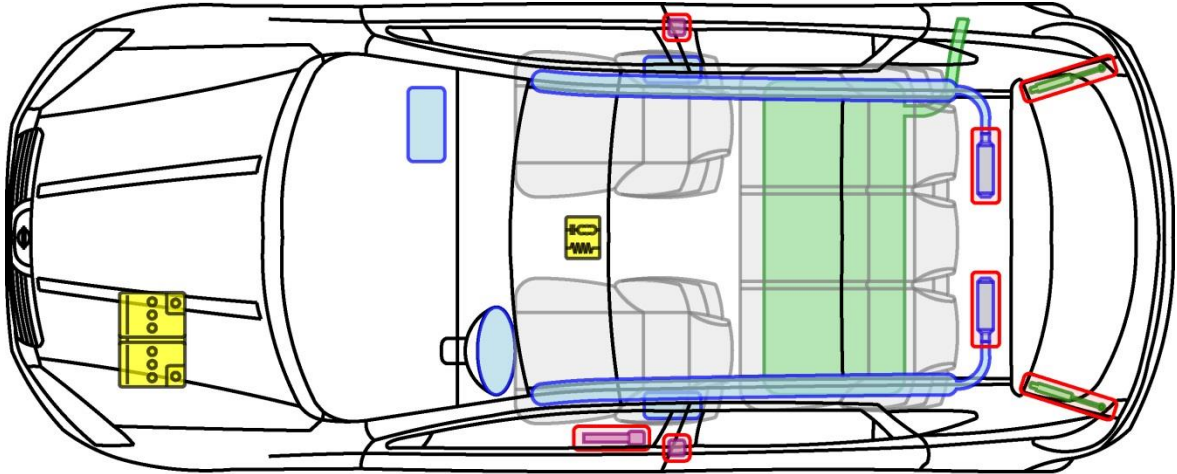

# QASHQAI

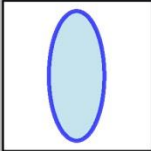
Typ: J11, 2007-2014

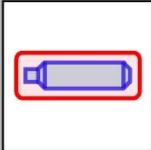

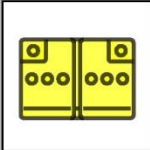
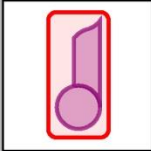
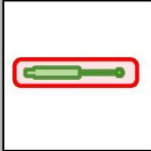
## Legende

	Airbag		Karosserie- verstärkung		Steuergerät
	Gas- generator		Überroll- schutz		Batterie
	Gurt- straffer		Gasdruck- dämpfer		Kraftstoff- tank

QASHQAI







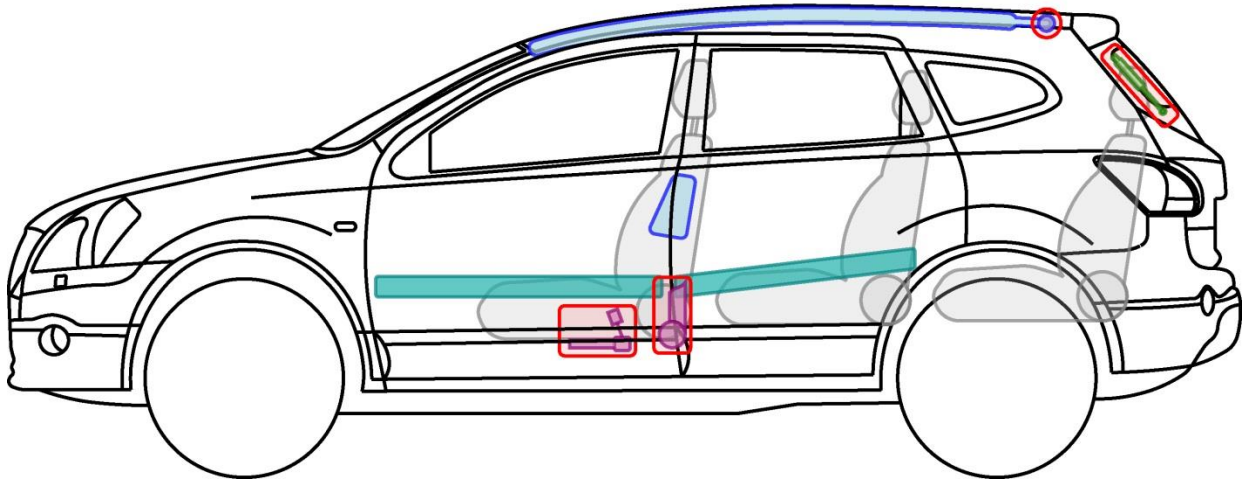
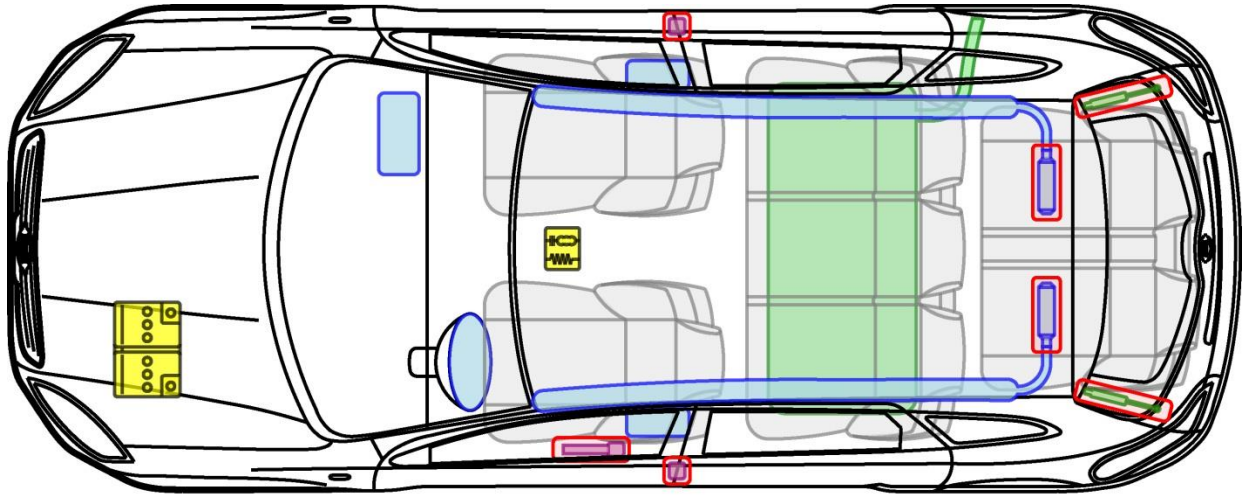

# QASHQAI+2

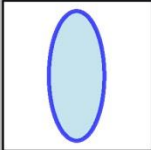
Typ: J10, 2008-2014

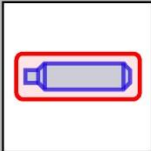

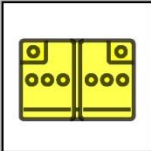
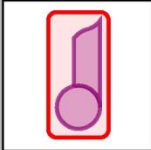
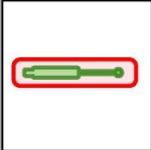
## Legende

	Airbag		Karosserie- verstärkung		Steuergerät
	Gas- generator		Überroll- schutz		Batterie
	Gurt- straffer		Gasdruck- dämpfer		Kraftstoff- tank

QASHQAI+2







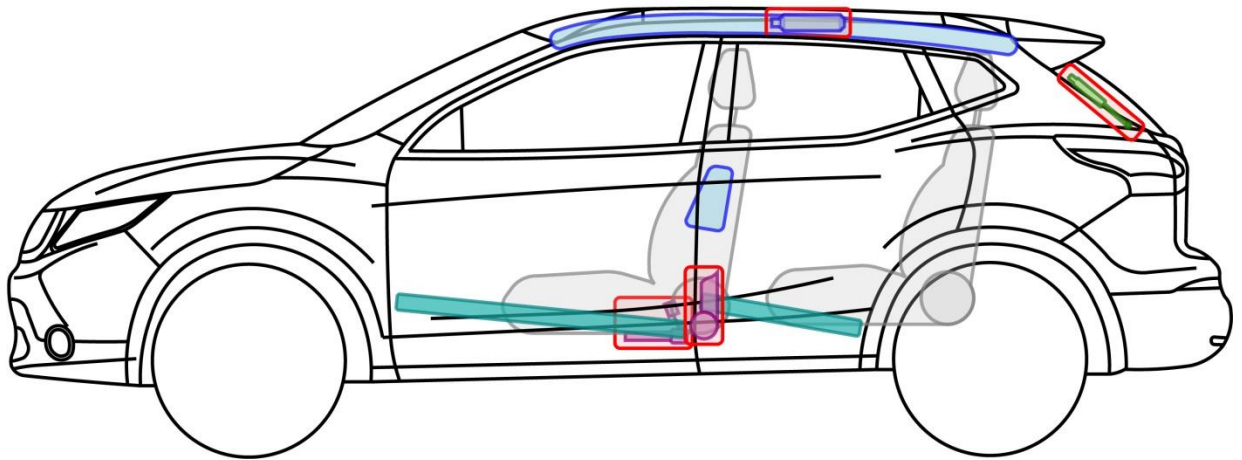
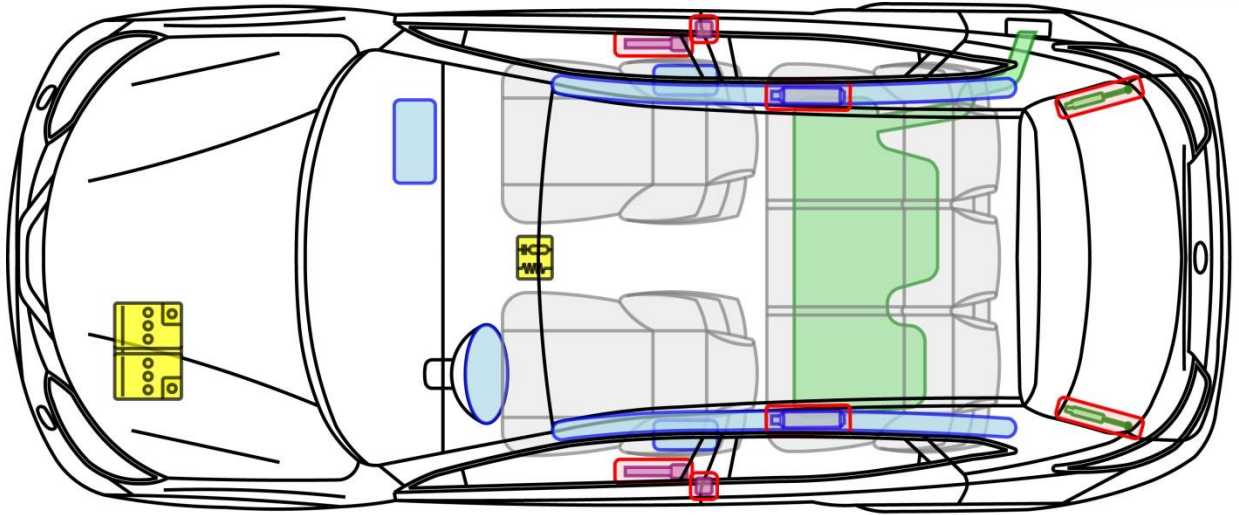

# QASHQAI

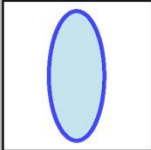
Typ: J11, 2014-

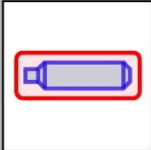

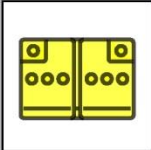
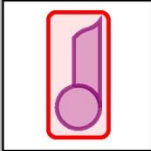
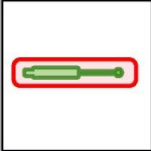
## Legende

	Airbag		Karosserie- verstärkung		Steuergerät
	Gas- generator		Überroll- schutz		Batterie
	Gurt- straffer		Gasdruck- dämpfer		Kraftstoff- tank

**QASHQAI**



# TIIDA

Typ: C11, 2006-

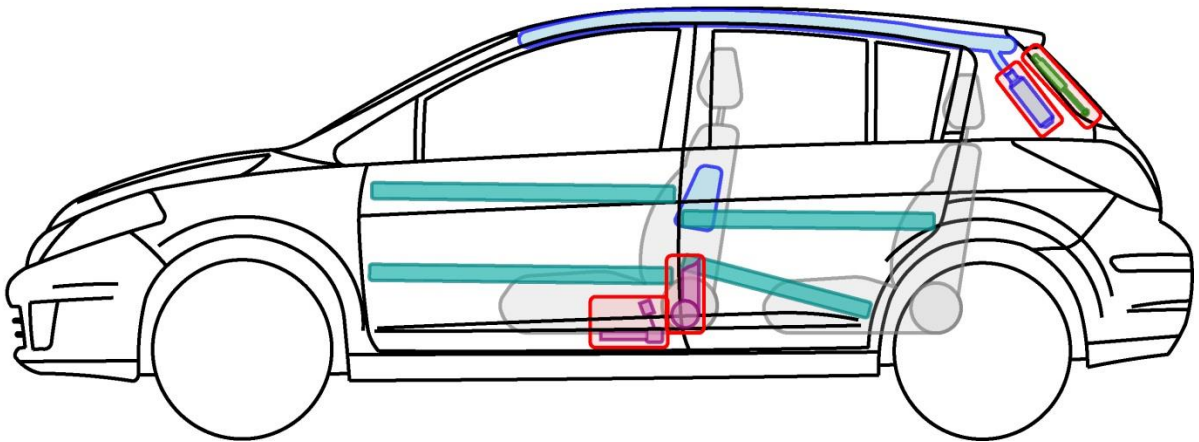
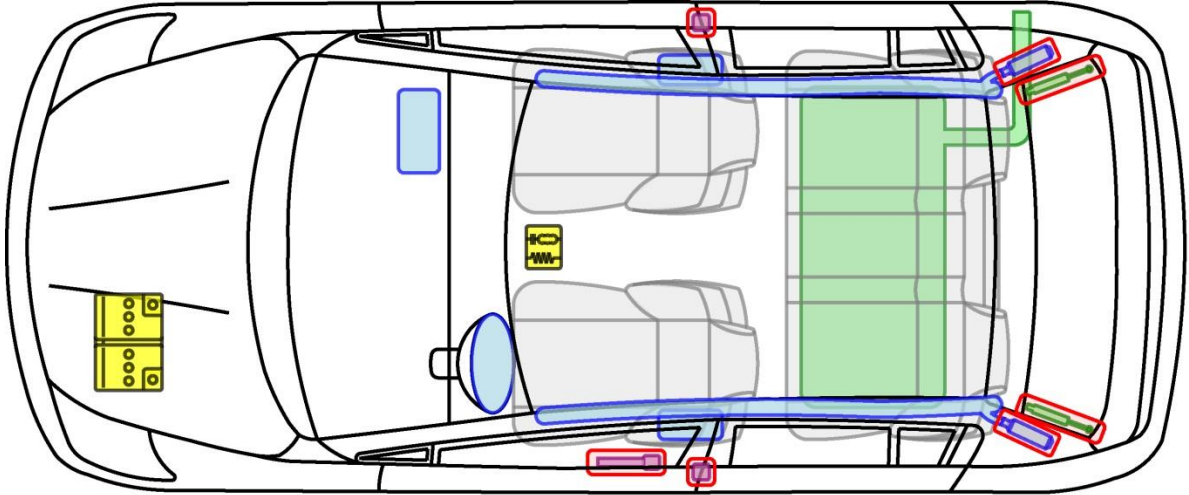

### Legende

	Airbag		Karosserie- verstärkung		Steuergerät
	Gas- generator		Überroll- schutz		Batterie
	Gurt- straffer		Gasdruck- dämpfer		Kraftstoff- tank

TIIDA







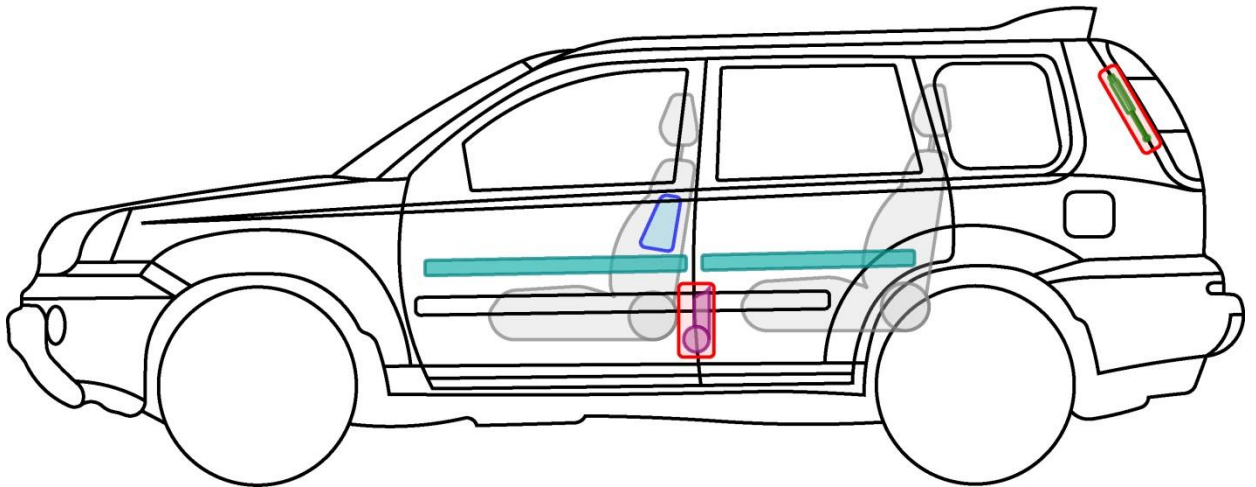
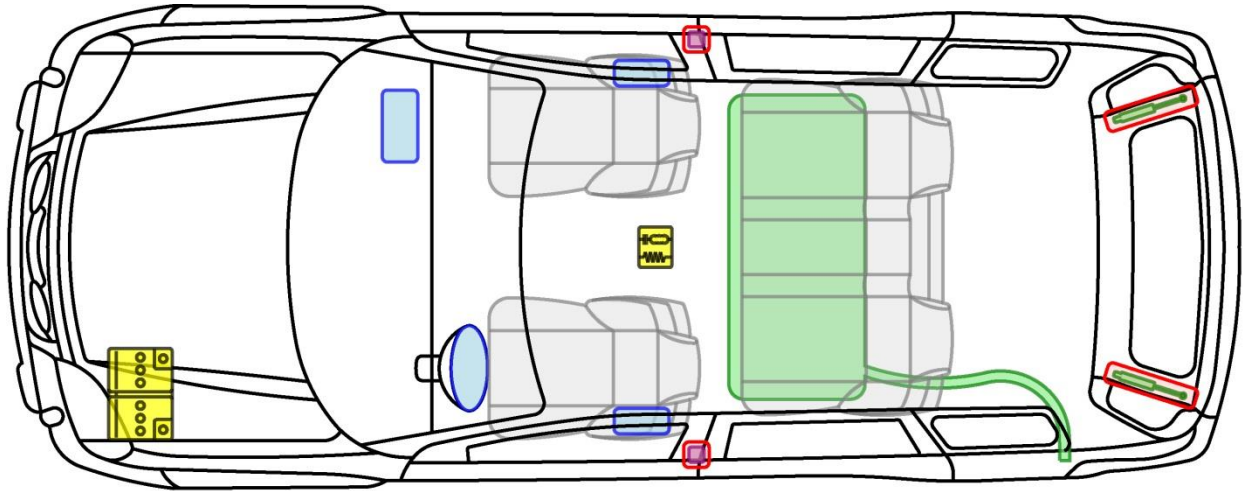

# X-TRAIL

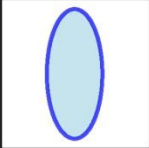
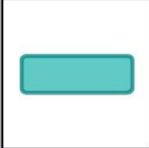
Typ: T30, 2001-2007

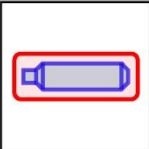

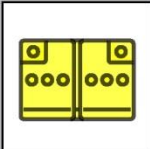
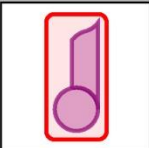
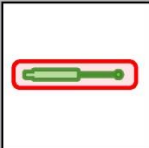
## Legende

	Airbag		Karosserie- verstärkung		Steuergerät
	Gas- generator		Überroll- schutz		Batterie
	Gurt- straffer		Gasdruck- dämpfer		Kraftstoff- tank

X-TRAIL





# X-TRAIL

Typ: T31, 2007-

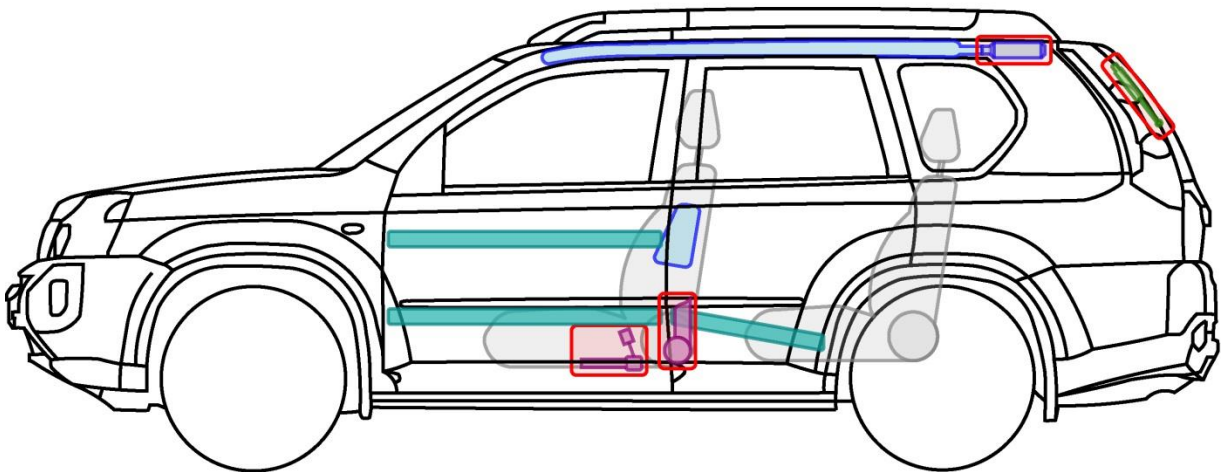
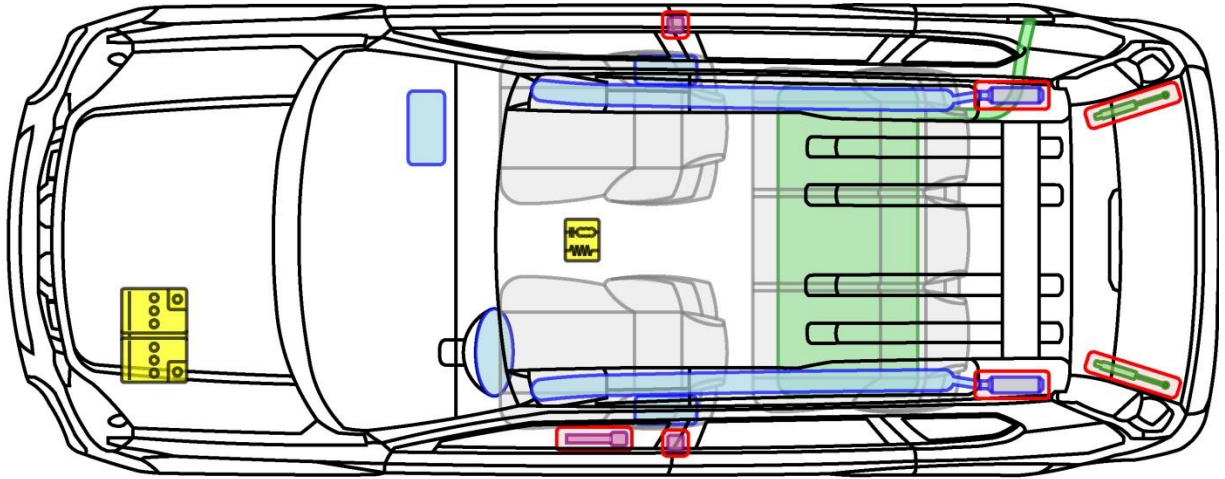

## Legende

	Airbag		Karosserie- verstärkung		Steuergerät
	Gas- generator		Überroll- schutz		Batterie
	Gurt- straffer		Gasdruck- dämpfer		Kraftstoff- tank

X-TRAIL